



TECHNICAL CATALOG 2026



ARFIT, THE GLOBAL HVAC SOLUTION

A single partner offering a wide range of products and expertise, translating them into the ideal comprehensive solution for your HVAC project.

Here you will find—from the most demanding technical specifications to the highest hygiene standards—a customized solution for every project: The Universal HVAC Solution.

We are a team of trained and dedicated professionals, ensuring the continuous improvement of the products we sell and the projects we develop.

We are committed to constant growth, driven by the synergy among our employees, customers, partners, and suppliers.



MISSION

- To be a leading partner in providing climate control equipment and services;
- To ensure customer satisfaction and exceed their expectations;
- To promote continuous improvement.

VISION

- To be a company of choice;
- To focus on service excellence and human resource development;
- To collaborate with partners, clients, and suppliers.

VALUES

- Conduct our activities with integrity, serenity, and transparency;
- Value people as a way to value the company, focusing on the training, development, and motivation of human resources;
- Achieve results and find solutions with responsibility, determination, and professionalism;
- Ensure satisfaction of applicable requirements and continuous improvement of developed processes;
- Promote the competence and excellence of our performance, winning and retaining clients.



COMMITMENT IS IN OUR DNA

Since January 9, 2008, we have been committed to steady growth, supported by a team of experts working in collaboration with customers, partners, and suppliers.

Today we offer Arfit, the Comprehensive HVAC Solution.

A tailor-made solution for every industry!



Hospitals



Educational
Centers



Shopping
Centers



Industry



Hotels



Basements
and Cellars



Pharmaceutical
Laboratories



Offices

BE PART OF THE SOLUTION

This is the philosophy that drives the day-to-day work of a team committed to excellence in order to provide the market with integrated solutions tailored to each project.

To speak of our history is to speak of skilled and dedicated employees who ensure the continuous improvement of the products we offer and the projects we develop.





ARFITPRO SELECTION PROGRAM

It all starts with the selection software for each air handling unit.

Every parameter, technical specification, and detail takes shape through ArfitPro, enabling a suitable, versatile, and intuitive configuration that meets all the needs and specific requirements of each project.

It's all about flexibility and versatility through a selection program.

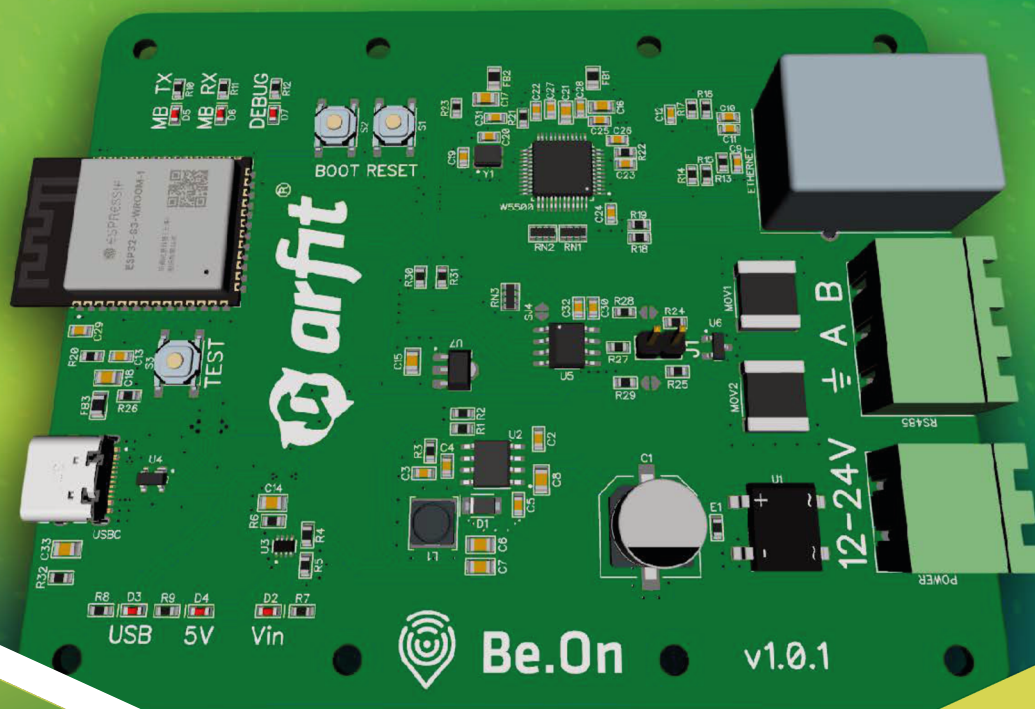

BE.ON BE.SMART - STAY TWO STEPS AHEAD

REMOTE MONITORING OF INSTALLED EQUIPMENT

The Be.On. Be.Smart solution integrates directly with Arfit equipment through the installation of a physical module—Be.On—on the equipment, enabling the collection, transmission, and analysis of operational data in real time. The connection to the cloud is made via Wi-Fi or Ethernet cable.

In turn, the Be.Smart digital platform centralizes equipment information, enabling monitoring of operational status, access to performance reports, remote configuration of parameters, and the sending of automatic maintenance alerts.

4 TECHNICAL PILLARS:

- > Direct integration and flexible connectivity;
- > Continuous monitoring with automatic alerts;
- > Intelligent data analysis and regular reports;
- > Centralized management with access control and remote configuration.



R&D

We promote innovation, research, and development in various fields, such as design, materials, thermodynamics, automation, and control, creating and refining products and solutions to meet market needs.

We work in interdisciplinary teams to integrate diverse knowledge and perspectives, and we monitor industry trends to identify opportunities for innovation and new product development.

We test and validate each prototype to ensure it meets performance, safety, and regulatory requirements.

In short, we play a crucial role in driving innovation and developing solutions for every challenge, no matter how complex, while always prioritizing efficiency and sustainability.

THE PRODUCTION LINE

It is in the factory that each product comes to life, transforming an idea and concept into something tangible and ready for use.

The factory is the heart of production, where we apply engineering knowledge, technology, and human talent to transform raw materials into Arfit Products.

Today, we have a production area of 4800m², a complete Manufacturer ERP system, and quality standards compliant with the most demanding certifications.





ARFIT QUALITY

A fundamental area that ensures our products exceed customer expectations in terms of quality, reliability, and compliance with established standards.

This is where we promote continuous improvement of processes and products, from product development to delivery to the customer



SUPPORT AND MAINTENANCE

A personalized service of predictive, preventive, and corrective maintenance, carried out by specialized technicians nationwide, ensuring the upkeep of your investment and guaranteeing the durability and proper preservation of equipment in the medium and long term.

For us, it is essential to maintain the proper functioning of all products and their components, ensuring that performance endures over time.

CERTIFICATIONS

With each certification we present, we ensure the consistency of our products and services, guaranteeing that each product meets specific standards of quality, safety, performance, and regulatory compliance.

Through each certification, we demonstrate our commitment to quality and ensure that all processes adhere to established standards and our commitment to social and environmental responsibility.

We meet the most demanding certifications, both in terms of processes and products.



VENTILATION



Axial fan
VA
VAD
VAJ

Pág. 15



ABS inline fan
EVO LINE A 2 EC
EVO LINE A 2 AC

Pág. 21



Metal inline fan
EVO LINE M EC
EVO LINE M AC

Pág. 25



ABS Silent inline fan
EVO LINE SILENT A 2 EC
EVO LINE SILENT A 2 AC

Pág. 30



Silent inline fan
EVO LINE SILENT M EC
EVO LINE SILENT M AC

Pág. 34



Low-profile ventilation units
EVO LINE BOX LP EC
EVO LINE BOX LP AC

Pág. 38



Ventilation Box EC
EVO BOX EC

Pág. 43



Ventilation Box EC
PLUG EC

Pág. 46



Ventilation Box AC
DA IN

Pág. 49



Solar dissipator
SOLAR

Pág. 53



Electric heaters
EVO REEL

Pág. 55

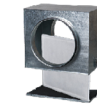

Filtration module
CFG4
CFF7

Pág. 58

HEAT RECOVERY



Single-flow heat recovery unit
VMC 2 C 30C|60C

Pág. 63



Horizontal double-flow heat recovery unit
VMC H

Pág. 65



Vertical double-flow heat recovery unit
VMC V

Pág. 70



Horizontal double-flow heat recovery unit
VMC2

Pág. 72

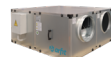

Heat recovery unit
EVOEVO 2 EC
EVOEVO 2 AC

Pág. 80



Heat recovery unit
EVOEVO 3 SLIM
EVOEVO 3

Pág. 106



Heat recovery unit
EVOEVO 2 PLUS

Pág. 139

DEHUMIDIFICATION



Domestic dehumidifier
DDS - DCS - DVS - DOS | CCV -
CCA - CCW

Pág. 156



Industrial/swimming pool dehumidifier
ID-SP | IT-ST

Pág. 166



Industrial dehumidifier/recovery tank
SPR | STR

Pág. 170

AIR TREATMENT

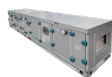

Air Treatment / Handling Units
PURE P
PURE H

Pág. 176

AIR CONDITIONING / HANDLING UNITS



Low-profile unit
UBP EC
UBP AC
UBP PLUS EC
UBP PLUS AC

Pág. 180



Air handling units
ECOAIR 2 SLIM
ECOAIR 2

Pág. 204

AIR CONDITIONING UNIT



Condensing unit
HIGH EF PLUS

Pág. 226

CONTROL



Digital Control
CM3D

Pág. 232



VMC2 Control
CM2D

Pág. 234



VMC Control
CM4B

Pág. 235



Industrial Control
Smart
Smart Evolution
SMART PRO 2

Pág. 236



BMS SOLUTIONS
SMART VISION 5
SMART SERVER
SMART EYES

Pág. 242

ACCESSORIES



Accessories for Product Range

Pág. 247

VMC Installation Accessories

Pág. 250

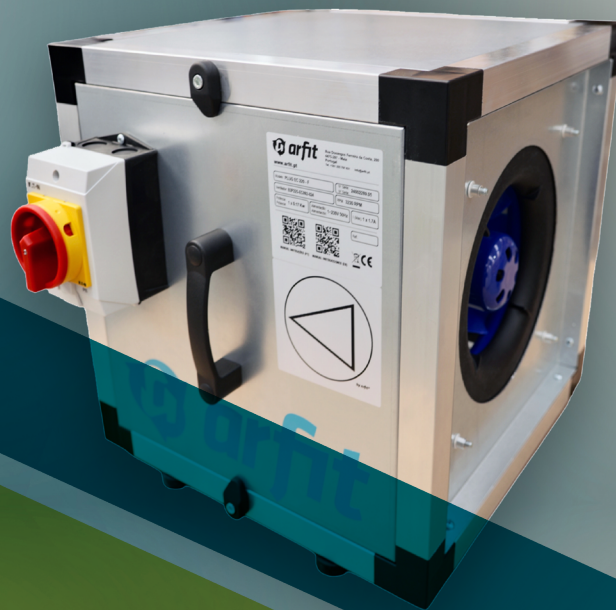

VENTILATION





Axial fan



Silent

DESCRIPTION

Axial fan, VA model with an elegant design.

Structure and impeller made of high-resistance ABS. Protection class IP34 and airflow up to 274 m³/h.

Available in 3 sizes, standard version or version with timer.

Single-phase motor.

STANDARDS AND CERTIFICATIONS



ADVANTAGES

- Elegant design.
- High resistance.

ACCESSORIES

- On - Off switch

CHARACTERISTICS

VA	100	120	150
Airflow (m ³ /h)	124	219	280
Power (kW)	0,016	0,024	0,025
Power Supply (V F Hz)	230 1 50	230 1 50	230 1 50
Motor IP Class	IP 34	IP 34	IP 34
Sound Pressure (dB (A)) *	37	37	34

* Sound Pressure level at 3 m

PERFORMANCE CURVES

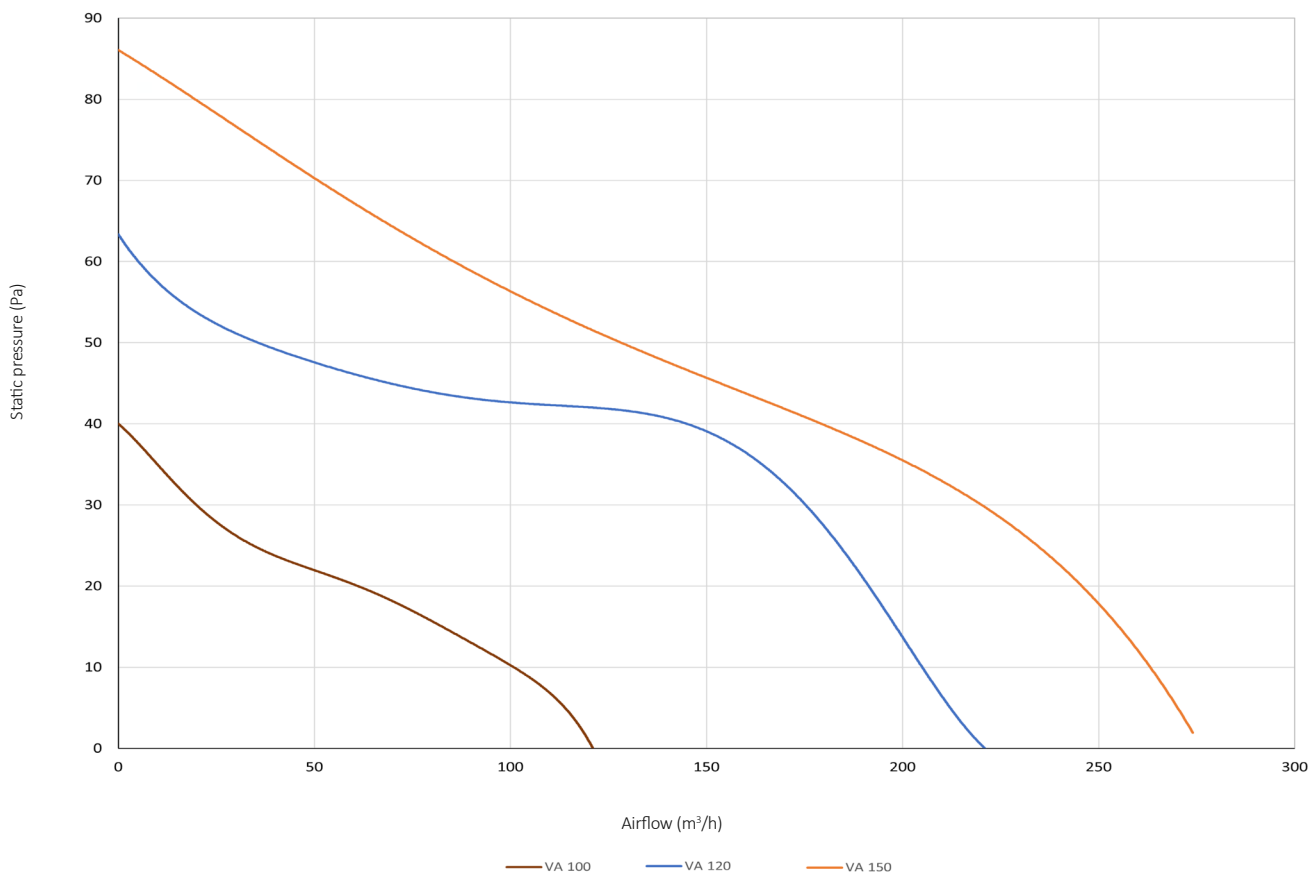

DIMENSIONS

VA	100	120	150
D (mm)	100	120	150
B (mm)	150	175	205
L (mm)	97	94	117
L1 (mm)	15	15	15

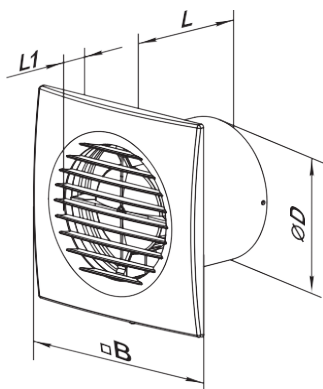



Axial Fan



Elegant Design

DESCRIPTION

Axial fan, VAD model with an elegant design.

Structure and impeller made of high-resistance plastic. Protection class IP44 and airflow up to 155 m³/h.

Available in 2 sizes, standard version or version with timer.

Single-phase motor.

STANDARDS AND CERTIFICATIONS



ADVANTAGES

- Elegant Design.
- High resistance.

ACCESSORIES

- On - Off switch

CHARACTERISTICS

VAD	100	125
Airflow (m ³ /h)	85	155
Power (kW)	0,008	0,018
Power Supply (V F Hz)	230 1 50	230 1 50
Motor IP Class	IP 44	IP 44
Sound Pressure (dB (A))*	27	32

* Sound Pressure Level at 3 m

PERFORMANCE CURVES

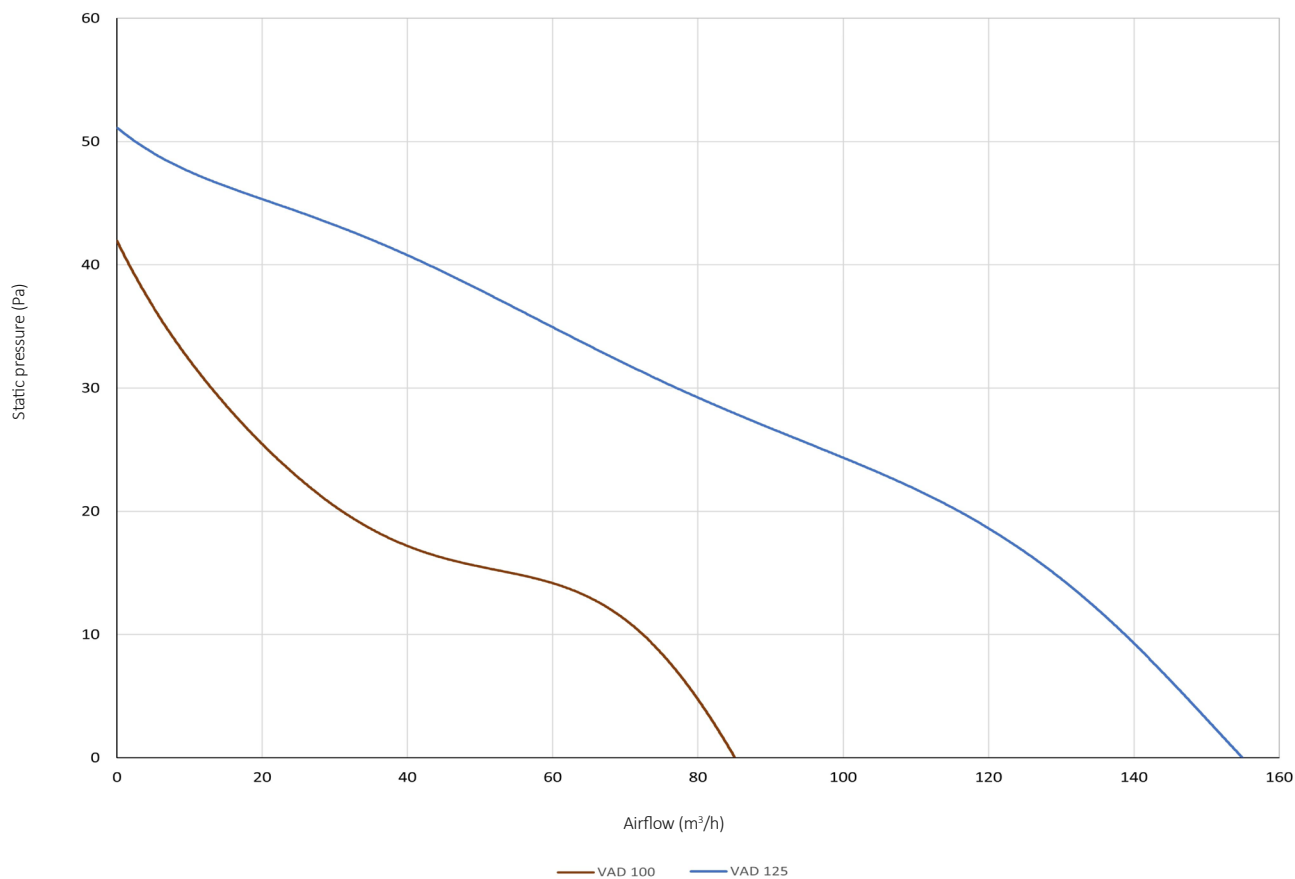

DIMENSIONS

VAD	100	125
D (mm)	99	123,5
B (mm)	160	180
L (mm)	79	85
L1 (mm)	38	38

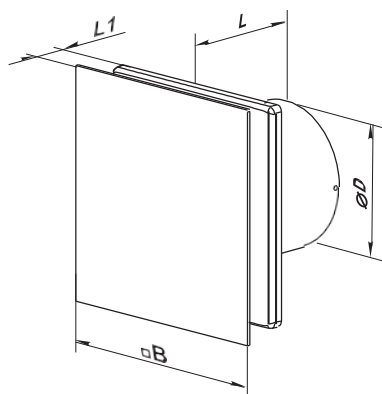



Axial Fan

DESCRIPTION

Axial fan, VAJ model with a modern design.

Structure and impeller made of high-resistance ABS. Equipped with automatic shutter. Protection class IPX4 and airflow up to 455 m³/h.

Single-phase motor.

STANDARDS AND CERTIFICATIONS



ADVANTAGES

- Modern design.
- High resistance.
- High airflow.
- Automatic shutter.

ACCESSORIES

- On - Off switch

CHARACTERISTICS

VAJ	230
Airflow (m ³ /h)	455
Power (kW)	0,029
Power Supply (V F Hz)	230 1 50
Motor IP Class	IPX4
Sound Pressure (dB (A))*	32
IMAX (A)	0,13

* Sound Pressure Level at 3 m



PERFORMANCE CURVES

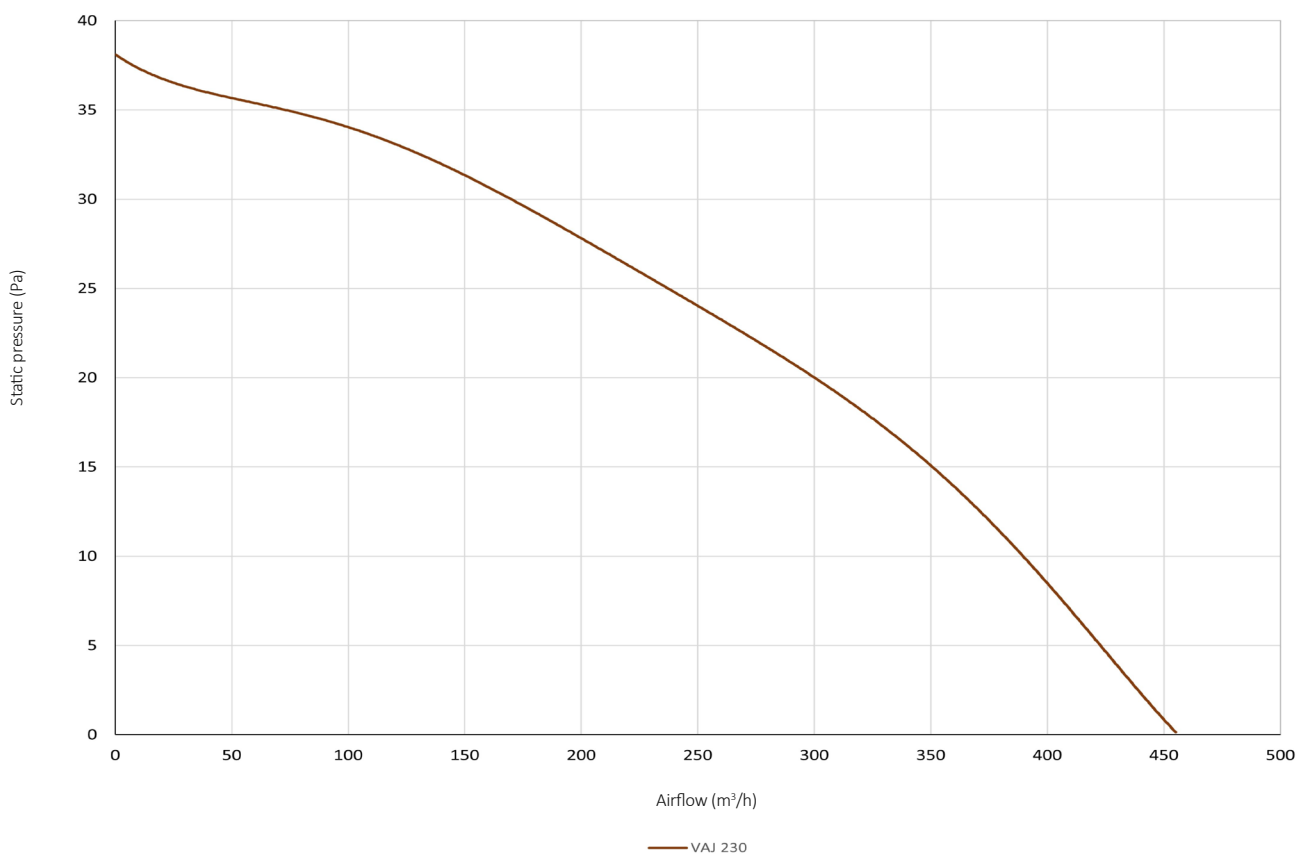

DIMENSIONS

VAJ	230
A (mm)	295
B (mm)	74
C (mm)	85
D (mm)	237

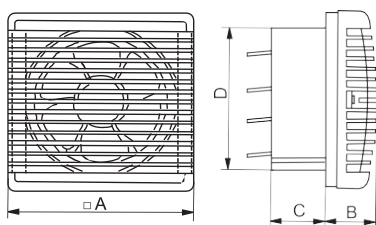

EVO LINE A 2 EC

[INDEX](#)

EC Technology



In Line Fan

DESCRIPTION

Inline fan, EVO LINE A 2 EC model for installation in circular ducts.

High-quality structure in low-flammability polypropylene. Central body removable by simple clip system for easy installation and maintenance. Aerodynamics specially designed for high performance and reduced noise levels. Allows installation in any position, in parallel or in series.

Available in 6 sizes.

ADVANTAGES

- Low-consumption electronically commutated EC motor.
- Easy installation and maintenance.
- Corrosion resistance.

ACCESSORIES

- Isolating switch
- 0-10 V airflow controller
- On - Off switch

COMPONENTS

MOTOR

Single-phase 230V - 50 Hz motor, latest generation EC electronically commutated DC motor with high efficiency, up to 90%. Optimized performance for any operating point. Control via a 0-10 V signal.

FAN

Mixed-flow fan with semi-spherical design and blades with innovative profile, ensuring exceptional airflow and pressure levels with reduced noise levels.

CHARACTERISTICS

EVO LINE A 2 EC	100	125	150	200	250	315
Airflow (m ³ /h)	366	561	647	1250	1650	2206
Motor Power (kW)	0,070	0,070	0,070	0,180	0,255	0,250
Maximum Rotational Speed (rpm)	3800	3800	3000	3000	3000	2350
Power Supply (V F Hz)	230 1 50					
IMAX (A)	0,47	0,47	0,47	1,05	1,5	1,4
Motor IP Class	IP44					
Motor Type (AC / EC)	EC					
ERP Compliance	Yes					
Sound Pressure (dB (A))*	48	52	60	64	70	66

* Sound Pressure Level at 3 m

PERFORMANCE CURVES

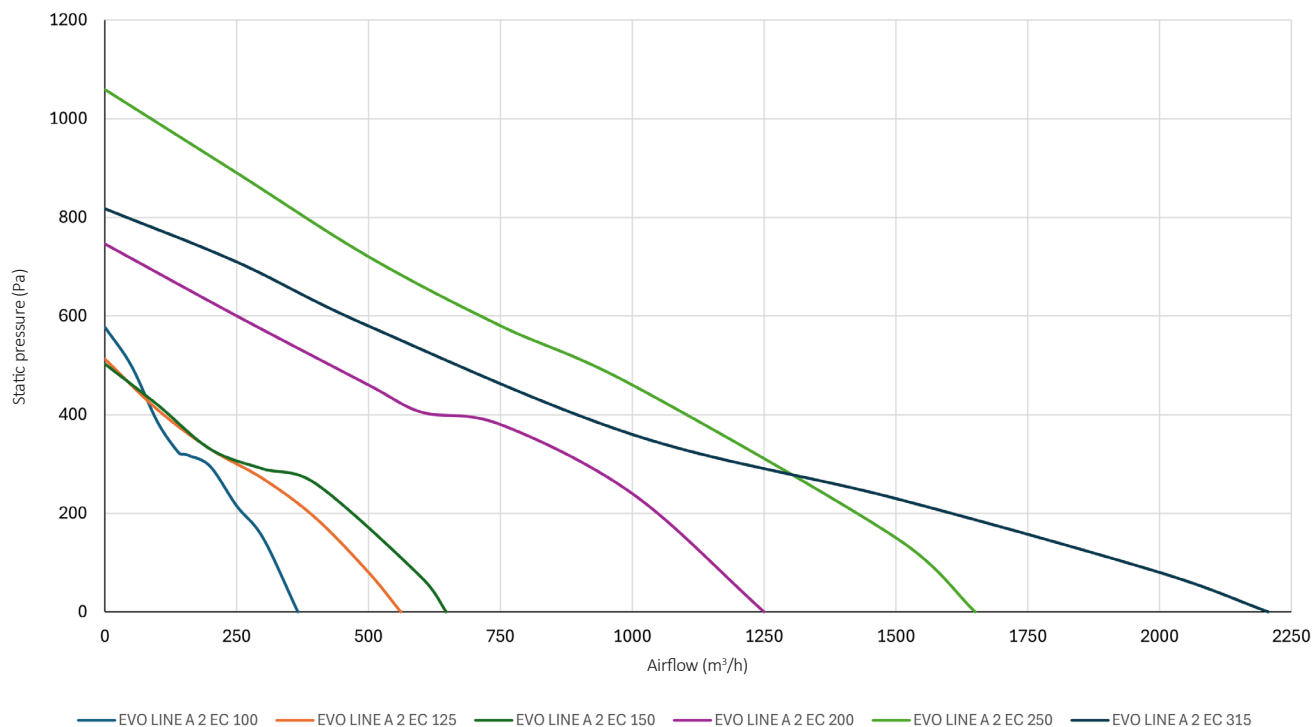

DIMENSIONS

EVO LINE A 2 EC	100	125	150	200	250	315
A (mm)	80	80	80	100	150	181
B (mm)	60	60	60	94	150	178
C (mm)	4,5	4,5	5	5,5	8*11	8*11
D (mm)	97	123	147	197	247	312
E (mm)	99	99	109	125	150	187
F (mm)	116	116	127	137	174	216
G (mm)	163	163	187	205	261	325
L (mm)	302	257	313	302	383	446
W (mm)	204	204	227	249	310	386
H (mm)	195	195	208	237	286	357
Weight (kg)	1,5	1,5	2,6	4,9	7,5	11

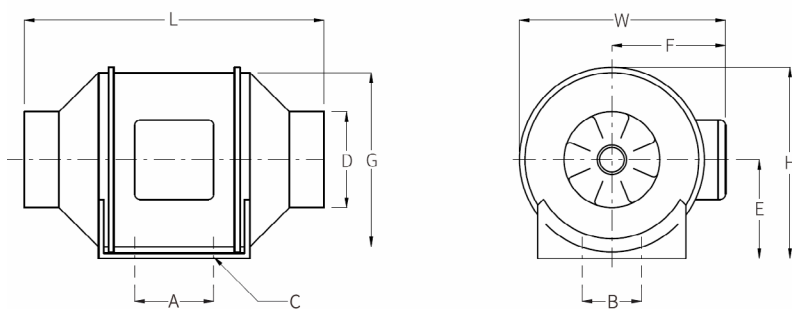

EVO LINE A 2 AC

INDEX



DESCRIPTION

Inline fan, EVO LINE A 2 AC model for installation in circular ducts.

High-quality structure in low-flammability polypropylene. Central body removable by simple clip system for easy installation and maintenance. Aerodynamics specially designed for high performance and reduced noise levels.

Allows installation in any position, in parallel or in series.

Available in 6 sizes.

ADVANTAGES

- Installation versatility.
- Easy installation and maintenance.
- Corrosion resistance.

ACCESSORIES

- Isolating switch
- On - Off switch
- Voltage regulator

COMPONENTS

MOTOR

Single-phase 230 V - 50 Hz low-consumption motor, 2 speeds with built-in thermal protection. Motor equipped with bearings, with a service life of 40.000 hours in continuous operation.

FAN

Mixed-flow fan with semi-spherical design and blades with innovative profile ensuring exceptional airflow and pressure levels with reduced noise levels.

CHARACTERISTICS

EVO LINE A 2 AC	100	125	150	200	250	315
Airflow (m ³ /h)	280 220	310 250	560 475	980 830	1700 1200	2900 2400
Power (kW)	0,06	0,06	0,07	0,10	0,13	0,23
Power Supply (V F Hz)	230 1 50					
IMAX (A)	0,2 0,174	0,2 0,174	0,31 0,264	0,42 0,409	0,812 0,65	1,33 1,10
Motor IP Class	IP44					
ERP Compliance	Yes					
Sound Pressure (dB(A)) *	30 25	32 27	35 30	50 45	60 54	66 61

* Sound Pressure Level at 3 m

PERFORMANCE CURVES

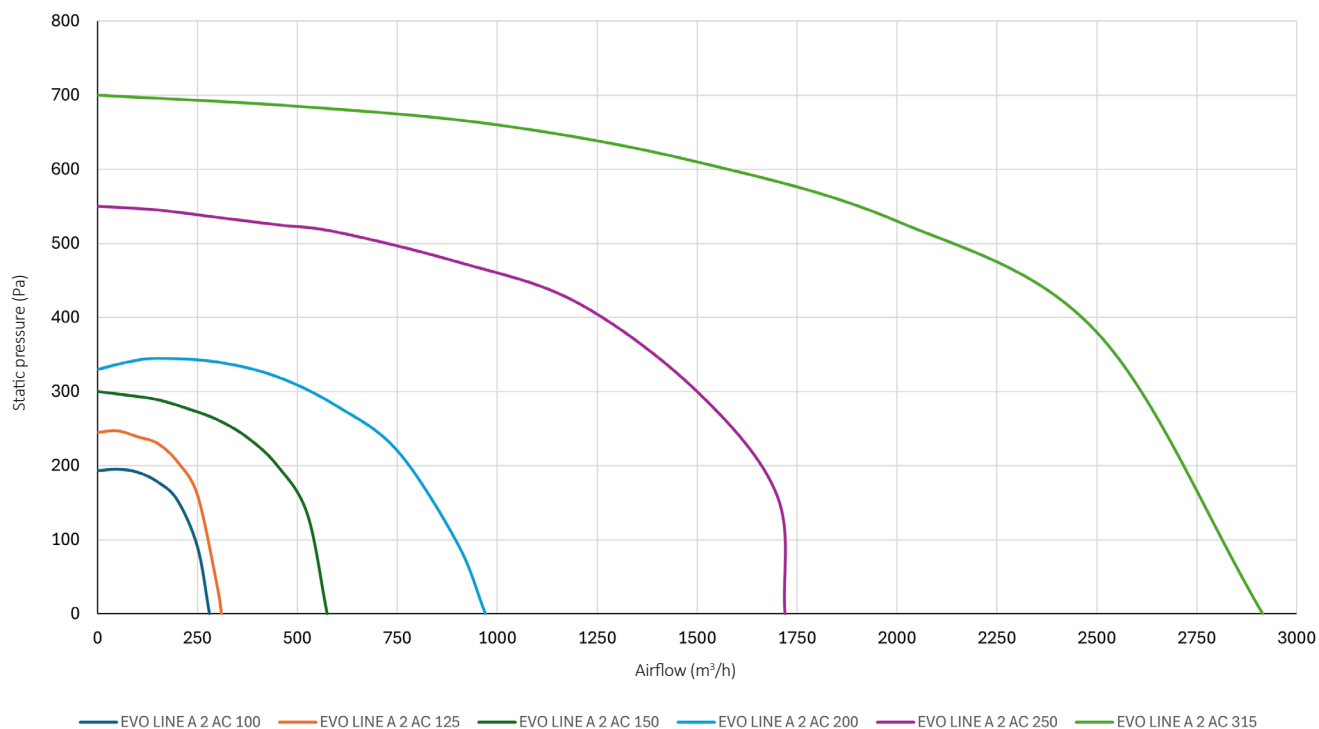

DIMENSIONS

EVO LINE A 2 AC	100	125	150	200	250	315
A (mm)	300	300	293	304	383	413
B (mm)	100	125	150	200	250	315
C (mm)	100	95	120	140	180	220
D (mm)	214	214	237	258	298	364
E (mm)	62	80	72	78	119	127
F (mm)	60	60	70	85	92	140
H (mm)	182	190	211	235	291	359
H1 (mm)	95	95	110	124	152	189
Weight (kg)	1,8	2,0	2,2	3,1	7,0	9,7

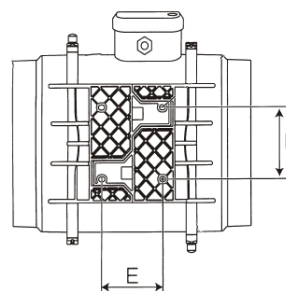
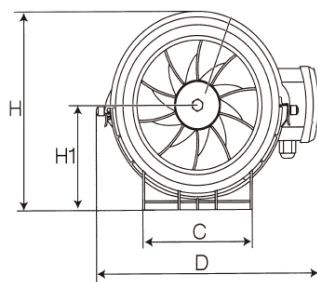
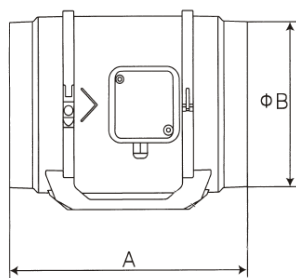

EVO LINE M EC

[INDEX](#)

DESCRIPTION

Inline fan, EVO LINE M EC model for installation in circular ducts.

Steel sheet structure with epoxy polyester coating, resistant to corrosion and mechanical damage, offering great installation versatility, as it operates in any position and can be connected to standard diameter circular ducts using simple clamps.

Available in 6 sizes.

ADVANTAGES

- Low-consumption electronically commutated EC motor.
- High robustness.

ACCESSORIES

- Isolating switch
- 0-10 V airflow controller
- On - Off switch

COMPONENTS

MOTOR

Single-phase 230 V - 50 Hz motor, latest generation EC electronically commutated DC motor with high efficiency, up to 90%. Optimized performance for any operating point. Control via a 0-10 V signal.

FAN

Single inlet centrifugal fan with backward-curved blades, balanced according to ISO1940 G2.5 and with vibration levels in accordance with AMCA 204.



CHARACTERISTICS

EVO LINE M EC	ø 100	ø 125	ø 150	ø 200	ø 250	ø 315
Airflow (m³/h)	345	480	620	845	1230	1820
Rotational Speed (rpm)	3600	3400	2800	2500	2900	2768
Motor Power (kW)	0,090	0,083	98	0,083	0,164	0,183
Motor IP Class	IP44					
Power Supply (V F Hz)	230 1 50					
IMAX (A)	0,7	0,58	0,73	0,63	1,15	1,44
Sound Pressure (dB (A))*	44	45	47	47	46	49

* Sound Pressure Level at 3 m

PERFORMANCE CURVES

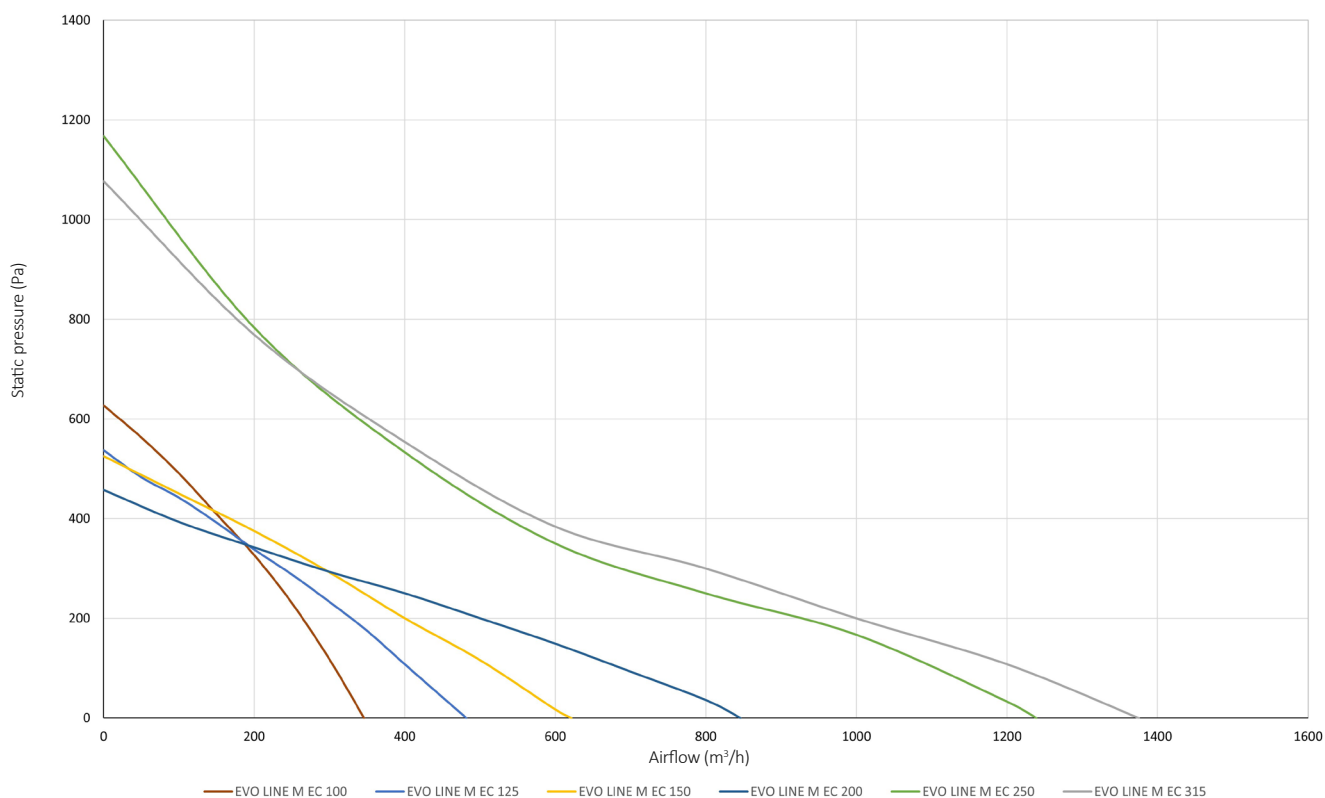

DIMENSIONS

EVO LINE M EC	ø 100	ø 125	ø 150	ø 200	ø 250	ø 315
D ø (mm)	98	123	149	198	248	313
D1 ø (mm)	255	255	305	345	345	410
H (mm)	340	340	365	435	435	420
B (mm)	310	310	360	395	395	505
B1 (mm)	270	270	320	355	355	475
L (mm)	203	203	220	245	250	440
L1 (mm)	20	20	25	25	25	60
L2 (mm)	25	25	25	30	30	60
Weight (kg)	3,2	3,2	4,9	5,1	5,1	9,4

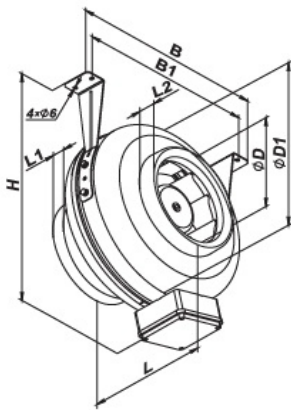

EVO LINE M AC

[INDEX](#)

In Line Fan

DESCRIPTION

Inline fan, EVO LINE M AC model for installation in circular ducts.

Steel sheet structure with galvanized steel finish, resistant to mechanical damage, offering great installation versatility, as it operates in any position and can be applied to standard diameter circular ducts using simple clamps.

Available in 6 sizes.

ADVANTAGES

- Installation versatility.
- High robustness.

ACCESSORIES

- Isolating switch
- Voltage regulator
- On - Off switch

COMPONENTS

MOTOR

Single-phase 230 V 50 Hz external rotor motor directly coupled, with built-in thermal protection, IP44, insulation class F.

FAN

Single inlet centrifugal fans with backward-curved blades, statically and dynamically balanced.

CHARACTERISTICS

EVO LINE M AC	ø 100	ø 125	ø 150	ø 200	ø 250	ø 315
Airflow (m ³ /h)	250	330	455	1000	1070	1540
Rotational Speed (rpm)	2812	2820	2780	2824	2765	2730
Motor Power (kW)	0,062	0,078	0,064	0,144	0,152	0,185
Motor IP Class	IP44					
IMAX (A)	0,28	0,34	0,29	0,63	0,66	0,81
Sound Pressure (dB (A))*	46	46	44	50	52	53

* Sound Pressure Level at 3 m

PERFORMANCE CURVES

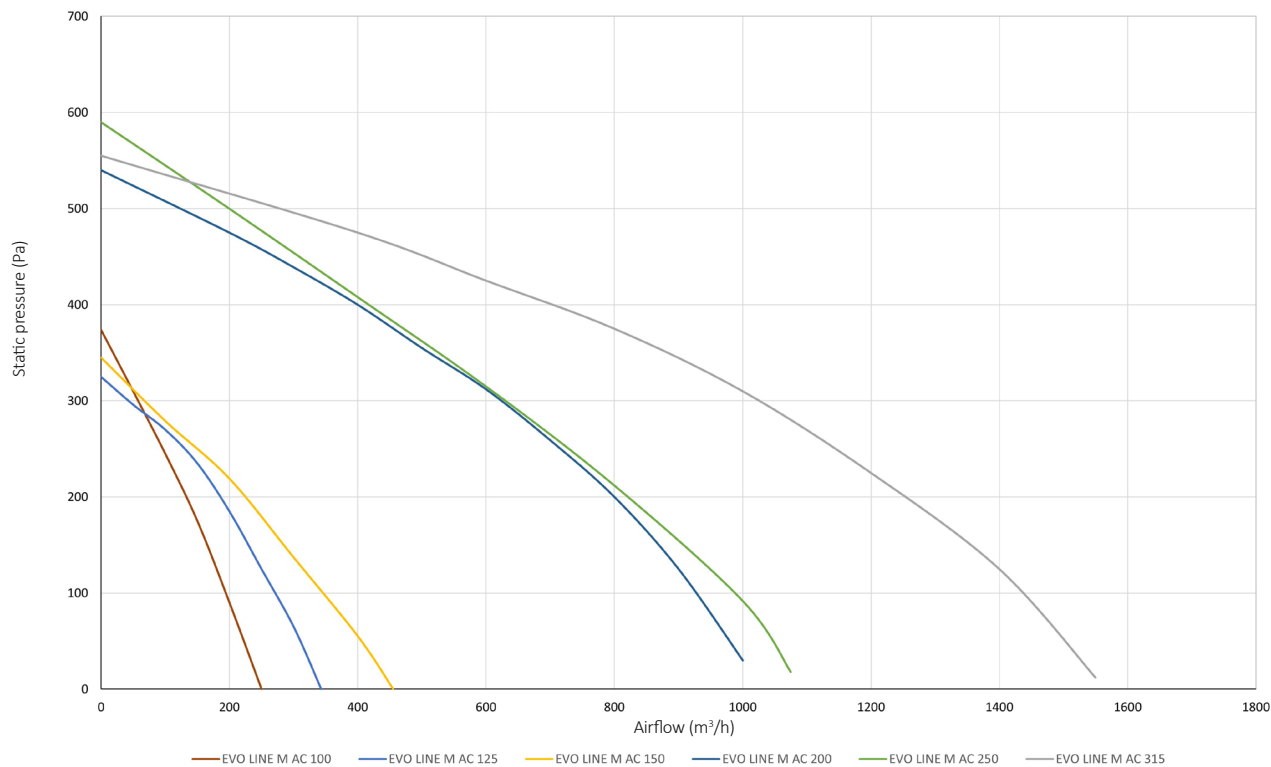

DIMENSIONS

EVO LINE M AC	ø 100	ø 125	ø 150	ø 200	ø 250	ø 315
D ø (mm)	98	123	149	198	249	313
D1 ø (mm)	237	237	274	332	332	402
B (mm)	253	253	290	340	340	410
B1 (mm)	293	293	330	380	380	450
L (mm)	202	202	170	245	213	308
L1 (mm)	23	23	20	25	25	33
L2 (mm)	22	22	20	29	29	55
L3 (mm)	30	30	30	40	40	40
Weight (kg)	2,8	2,9	4,8	5,6	5,1	6,5

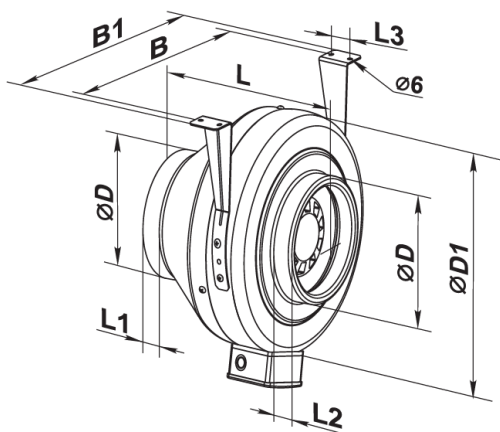



EVO LINE SILENT A 2 EC

INDEX



EC Technology



Acoustic Insulation



In Line Fan



Low Noise

DESCRIPTION

Inline silent fan, EVO LINE SILENT A 2 EC model with acoustic attenuation for installation in circular ducts.

External structure made of high-quality plastic with 50 mm non-flammable mineral wool acoustic insulation. The special perforation of the inner casing and the sound-absorbing material ensure sound attenuation across a wide frequency range.

Allows installation in any position, in parallel or in series.

Available in 3 sizes.

ADVANTAGES

- Low-consumption electronically commutated EC motor.
- Acoustic attenuation.
- Structure with 50 mm insulation.
- Corrosion resistance.

ACCESSORIES

- Isolating switch
- 0-10 V airflow control
- On - Off switch

COMPONENTS

MOTOR

Single-phase 230 V - 50 Hz motor, latest generation EC electronically commutated DC motor with high efficiency, up to 90%. Optimized performance for any operating point. Control via a 0-10 V signal.

FAN

Mixed-flow fan with semi-spherical design and blades with innovative profile ensuring exceptional airflow and pressure levels with reduced noise levels.

CHARACTERISTICS

EVO LINE SILENT A 2 EC	100 125	150	200
Airflow (m ³ /h)	560	602	1250
Motor Power (W)	73	70	180
Maximum Speed (rpm)	3800	3000	3000
Power Supply (V F Hz)	230 1 50		
IMAX (A)	0,52	0,47	1,05
Motor IP Class	IP44		
Motor Type (AC / EC)	EC		
ERP Compliance	Yes		
Sound Power (dB (A)) *	46	44	54

* Sound Power Level at 3 m

PERFORMANCE CURVES

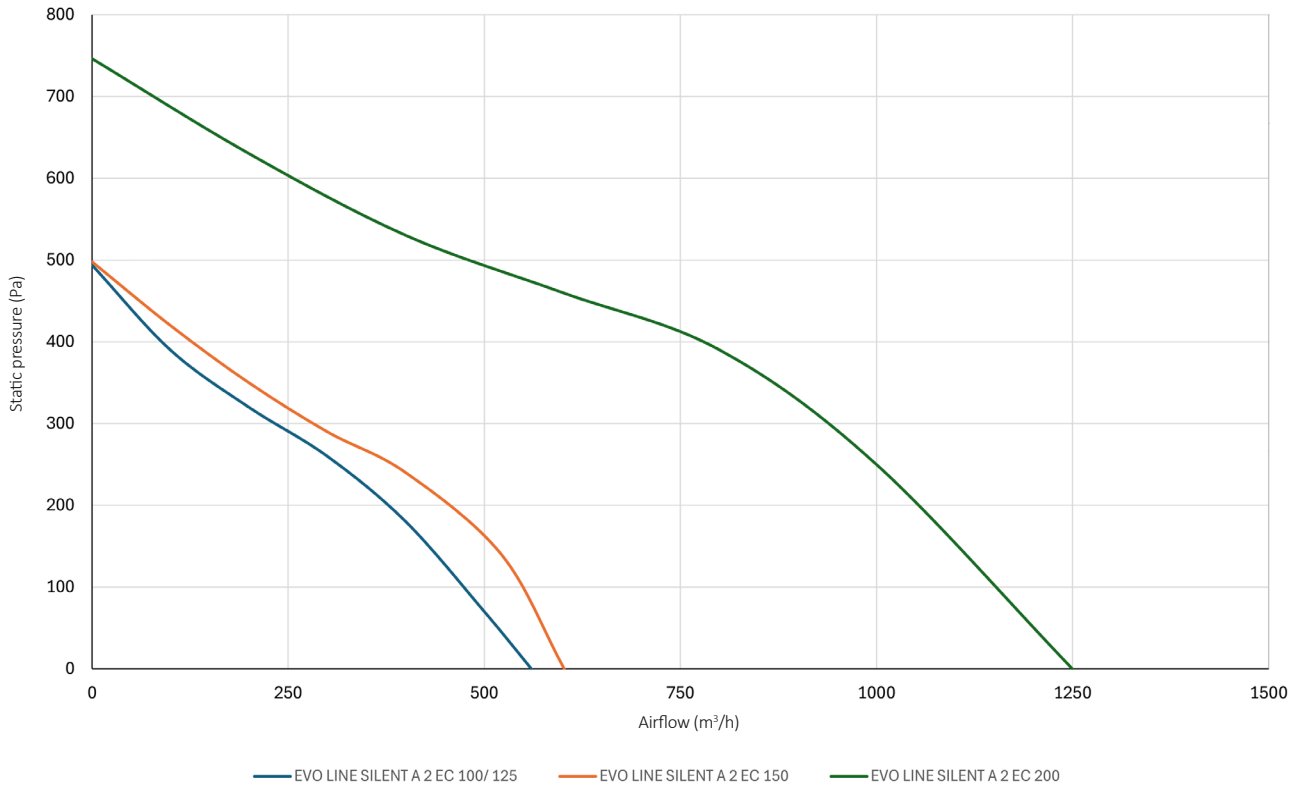

DIMENSIONS

EVO LINE SILENT A EC	100 125	150	200
A (mm)	248	251	339
B (mm)	82	95	128
C (mm)	5,5	5,3	5,6
D (mm)	97/123	149/158	198
E (mm)	330	352	436
L (mm)	580/462	488	567
W (mm)	205	221	262
H (mm)	225	244	301
Weight (kg)	2,8	4	5,9

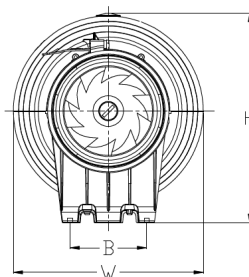
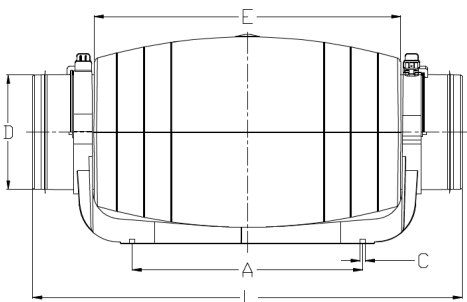



EVO LINE SILENT A 2 AC

INDEX



Acoustic Insulation



In Line Fan



High Efficiency Motor



Low Noise

DESCRIPTION

Inline silent fan, EVO LINE SILENT A 2 AC model with acoustic attenuation for installation in circular ducts.

External structure made of high-quality plastic with 50 mm non-flammable mineral wool acoustic insulation. The special perforation of the inner casing and the sound-absorbing material ensure sound attenuation across a wide frequency range.

Allows installation in any position, in parallel or in series.

Available in 4 sizes.

ADVANTAGES

- Acoustic attenuation.
- Structure with 50 mm insulation.
- Corrosion resistance.

ACCESSORIES

- Isolating switch
- On - Off switch
- Voltage regulator

COMPONENTS

MOTOR

Single-phase 230 V - 50 Hz low-consumption motor, 2 speeds with built-in thermal protection. Rotor and stator in stainless steel for increased durability.

FAN

Mixed-flow fan with semi-spherical design and blades with innovative profile ensuring exceptional airflow and pressure levels with reduced noise levels.

CHARACTERISTICS

EVO LINE SILENT A 2 AC	100	125	150	200
Airflow (m³/h) *	236 185	370 240	606 420	1042 770
Motor Power (W)	35	45	75	130
Maximum Speed (rpm)	2714 2050	2714 2051	2735 2010	2600 2100
Power Supply (V F Hz)	230 1 50			
IMAX (A)	0,16	0,2	0,34	0,59
Motor IP Class	IPX2			
Motor Type (AC / EC)	AC			
ERP Compliance	Yes			
Sound Pressure (dB (A)) **	30	30	40	50

* Airflow High Speed | Low Speed

** Sound pressure level at 3 m

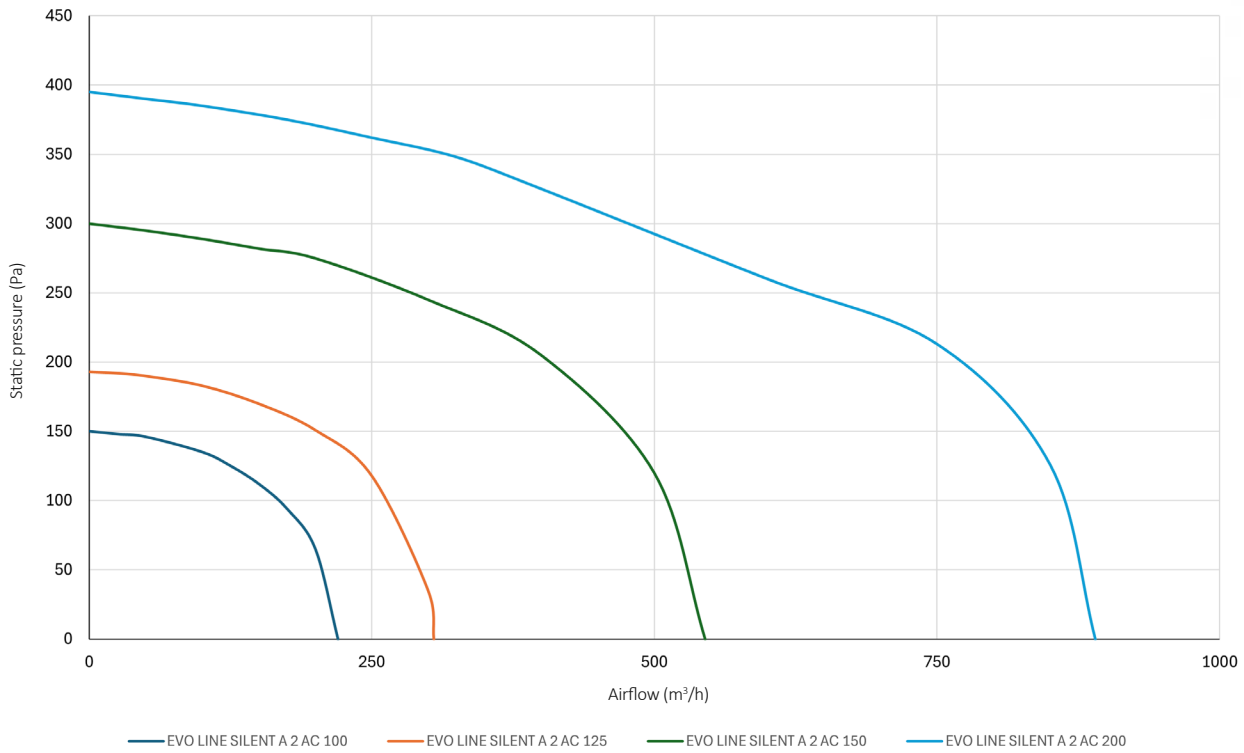
PERFORMANCE CURVES

DIMENSIONS

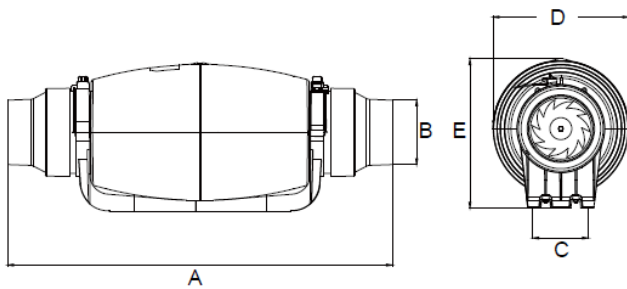
EVO LINE SILENT A 2 AC	100	125	150	200
A (mm)	450	450	490	565
B (mm)	96	120	147	194
C (mm)	98	98	116	148
D (mm)	205	205	223	265
E (mm)	220	220	243	297
Weight (kg)	3,2	3,2	4,3	6,3





EVO LINE SILENT M EC

INDEX



DESCRIPTION

Inline silent fan, EVO LINE SILENT M EC model with acoustic attenuation for installation in circular ducts.

Double-wall structure with 50 mm rock wool acoustic insulation, outer wall in steel sheet with epoxy polyester finish, inner wall with specially designed perforation for improved sound absorption.

Available in 5 sizes.



VENTILATION

ADVANTAGES

- Acoustic attenuation.
- 50 mm insulated panels.

ACCESSORIES

- Isolating switch
- 0-10 V airflow controller
- On - Off switch

COMPONENTS

MOTOR

Single-phase 230 V - 50 Hz motor, latest generation EC electronically commutated DC motor with high efficiency, up to 90%. Optimized performance for any operating point. Control via a 0-10 V signal.

FAN

EC duct fan, axial-flow impeller with semi-spherical design and blades with innovative profile ensuring exceptional airflow and pressure levels with reduced noise levels.

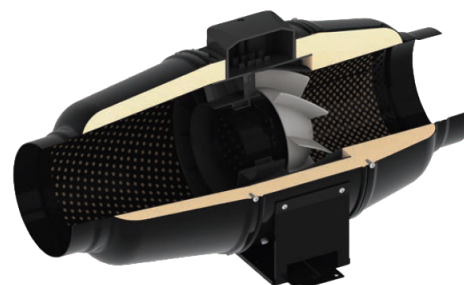

CHARACTERISTICS

EVO LINE SILENT M EC	ø 100	ø 150	ø 200	ø 250	ø 315
Airflow (m ³ /h)	300	600	1040	1285	1970
Rotational Speed (rpm)	3680	3750	3390	2870	2826
Motor Power (kW)	0,030	0,055	0,123	0,169	0,284
Motor IP Class	IPX4				
IMAX (A)	0,29	0,48	1,02	1,38	1,25
Sound Pressure (dB (A))*	37	38	43	43	46

* Sound Pressure Level at 3 m

PERFORMANCE CURVES

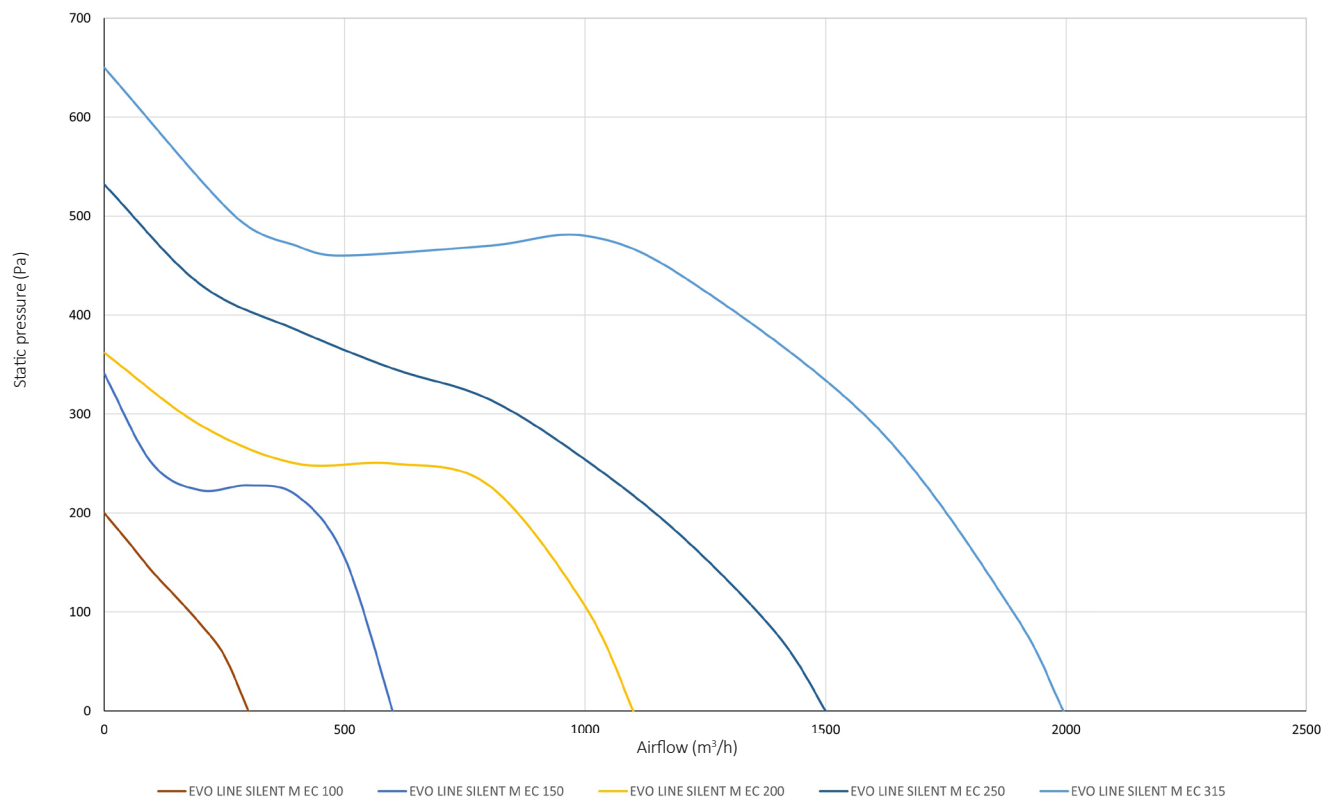

DIMENSIONS

EVO LINE SILENT M EC	ø 100	ø 150	ø 200	ø 250	ø 315
D ø (mm)	98	147	198	248	313
B (mm)	215	247	293	358	432
B1 (mm)	332	372	392	451	527
L (mm)	505	580	558	664	782
H (mm)	247	265	311	379	455
Weight (kg)	4,9	6	8,6	12,5	19,8

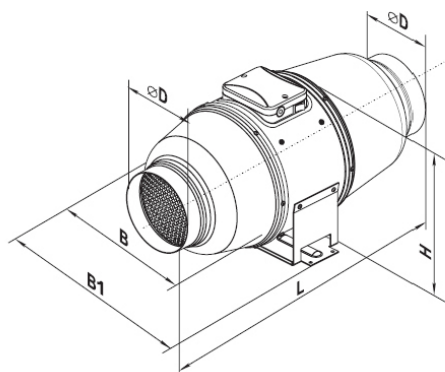



EVO LINE SILENT M AC

INDEX



DESCRIPTION

Inline silent fan, EVO LINE SILENT M AC model with acoustic attenuation for installation in circular ducts.

Double-wall structure with 50 mm rock wool acoustic insulation, outer wall in steel sheet with epoxy polyester finish, inner wall with specially designed perforation for improved sound absorption.

Available in 4 sizes.



Acoustic Insulation



In Line Fan

STANDARDS AND CERTIFICATIONS



ADVANTAGES

- Acoustic attenuation.
- 50 mm insulated panels.

ACCESSORIES

- Isolating switch
- Voltage regulator
- On - Off switch

COMPONENTS

MOTOR

Single-phase low-consumption two-speed motor. Equipped with thermal protection, IPX4 protection class.

FAN

Axial centrifugal fan with semi-spherical design and blades with innovative profile ensuring exceptional airflow and pressure levels with reduced noise levels.

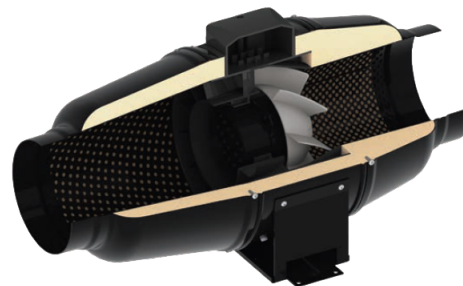

CHARACTERISTICS

EVO LINE SILENT M AC	150	200	250	315
Airflow (m³/h)	555	1020	1400	2050
Rotational Speed (rpm)	2645	2445	2440	2430
Motor Power (kW)	0,052	0,110	0,177	0,320
Power Supply (V F Hz)	230 1 50	230 1 50	230 1 50	230 1 50
Motor IP Class	IP X4	IP X4	IP X4	IP X4
IMAX (A)	0,23	0,49	0,79	1,42
Sound Pressure (dB (A))*	33	36	38	40

* Sound Pressure Level at 3 m

PERFORMANCE CURVES

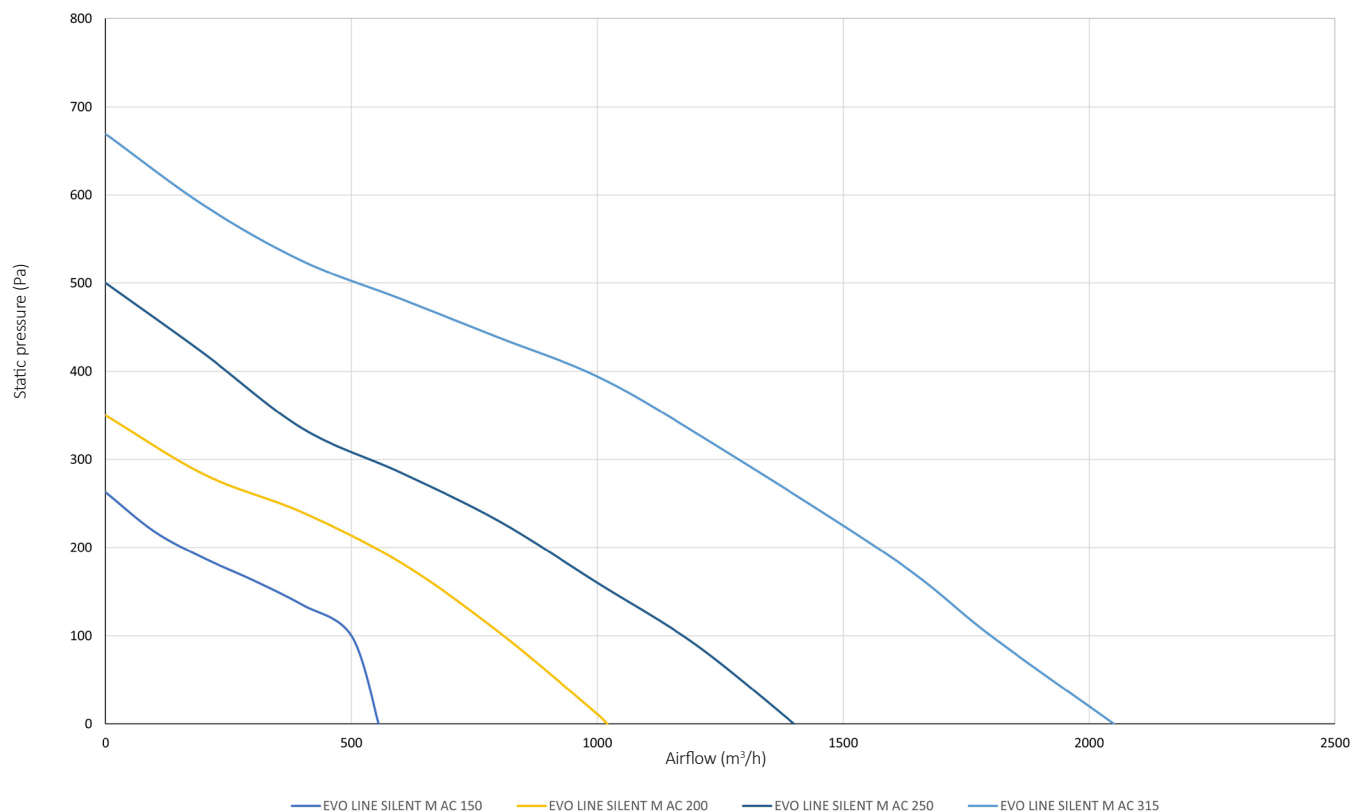

DIMENSIONS

EVO LINE SILENT M AC	150	200	250	315
D (mm)	147	198	248	313
B (mm)	247	293	358	432
B1 (mm)	274	386	445	520
L (mm)	580	550	658	780
H (mm)	260	295	360	434
Weight (kg)	6,1	8	15	25

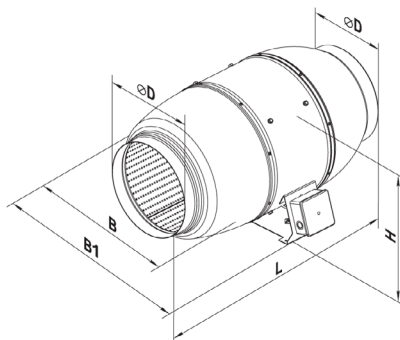
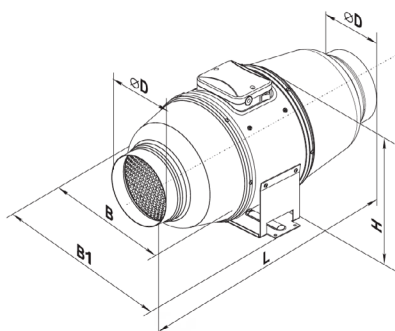

EVO LINE BOX LP EC

[INDEX](#)EC
TechnologyAcoustic
Insulation

In Line Fan

DESCRIPTION

Low-profile ventilation box, EVO LINE BOX LP EC model for in-line installation in circular ducts.

Galvanized steel sheet structure, provided with thermal and acoustic insulation. Duct connection via circular collars equipped with seals.

Available in 4 sizes.

ADVANTAGES

- Low-consumption electronically commutated motor.
- Low profile.
- Compact structure.

ACCESSORIES

- Isolating switch
- 0-10 V airflow controller
- On - Off switch
- Ceiling mounting kit

COMPONENTS

MOTOR

Single-phase 230 V - 50 Hz motor, latest generation EC electronically commutated DC motor with high efficiency, up to 90%. Optimized performance for any operating point. Control via a 0-10 V signal.

FAN

EC duct fan, single-inlet axial-flow impeller with optimized blade profile, balanced according to ISO1940 G2.5 and vibration levels in accordance with AMCA 204.

CHARACTERISTICS

EVO LINE BOX LP EC	100	150	200	250
Airflow (m ³ /h)	278	425	700	1145
Rotational Speed (rpm)	3200	3200	2580	2510
Motor Power (kW)	0,0927	0,0948	0,1016	0,1637
Motor IP Class	IPX4	IPX4	IPX4	IPX4
IMAX (A)	0,75	0,77	0,83	1,34
Sound Pressure (dB (A))*	32	35	37	40

* Sound Pressure Level at 3 m

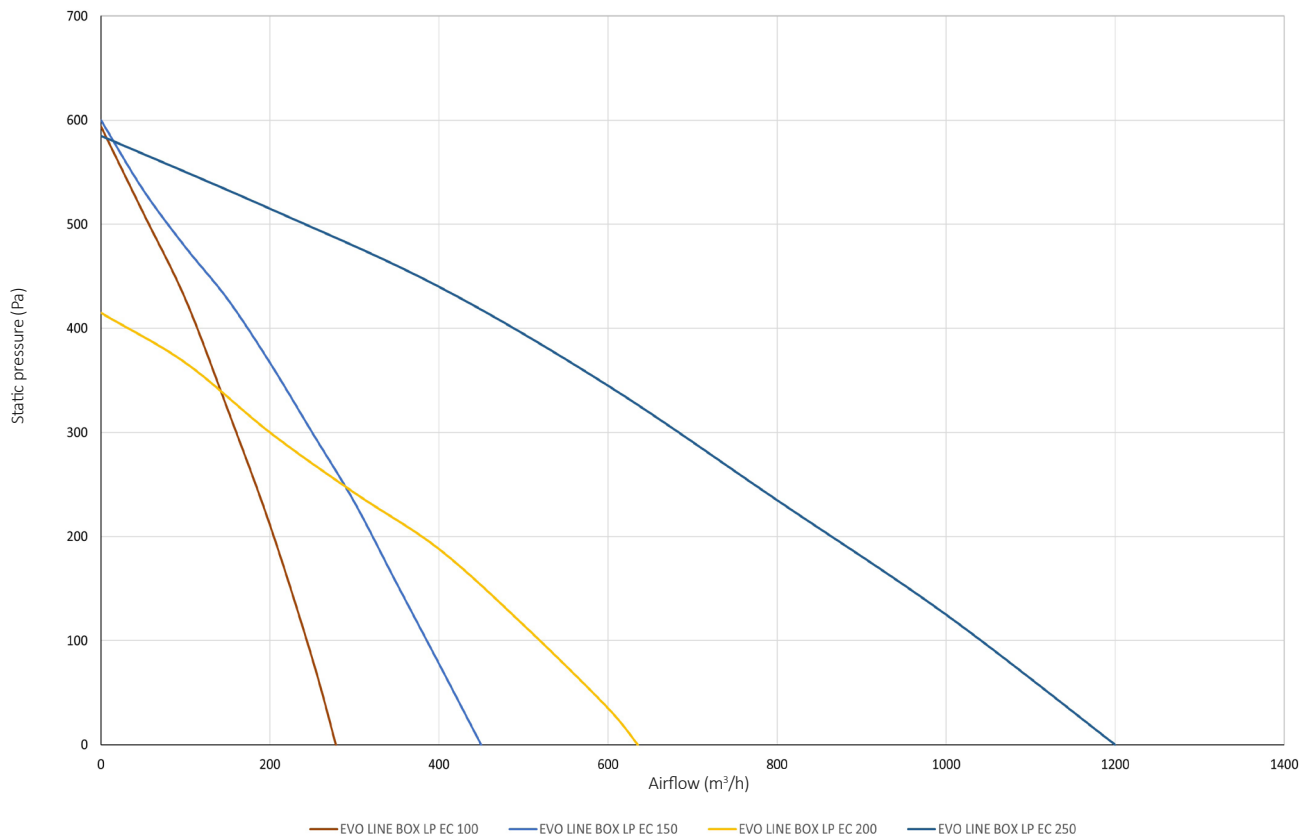
PERFORMANCE CURVES

DIMENSIONS

EVO LINE BOX LP EC	100	150	200	250
D ø (mm)	99	149	199	249
L (mm)	325	325	435	435
L1 (mm)	388	418	503	503
B (mm)	355	385	485	485
B1 (mm)	447	447	590	590
H (mm)	200	220	295	295
Weight (kg)	6,2	7,0	11,5	13,5

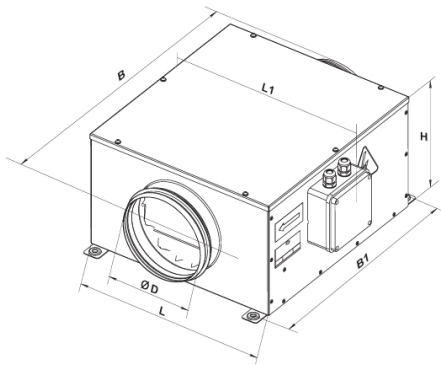

EVO LINE BOX LP AC

INDEX



Acoustic Insulation



In Line Fan

DESCRIPTION

Low-profile ventilation box, EVO LINE BOX LP AC model for in-line installation in circular ducts.

Galvanized steel sheet structure provided with thermal and acoustic insulation. Duct connections equipped with seals.

Available in 3 sizes.

ADVANTAGES

- Acoustic attenuation.
- Low profile.
- Compact structure.

ACCESSORIES

- Isolating switch
- Voltage regulator
- On - Off switch
- Ceiling mounting kit

COMPONENTS

MOTOR

Single-phase 230 V - 50 Hz high-efficiency low-consumption motor, with two speeds. External rotor asynchronous type, directly coupled to the centrifugal impeller with backward-curved blades. Built-in thermal protection with automatic reset and minimum protection rating IPX4. Permanently lubricated ball bearings, ensuring silent and maintenance-free operation.

FAN

Single-inlet fan with backward-curved blades, statically and dynamically balanced in accordance with VDI 2060, class Q2.5.

CHARACTERISTICS

EVO LINE BOX LP AC	150	200	200 S
Airflow (m ³ /h)*	420	730	950
Rotational Speed (rpm)	2600	2550	2570
Motor Power (kW)	0,072	0,103	0,195
Power Supply (V F Hz)	230 1 50	230 1 50	230 1 50
IMAX (A)	0,32	0,45	0,85
Sound Pressure (dB (A))**	36	38	41

* Maximum Airflow

** Sound Pressure Level at 3 m

PERFORMANCE CURVES

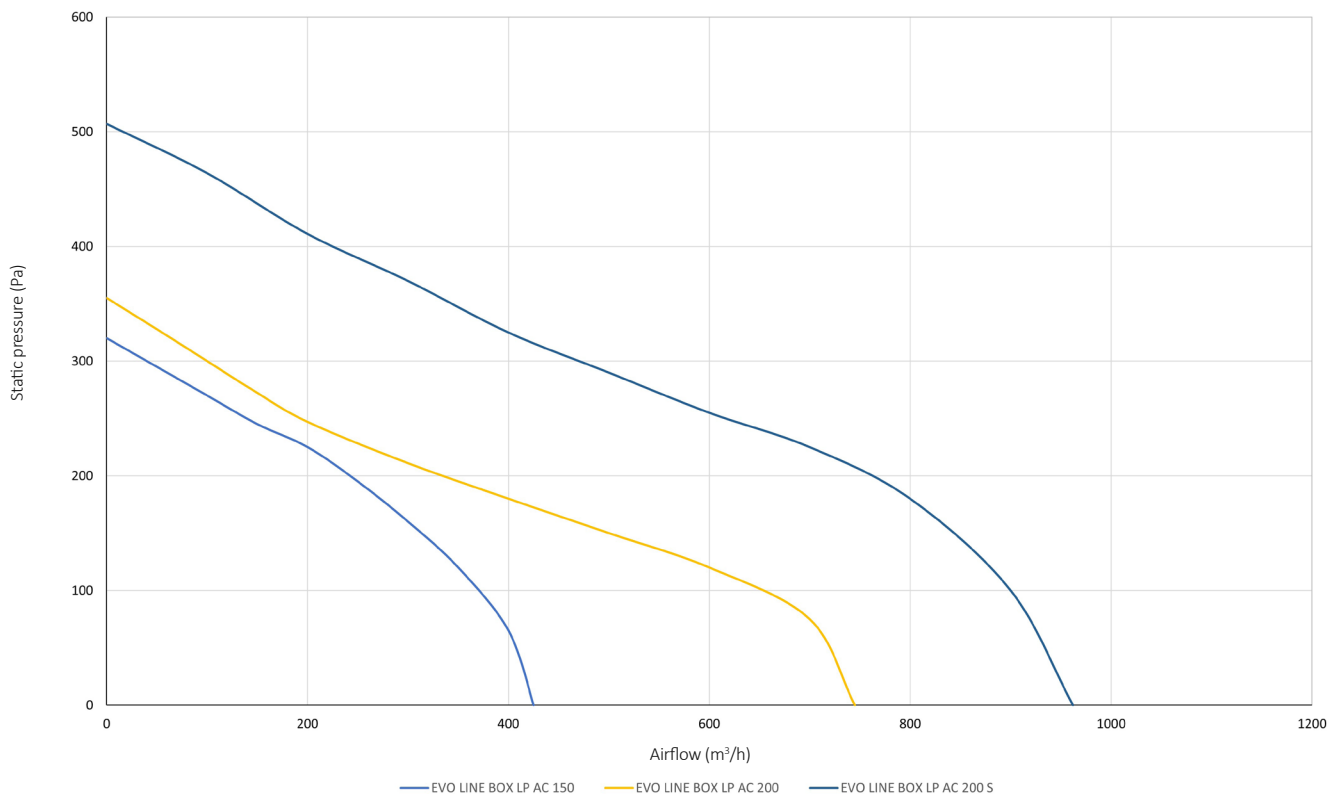

DIMENSIONS

EVO LINE BOX LP AC	150	200	200 S
D (mm)	149	199	199
B (mm)	352	432	432
B1 (mm)	310	368	368
H (mm)	212	287	287
L (mm)	477	588	588
L1 (mm)	410	506	506
L2 (mm)	380	480	480
Weight (kg)	6.4	10	12

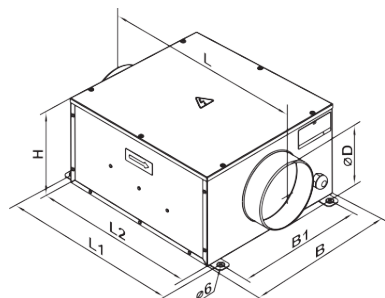

EVO BOX EC

INDEX



Double-panel Structure



Isolating switch included



EC Technology

DESCRIPTION

Ventilation box, EVO BOX EC model with high acoustic attenuation for installation in any location. Airflow up to 6000 m³/h.

Equipped with isolating switch and airflow controller. Modular structure in extruded aluminium profile according to DIN 17615 with 30 mm thickness and reinforced nylon corners. Double-wall panels with 25 mm thickness, with outer face in Magnelis steel with corrosion class C5, inner face in galvanized steel sheet according to EN 10192. The intermediate insulation of the panels is filled with self-extinguishing polystyrene boards 25 mm thick, with a density of 30 kg/m³, providing high resistance to different mechanical stresses. The base of the unit is equipped with threaded rivets for mounting anti-vibration feet (supplied).

Available in 3 sizes, standard version (S) or filter version (F).

VENTILATION

STANDARDS AND CERTIFICATIONS



Class IE4

 Mechanical Protection
IP54

 Corrosion Class
C5

ADVANTAGES

- Low-consumption electronically commutated motor.
- Corrosion class C5.
- 25 mm thick panels.
- Internal speed controller for operating point adjustment.
- Factory-installed isolating switch as standard.

ACCESSORIES

- Airflow controller
- On - Off switch
- Differential air pressure switch
- Rain Roof
- Protection for rain

COMPONENTS

MOTOR

Single-phase internal rotor electronically commutated motor with high efficiency IE4 class, insulation class F, with IP55 mechanical protection.

FAN

Double-inlet centrifugal fans directly driven. Single-phase internal rotor electronically commutated high-efficiency motors, IE4 class.

FILTERS

ePM10 50% / M5 class filter according to EN 779 and ISO 16890. Installed in rails designed to maintain bypass leakage values within F9 class, according to EN 1886.

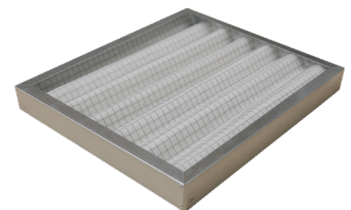



CHARACTERISTICS

EVO BOX - S	29	38	61
Airflow (m³/h)	2803	3764	6001
Static Pressure (Pa)	100		
Maximum Speed (rpm)	2000	2000	1800
Motor Power (kW)	0,37	0,75	1,5
Power Supply (V F Hz)	230 1 50		
Motor IP Class	IP 54		
IMAX (A)	5	6	10
Sound Pressure (dB (A))*	35	40	43

EVO BOX - F	29	38	61
Airflow (m³/h)	2725	3704	5886
Static Pressure (Pa)	100		
Maximum Speed (rpm)	2000	2000	1800
Motor Power (kW)	0,37	0,75	1,5
Power Supply (V F Hz)	230 1 50		
Motor IP Class	IP 54		
IMAX (A)	5	6	10
Sound Pressure (dB (A)) *	35	40	43

* Sound pressure level at 4 m, measured in free field according to ISO 3744

PERFORMANCE CURVES

EVO BOX EC - S

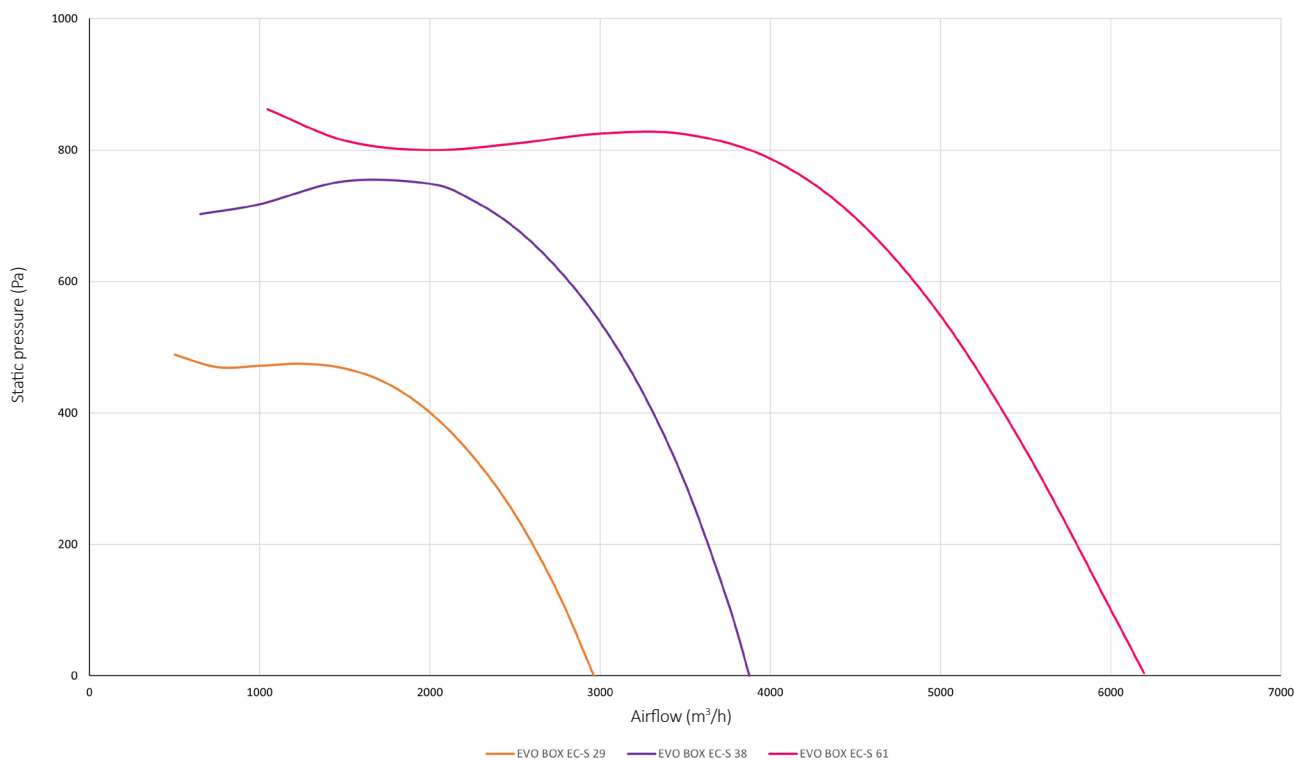

PERFORMANCE CURVES

EVO BOX EC - F

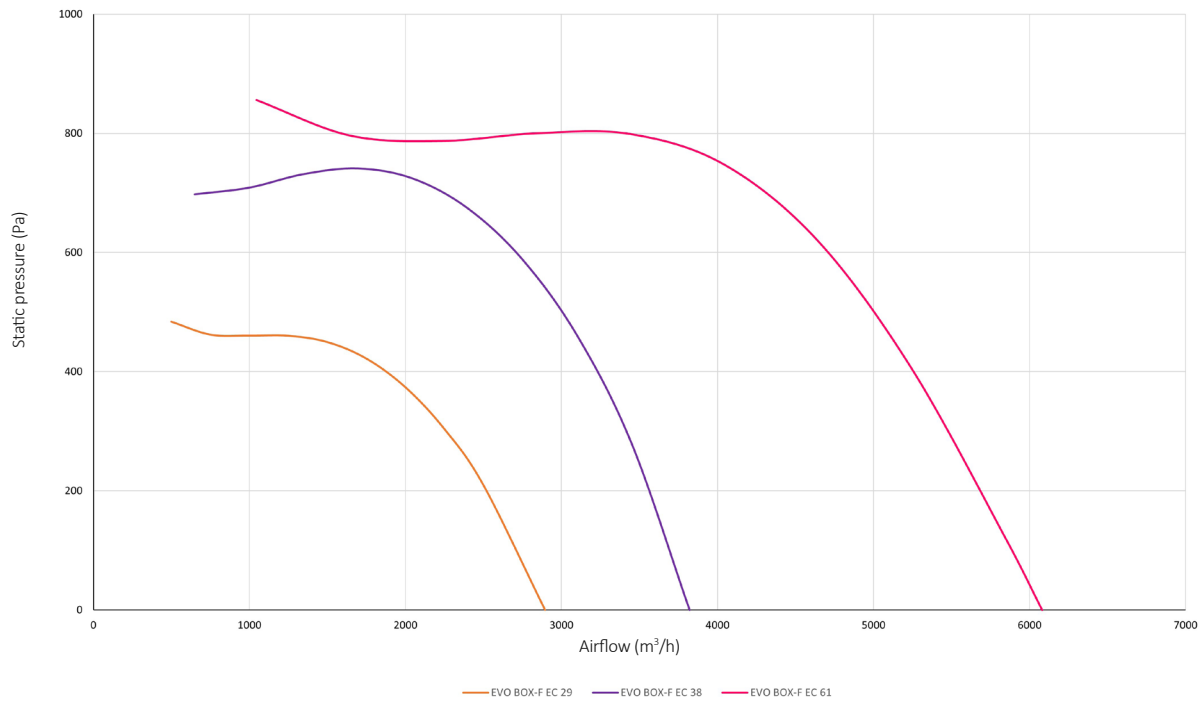

DIMENSIONS

EVO BOX - S	29	38	61
A (mm)	550	600	700
L (mm)	550	600	700
P (mm)	550	600	700
R (mm)	200	253	280
Q (mm)	225	225	325
Weight (kg)	26	34	44
EVO BOX - F	29	38	61
A (mm)	550	600	700
L (mm)	550	600	700
P (mm)	550	600	700
R (mm)	200	253	280
Q (mm)	225	225	325
Weight (kg)	29	38	52

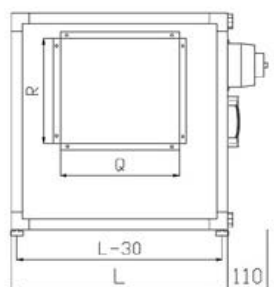
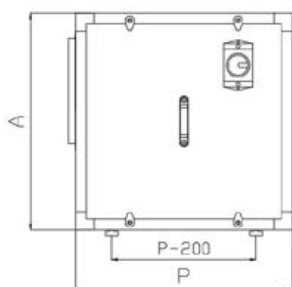



Double-panel structure



Isolating switch included



EC Technology

DESCRIPTION

Ventilation box, PLUG EC model with high acoustic attenuation, allowing installation in any position. Airflow up to 17000 m³/h. Equipped with isolating switch and airflow controller.

Modular structure in extruded aluminium profile according to DIN 17615 with 30 mm thickness and reinforced nylon corners. Double-wall panels with 25 mm thickness, with outer face in Magnelis steel with corrosion class C5, inner face in galvanized steel sheet according to EN 10192. The intermediate insulation of the panels is filled with self-extinguishing polystyrene boards 25 mm thick, with a density of 30 kg/m³, providing high resistance to different mechanical stresses. The base of the unit is equipped with threaded rivets for mounting anti-vibration feet (supplied). Supplied with closed rear panel in the S version and without panel in the filter version.

Available in 9 sizes, standard version (S) or filter version (F).

STANDARDS AND CERTIFICATIONS



Class IES



Mechanical Protection IP55

ADVANTAGES

- Low-consumption electronically commutated motor.
- Corrosion class C5.
- 25 mm thick panels.
- Internal speed controller for operating point adjustment.
- Factory-installed isolating switch as standard.

ACCESSORIES

- Protection for rain
- Rain Roof
- Constant airflow control
- CO₂ control
- On - Off switch
- 0-10 V airflow controller
- Differential air pressure switch

COMPONENTS

MOTOR

External rotor electronically commutated high-efficiency motors, insulation class F, with minimum efficiency class IE4 and IE5, with IP54 and IP55 mechanical protection. Mod-Bus connection (250 to 560).

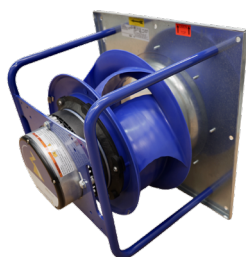

FAN

Direct-drive centrifugal fans with single-inlet high-efficiency backward-curved impeller, statically and dynamically balanced according to ISO 1940 and AMCA 204-G2.5. The PLUG FAN centrifugal fan is directly driven by an EC motor, external rotor electronically commutated high-efficiency, insulation class F, efficiency class IE4 and IE5, and mechanical protection IP54 and IP55.

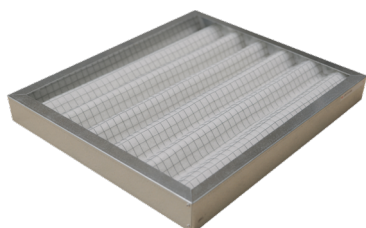

FILTERS

ePM10 50% / M5 class filter according to EN 779 and ISO 16890. Installed in rails designed to maintain bypass leakage values within F9 class, according to EN 1886.

CHARACTERISTICS

PLUG EC - S	190	220	250	315	315-2	350	400	500	560
Airflow (m ³ /h)	910	1393	2979	4828	6098	8039	9249	13 030	17 355
Static Pressure (Pa)	100								
Rotational Speed (rpm)	4500	3000	2950	2920	3640	3400	2500	1860	1750
Motor Power (kW)	0,18	0,2	0,7	1,35	2,5	3,7	2,5	3,5	5
Power Supply (V F Hz)	230 1 50				400 3 50				
Motor IP Class	IP 44	IP 44	IP 44	IP 55	IP 55	IP 55	IP 55	IP 55	IP 55
IMAX (A)	1,4	1,3	3,3	5,8	3,8	5,5	3,8	5,3	7,6
Sound Pressure (dB (A))*	42	37	45	49	55	56	54	53	57
PLUG EC - F	190	220	250	315	315-2	350	400	500	560
Airflow (m ³ /h)	895	1347	2879	4647	5888	7780	8795	12 550	16 496
Static Pressure (Pa)	100								
Rotational Speed (rpm)	4500	3000	2950	2920	3640	3400	2500	1860	1750
Motor Power (kW)	0,18	0,2	0,7	1,35	2,5	3,7	2,5	3,5	5
Power Supply (V F Hz)	230 1 50				400 3 50				
Motor IP Class	IP 44	IP 44	IP 44	IP 55	IP 55	IP 55	IP 55	IP 55	IP 55
IMAX (A)	1,4	1,6	3,3	5,8	3,8	5,5	3,8	5,3	7,6
Sound Pressure (dB (A)) *	42	37	45	49	55	56	54	53	57

* Sound pressure level at 4 m, measured in free field according to ISO 3744

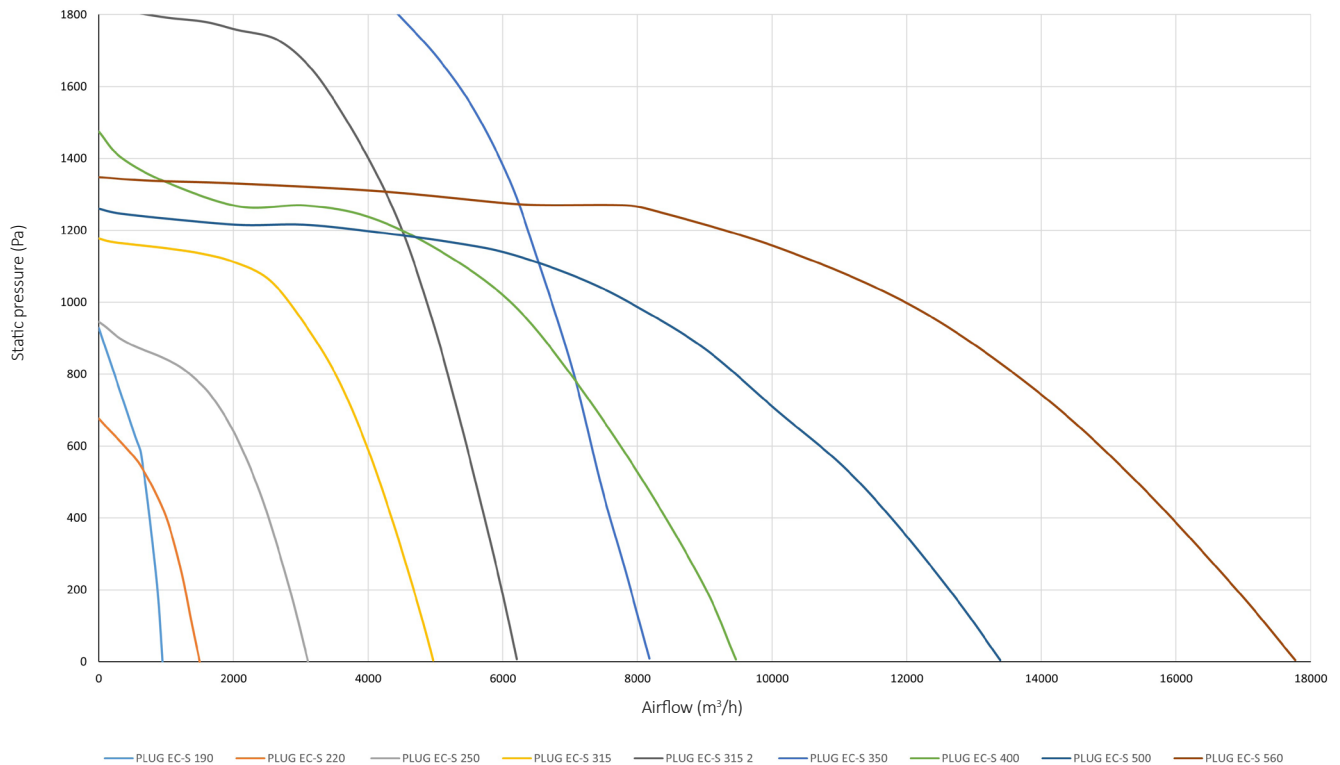
PERFORMANCE CURVES
PLUG EC-S

CHARACTERISTICS

PLUG EC-F

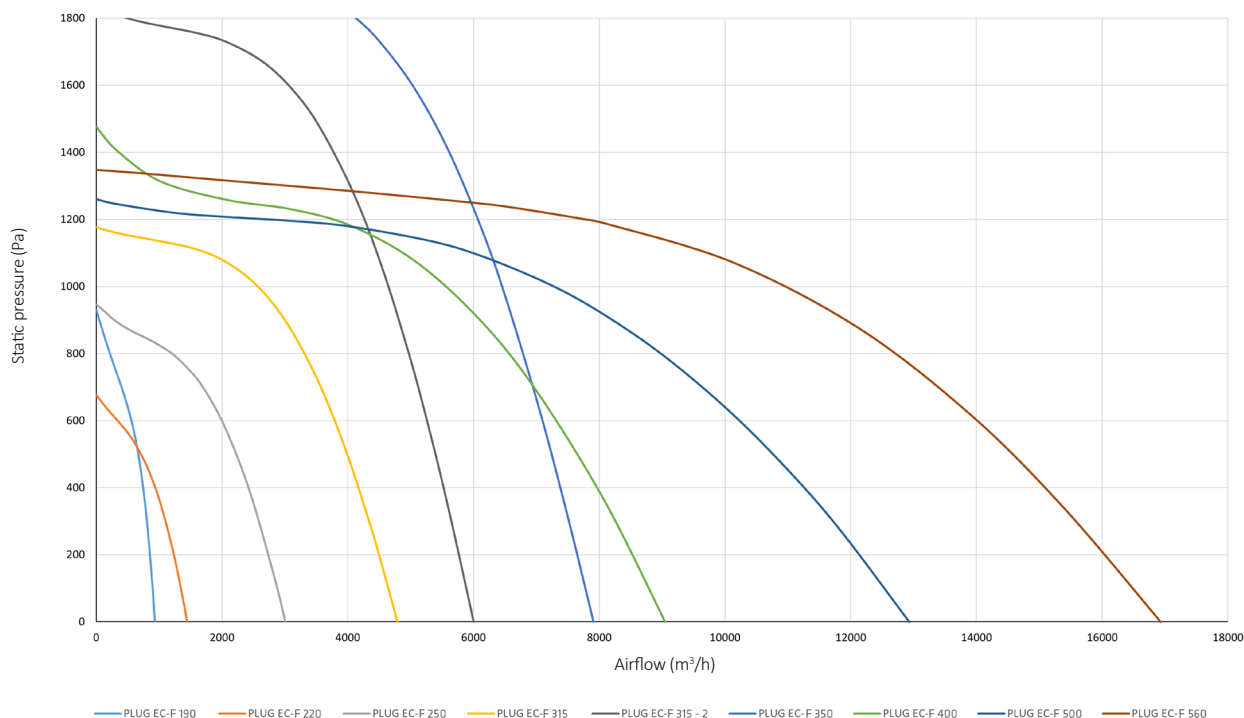

DIMENSIONS

PLUG EC - S	190	220	250	315	315-2	350	400	500	560
A (mm)	360	400	480	515	515	565	615	795	795
L (mm)	360	400	480	515	515	565	615	795	795
P (mm)	360	400	480	600	600	650	700	1000	1000
Weight (kg)	11	14	28	33	35	40	84	112	131
PLUG EC-F	190	220	250	315	315-2	350	400	500	560
A (mm)	360	400	480	515	515	565	615	795	795
L (mm)	360	400	480	515	515	565	615	795	795
P (mm)	360	400	480	600	600	650	700	1000	1000
Weight (kg)	12	15	29	34	36	42	86	114	133

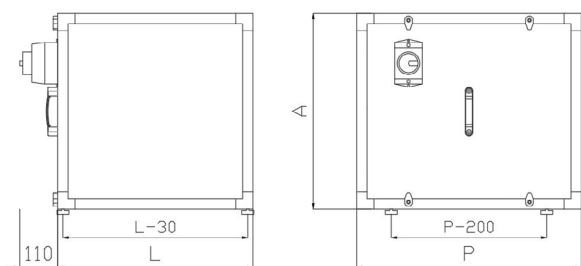

 Structure
Double-panel

 Isolating switch
included

STANDARDS AND CERTIFICATIONS



ADVANTAGES

- High robustness.
- Corrosion class C5.
- 25 mm thick panels.
- Factory-installed isolating switch as standard.

ACCESSORIES

- Protection for rain (intake)
- Protection for rain (exhaust)
- Rain Roof
- Voltage regulator
- Frequency inverter
- On - Off switch
- Differential air pressure switch

COMPONENTS

MOTOR

Single-phase two-speed low-consumption motor, with built-in thermal protection and IP44 protection class.

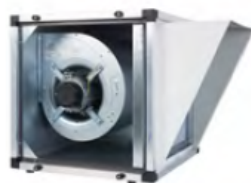

FAN

Double-inlet centrifugal fans with direct-drive motor, high-efficiency forward-curved impeller, statically and dynamically balanced. Directly driven by single-speed AC electric motors with permanent capacitor, built-in automatic reset thermal protection, insulation class F, with mechanical protection IP44 to IP55.

DESCRIPTION

Ventilation box, DA IN model with high acoustic attenuation for installation in any location. Airflow up to 6000 m³/h. Equipped with isolating switch.

Modular structure in extruded aluminium profile according to DIN 17615 with 30 mm thickness and reinforced nylon corners. Double-wall panels with 25 mm thickness, with outer face in Magnelis steel with corrosion class C5, inner face in galvanized steel sheet according to EN 10192. The intermediate insulation of the panels is filled with self-extinguishing polystyrene boards 25 mm thick, with a density of 30 kg/m³, providing high resistance to different mechanical stresses.

The base of the unit is equipped with threaded rivets for mounting anti-vibration feet (supplied). Supplied with closed rear panel in the standard version (S) and without panel in the filter version (F). Available in 8 sizes, standard version or F version with F filter.

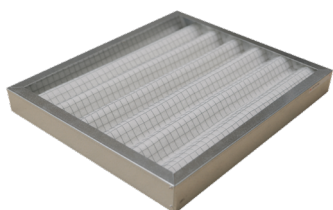
**FILTERS**

ePM10 50% / M5 class filter according to EN 779 and ISO 16890. Installed in rails designed to maintain bypass leakage values within F9 class, according to EN 1886.

CHARACTERISTICS

DA IN - S	7/7- 9	7/7-14	9/9- 9	9/9- 14	10/10- 9	10/10-14	12/9- 9	12/12-14	
Airflow (m ³ /h)	500	1719	1797	2806	2534	4000	5273	6800	
Static Pressure (Pa)	100								
Rotational Speed (rpm)	900	1400	900	1400	900	1400	900	1450	
Motor Power (kW)	0,04	0,13	0,13	0,35	0,21	0,59	0,76	1,5	
Power Supply (V F Hz)	230 1 50							400 3 50	
Motor IP Class	IP 44	IP 44	IP 44	IP 44	IP 44	IP 44	IP 44	IP 55	
IMAX (A)	0,6	1,55	1,3	2,7	2,1	4,5	6,7	3,9	
Sound Pressure (dB (A))*	33	48	42	50	45	53	48	52	

DA IN - F	7/7- 9	7/7-14	9/9- 9	9/9- 14	10/10- 9	10/10-14	12/9- 9	12/12-14	
Airflow (m ³ /h)	145	1622	1634	2690	2400	3938	4953	6500	
Static Pressure (Pa)	100								
Rotational Speed (rpm)	900	1400	900	1400	900	1400	900	1450	
Motor Power (kW)	0,04	0,13	0,13	0,35	0,21	0,59	0,76	1,5	
Power Supply (V F Hz)	230 1 50							400 3 50	
Motor IP Class	IP 44	IP 44	IP 44	IP 44	IP 44	IP 44	IP 44	IP 55	
IMAX (A)	0,6	1,55	1,3	2,7	2,1	4,5	6,7	3,9	
Sound Pressure (dB (A)) *	33	48	42	50	45	53	48	52	

* Sound pressure level at 4 m, measured in a open field according to ISO 3744

PERFORMANCE CURVES

DA IN-S

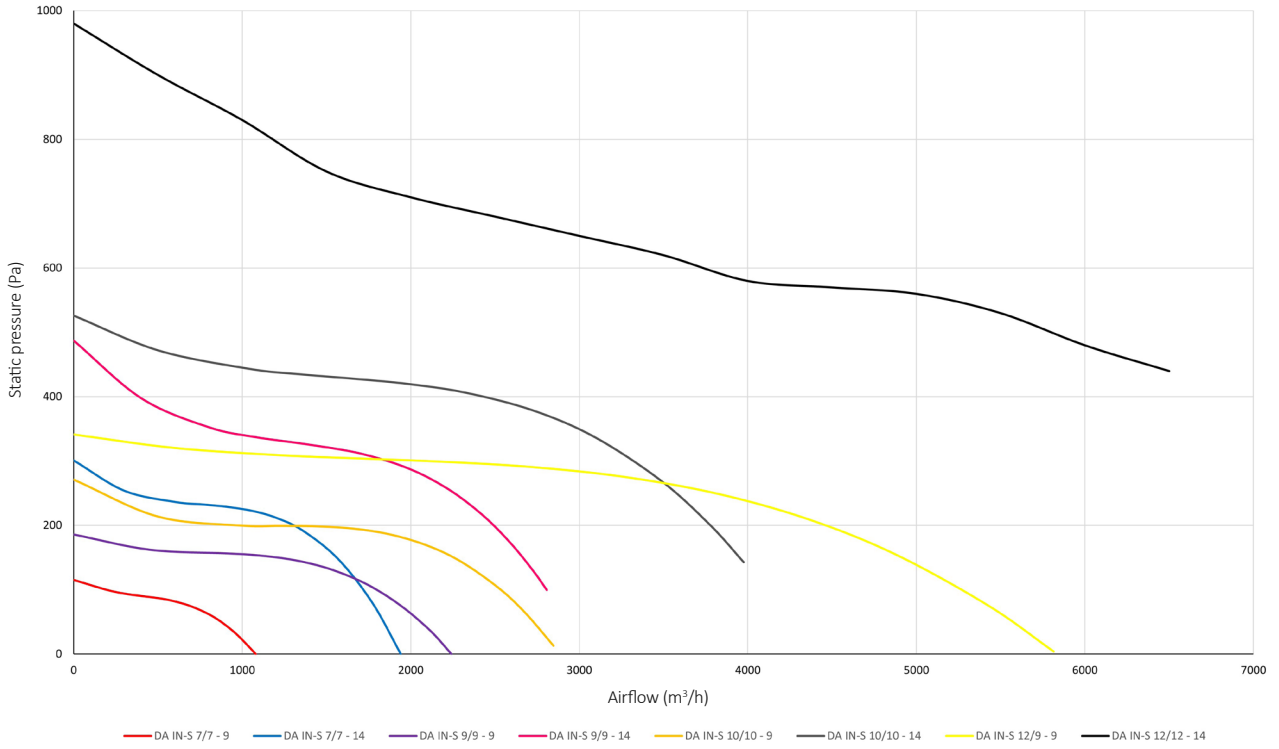

DA IN-F

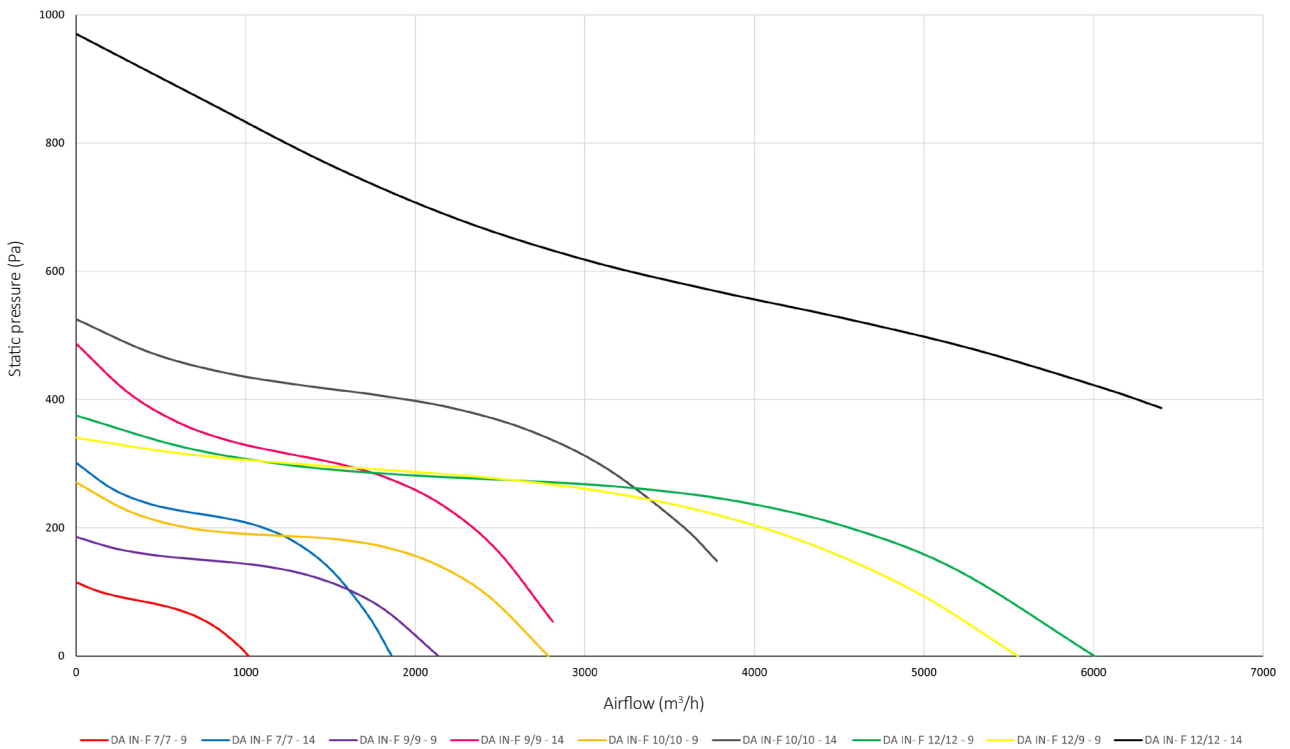

DIMENSIONS

DA IN - S	7/7- 9	7/7-14	9/9- 9	9/9- 14	10/10- 9	10/10-14	12/9- 9	12/12-14
A (mm)	480	480	550	550	600	600	700	700
L (mm)	480	480	550	550	600	600	700	700
P (mm)	480	480	550	550	600	600	700	700
Q (mm)	230	230	300	300	330	330	395	395
R (mm)	210	210	260	260	290	290	340	340
Weight (kg)	25	25	31	31	39	39	52	52

DA IN - F	7/7- 9	7/7-14	9/9- 9	9/9- 14	10/10- 9	10/10-14	12/9- 9	12/12-14
A (mm)	480	480	550	550	600	600	700	700
L (mm)	480	480	550	550	600	600	700	700
P (mm)	480	480	550	550	600	600	700	700
Q (mm)	230	230	300	300	330	330	395	395
R (mm)	210	210	260	260	290	290	340	340
Weight (kg)	26	26	32	32	41	41	54	54

VENTILATION

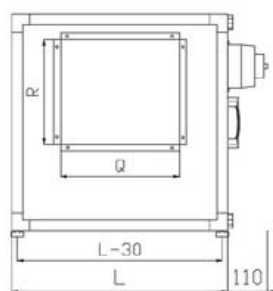
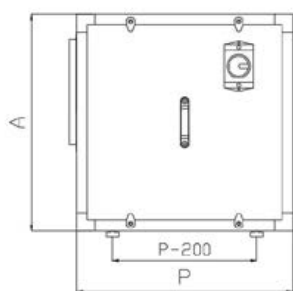



Double-panel Structure



Isolating switch included

DESCRIPTION

Solar dissipation unit, SOLAR model with directly coupled fan, water coil and ePM10 50%/M5 filter. For installation in solar systems. Includes isolating switch.

Modular structure in extruded aluminium profile according to DIN 17615 with 30 mm thickness and reinforced nylon corners. Double-wall panels with 25 mm thickness, with outer face in Magnelis steel with corrosion class C5, inner face in galvanized steel sheet according to EN 10192. The intermediate insulation of the panels is filled with self-extinguishing polystyrene boards 25 mm thick, with a density of 30 kg/m³, providing high resistance to different mechanical stresses.

Available in 5 sizes.

STANDARDS AND CERTIFICATIONS



ADVANTAGES

- High dissipation capacity.
- Corrosion class C5.
- Factory-installed isolating switch as standard.

ACCESSORIES

- Protection for rain
- Rain Roof
- Differential air pressure switch

COMPONENTS

MOTOR

Single-speed single-phase motors or two-speed three-phase motors, with permanent capacitor, built-in automatic reset thermal protection, insulation class F, with minimum efficiency class IE2, with mechanical protection IP20 to IP55, three-phase two-speed motor.

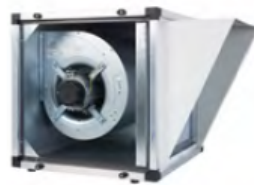

FAN

Double-inlet centrifugal fans with direct-drive motor, high-efficiency forward-curved impeller, statically and dynamically balanced. Directly driven by AC electric motors of single speed and permanent capacitor, with built-in automatic reset thermal protection, insulation class F, with mechanical protection IP44 to IP55. Driven by a voltage regulator.



WATER COIL

Water dissipation coil made of copper tubes with aluminium fins with 2.1 mm / 2.5 mm spacing, supported by a galvanized steel frame sliding on rails, allowing easy maintenance.

CHARACTERISTICS

SOLAR		12	22	30	45	55
Technical characteristics	Fan	7/7-14	9/9-14	10/10-14	12/9-9	12/12-14
	Airflow (m ³ /h)	1300	2800	3800	5000	6400
	Sound Pressure (dB (A)) *	48	50	53	48	52
Inlet air temperature 30°C	Dissipated Power (kW)	11,76	22,14	30,24	44,64	54,88
	Water flow rate (l/h)	540	1044	1404	2088	2556
	Hydraulic pressure drop (kPa)	0,94	2,61	3,36	6,74	2,92
Inlet air temperature 40°C	Dissipated Power (kW)	8	16,24	22,63	34,39	41,21
	Water flow rate (l/h)	360	756	1044	1584	1908
	Hydraulic pressure drop (kPa)	0,48	1,5	2,01	4,23	1,75

* Sound pressure level at 4 m, measured in open field according to ISO 3744

DIMENSIONS

SOLAR	12	22	30	45	55
A (mm)	550	600	650	720	810
L (mm)	550	600	650	800	900
P (mm)	890	950	1050	1100	1200
ø (mm)	3/4"	3/4"	1"	1"	1 1/4"
Weight (kg)	29	32	38	46	56

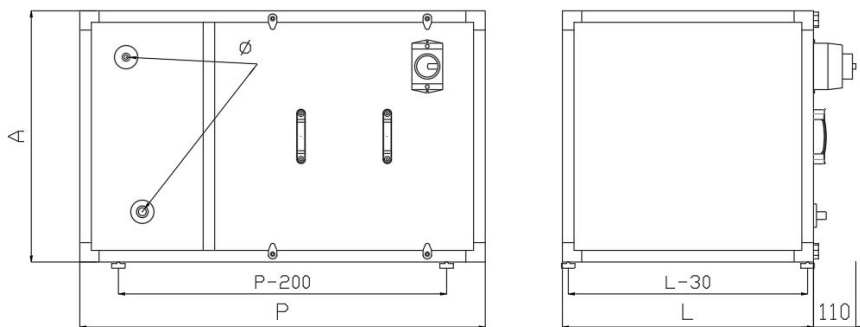

EVO REEL

[INDEX](#)

In Line Fan

DESCRIPTION

Circular electric heater, EVO REEL model for hot air generation in ventilation systems.

Structure and terminal box in galvanized steel sheet, with heating elements in stainless steel. For connection to circular duct, equipped with seal to ensure airtightness. Equipped with 2 safety thermostats, a first level with automatic reset at 50°C and a second level with manual reset at 90°C.

Available in 6 sizes.

ADVANTAGES

- Installation in any position.
- High-quality structure.

ACCESSORIES

- Controller
- Duct / room temperature probe

HEATING ELEMENTS

ELECTRICAL HEATERS

The unit must be installed between ducts with an air filter upstream, ensuring a minimum air velocity of 1.5 m/s and a uniform air distribution. It allows installation in any position with duct connection via fitting.

CHARACTERISTICS

EVO REEL	100	125	150	150	150	200	250	315
Power (kW)	1,8	2,4	3,4	3,6	6	6	6	9
Power Supply (V F Hz)	230 1 50	230 1 50	230 1 50	400 3 50	400 3 50	400 3 50	400 3 50	400 3 50
Airflow (m ³ /h)	130	150	220	265	360	440	440	660
IMAX (A)	7,8	7,8	14,7	5,2	8,7	8,7	8,7	13,0



PERFORMANCE CURVES

VENTILATION

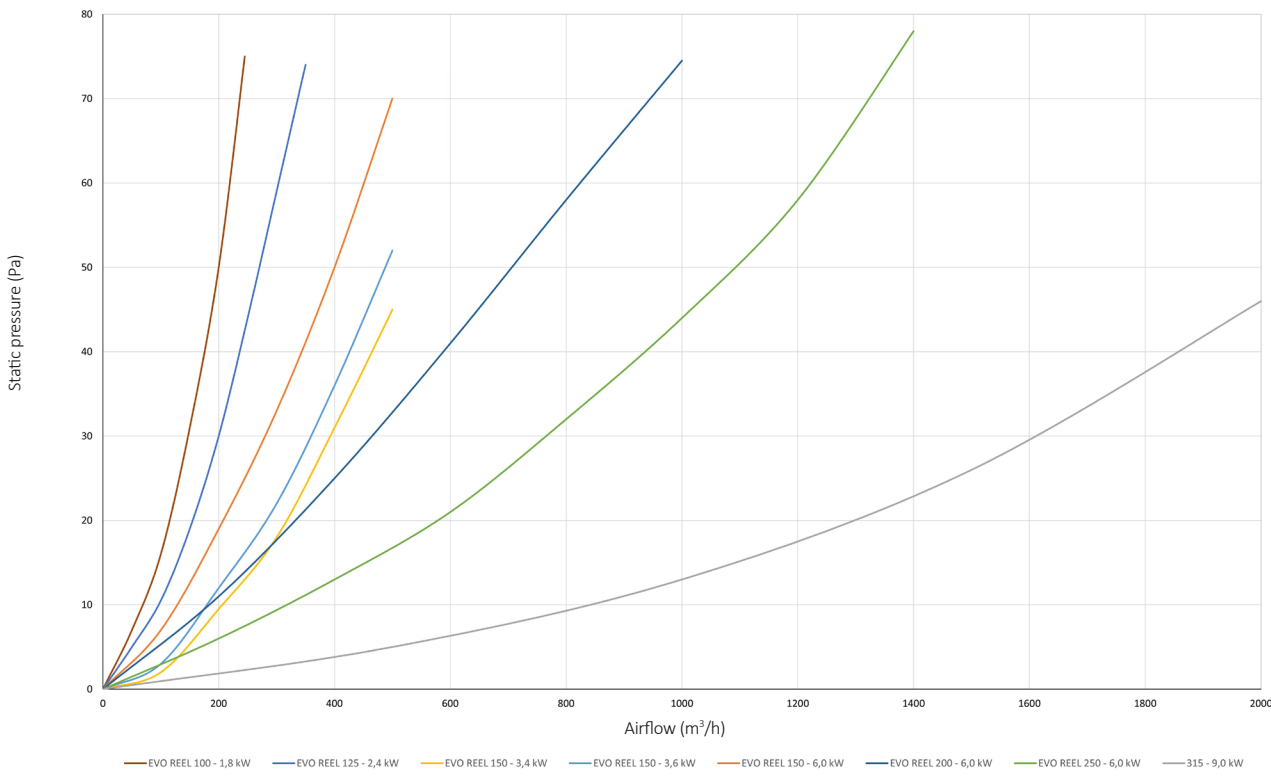
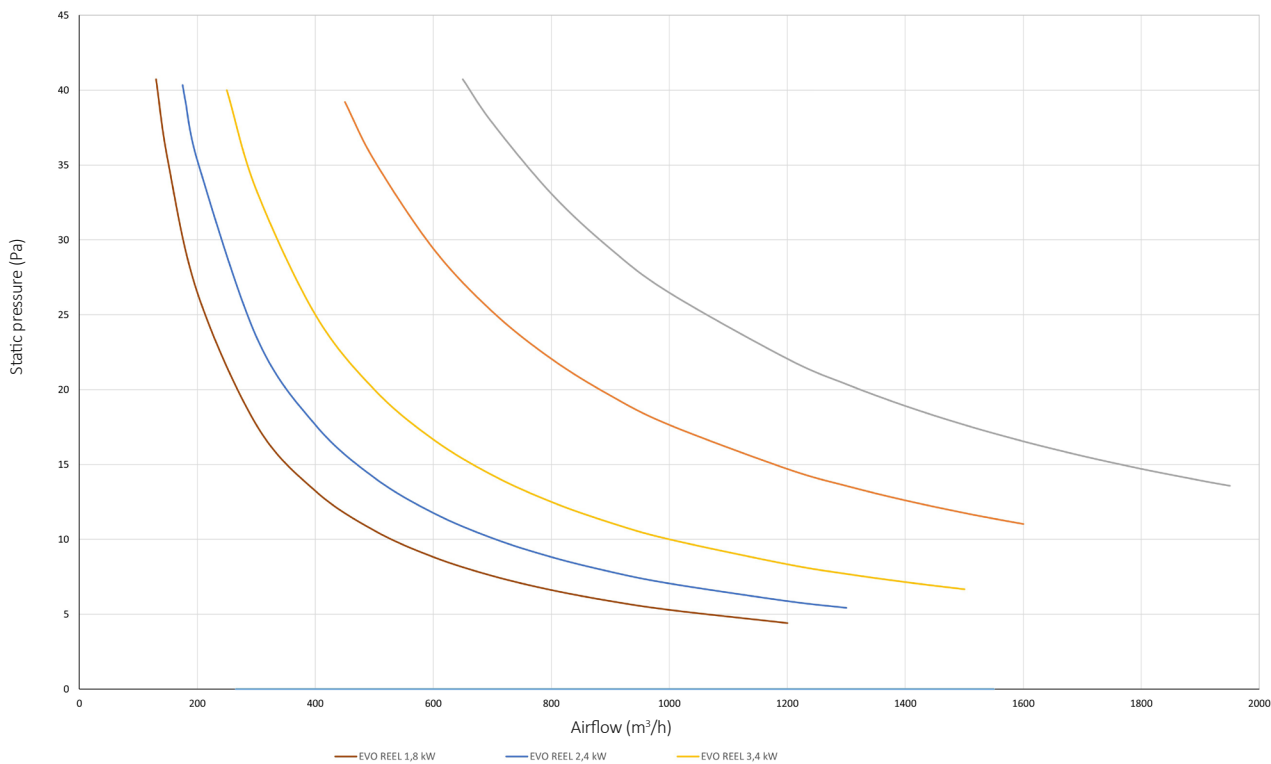

DIMENSIONS

EVO REEL	D100	D125	D150	D150	D150	D200	D250	D315
D ø (mm)	99	124	149	149	149	199	249	313
B (mm)	94	103	120	120	120	150	150	150
H (mm)	207	230	255	255	255	302	356	425
L (mm)	376	376	306	376	376	376	376	376
L1 (mm)	296	296	226	296	296	296	296	296
L2 (mm)	40	40	40	40	40	40	40	40
Weight (kg)	1,7	1,9	2,4	2,8	2,8	3,5	4,6	5,6

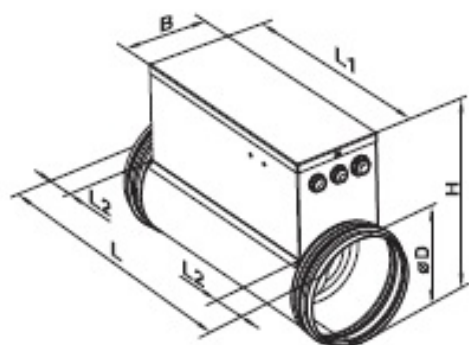

 Instalação
in Line

DESCRIPTION

Filtration module, CFG4 model for installation in duct-interposed ventilation systems.

Structure in galvanized steel sheet. For connection to circular duct. Top access via compression latches to facilitate filter maintenance.

Available in 6 sizes.

ADVANTAGES

- High-quality structure.
- Easy filter maintenance access.

ACCESSORIES

- Differential air pressure switch

PERFORMANCE CURVES

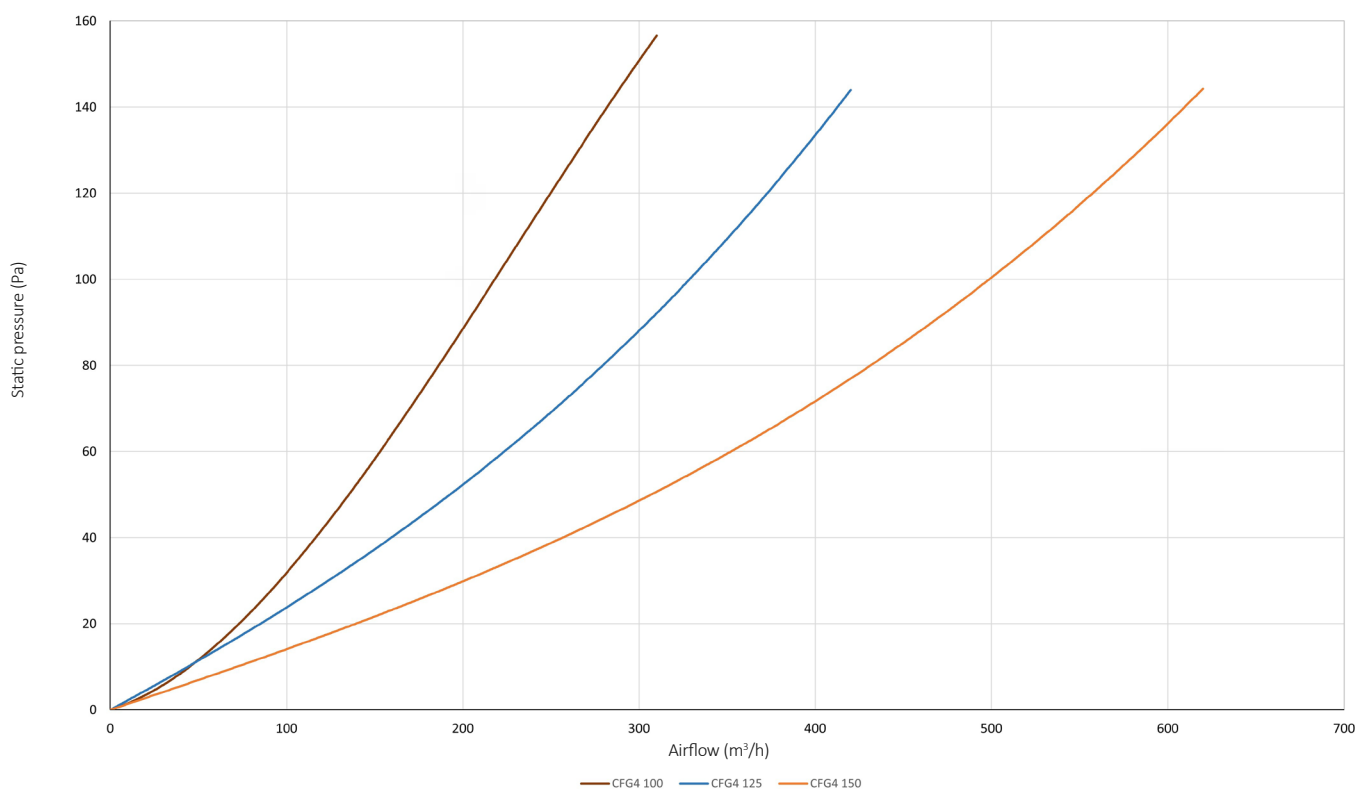

PERFORMANCE CURVES

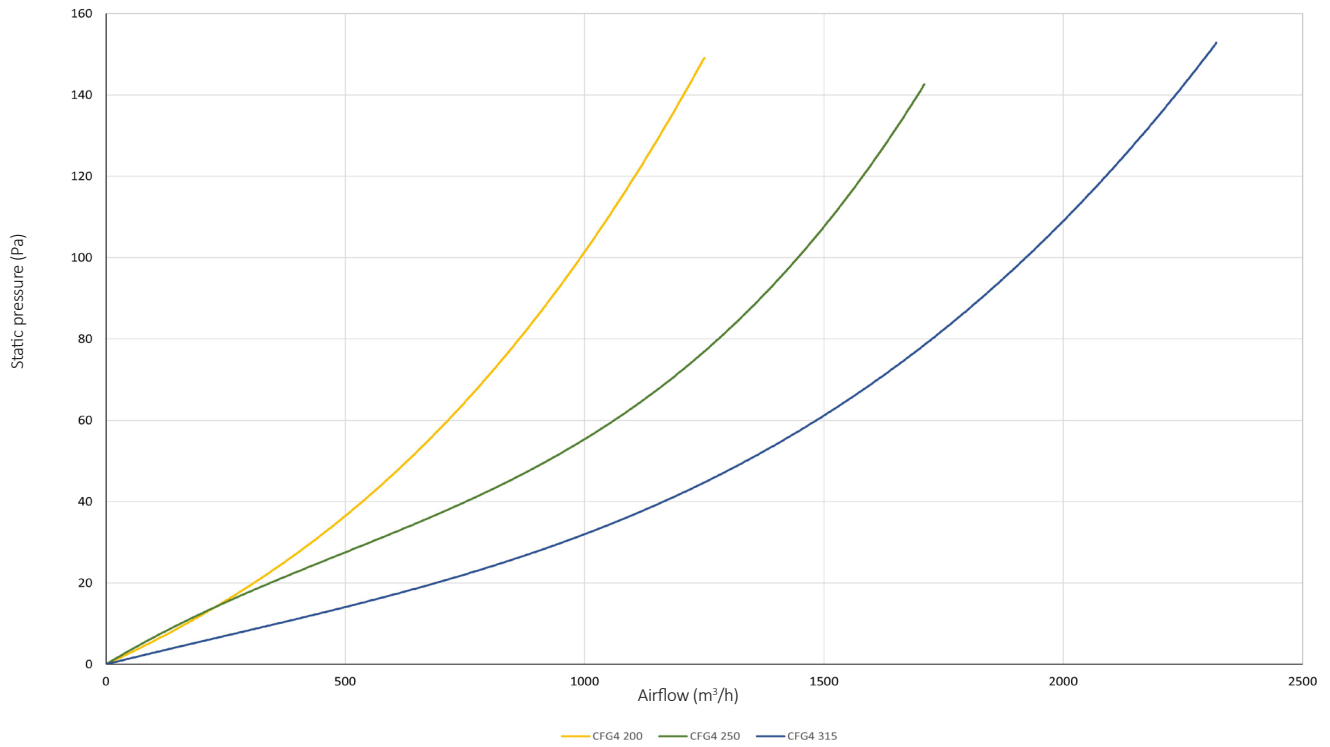

DIMENSIONS

CFG4	100	125	150	200	250	315
D (mm)	99	124	149	199	249	314
B (mm)	210	220	270	320	370	430
H (mm)	175	209	237	279	327	392
L (mm)	215	235	250	275	325	425
L1 (mm)	123	143	158	183	233	333
Weight (kg)	1,4	1,7	2,5	3,1	4,5	6,7

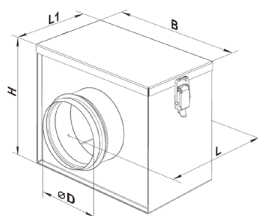



CFF7

INDEX



In Line Fan

DESCRIPTION

Filtration module, CFF7 model for installation in duct-interposed ventilation systems.

Structure in galvanized steel sheet. For connection to circular duct. Top access via compression latches to facilitate filter maintenance.

Available in 6 sizes.

ADVANTAGES

- High-quality structure.
- Easy filter maintenance access.

ACCESSORIES

- Differential air pressure switch

PERFORMANCE CURVES

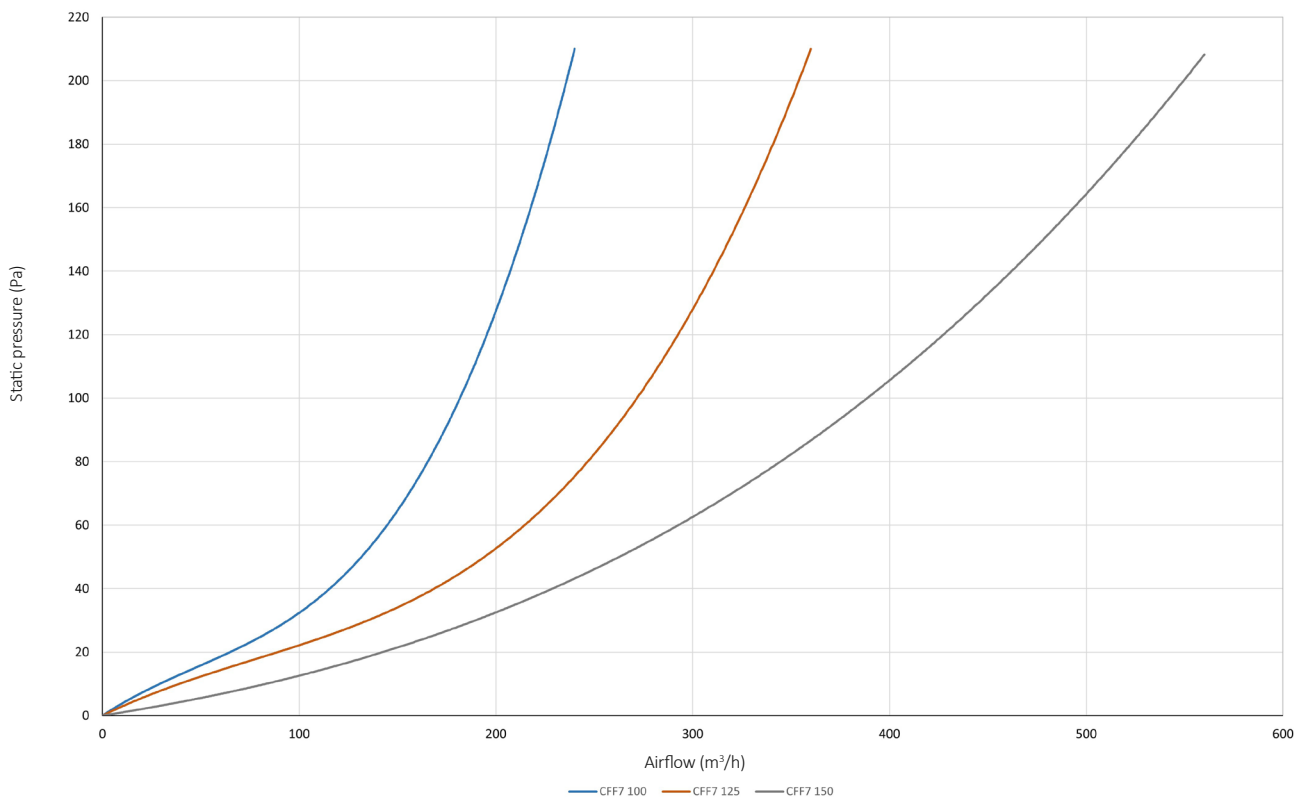

PERFORMANCE CURVES

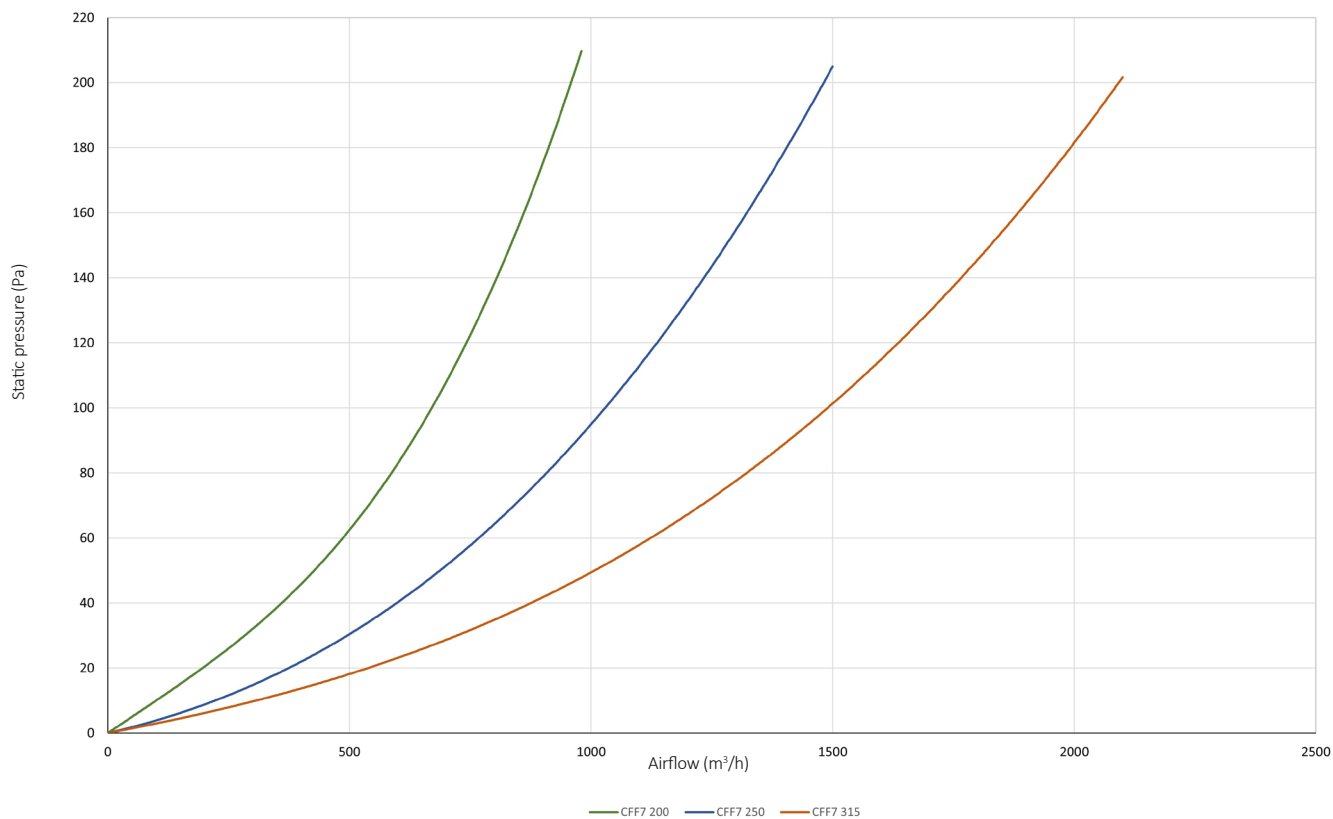

DIMENSIONS

CFF7	100	125	150	200	250	315
D (mm)	99	124	149	199	249	314
B (mm)	210	220	270	320	370	430
B1 (mm)	230	240	290	340	390	450
H (mm)	170	206	236	276	326	390
Weight (kg)	2,41	2,69	3,20	3,76	4,39	5,17

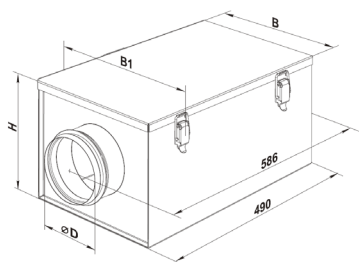

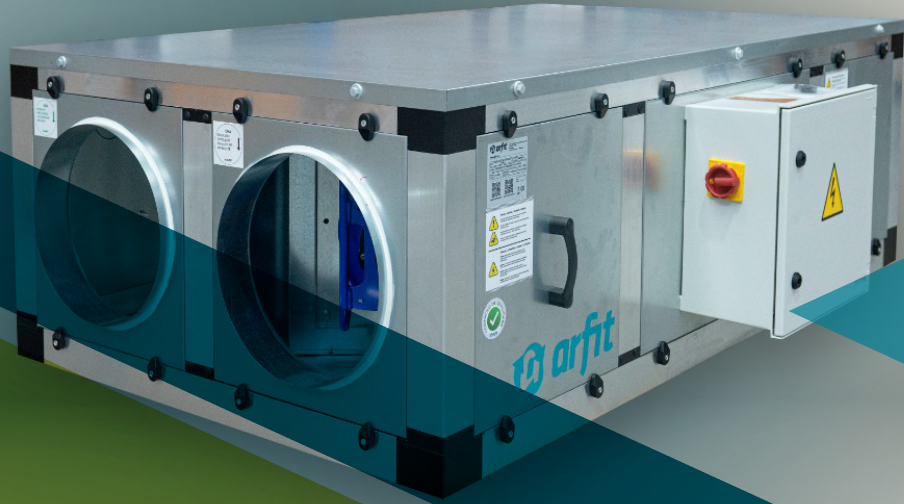

HEAT RECOVERY



VMC 2 C 30C|60C

INDEX



Plug & Play



Remote Control



EC Technology



90% Efficiency



Wi-Fi Connection

DESCRIPTION

Domestic heat recovery unit, VMC 2 C model, available in 2 sizes and reversible airflow, for direct wall installation. It features a low-consumption electronically commutated EC motor and a high-porosity ceramic heat exchanger (efficiency up to 97%). With alternating 75-second cycles, the motor reverses rotation to alternate between extracting stale air and supplying pre-heated fresh air.

Structurally, it features an internal panel with magnetic connection, high-thickness G3 filter, and an automatic shutter that prevents air backflow.

Operation is versatile and can be controlled via integrated unit buttons, remote control, or Wi-Fi digital management (App), enabling automation based on humidity sensors or smart scenarios.

ADVANTAGES

- High-efficiency heat recovery unit (up to 97%).
- Very quiet operation.
- No condensate drainage required.
- Remote control included.
- Smart control (App/Wi-Fi) – advanced control functions.
- Unlimited group control.

ACCESSORIES

- Remote control included
- G3 filter
- F7 filter (optional)
- Integrated humidity sensor

COMPONENTS

FAN

Reversible axial fan with low-consumption EC motor, mounted on ball bearings. G3 filter class ISO coarse > 43%.

PERMUTADOR

Ceramic heat storage exchanger. External grille and internal panel with magnetic closure.



CHARACTERISTICS

VMC 2 C	30C	60C
Maximum airflow (m ³ /h)	30	60
Heat recovery unit efficiency (%)	97	
Motor Power (kW)	0,007	0,0078
Power Supply (V F Hz)	230 1 50	
Motor IP Class	IPX4	
Sound Pressure (dB (A)) *	31,2	32,7

* Sound Pressure Level at 1 m



DIMENSIONS

VMC 2 C	30C	60C
A (mm)	263,5	263,5
B (mm)	239,4	239,4
C (mm)	77,5	77,5
D (mm)	270 - 500	280 - 470
E (mm)	58,5	58,5
F (mm)	231,7	231,7
G Ø (mm)	100	151,2
H Ø (mm)	110	158
Weight (kg)	2,7	4,2

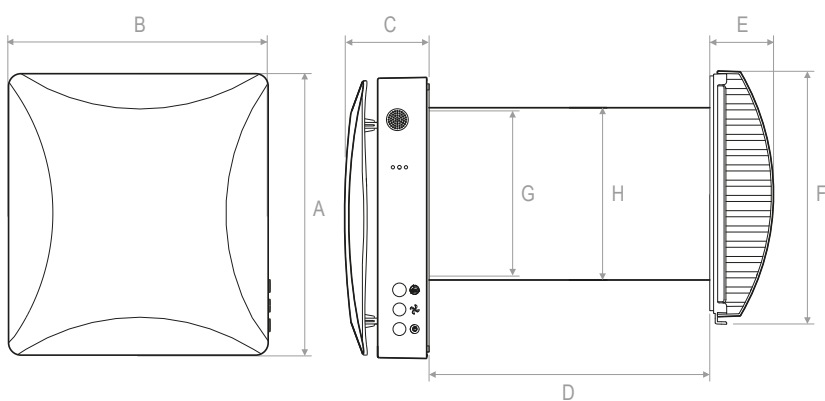

VMC 160H

[INDEX](#)

Plug & Play

 EC
Technology

 90%
Efficiency

DESCRIPTION

Domestic heat recovery unit, VMC 160H model, dual-flow with high-efficiency counterflow heat exchanger (up to 98%), supplied with wired speed controller. Horizontal installation. Self-supporting structure in expanded polypropylene, with filter extraction system and condensate drainage.

ADVANTAGES

- Quiet operation.
- High-efficiency heat recovery.
- Speed controller.

ACCESSORIES

- F7 filter

COMPONENTS

FAN

Plug fan with EC brushless motor.

HEAT EXCHANGER

High-efficiency counterflow heat exchanger made of polymeric material, providing very high heat transfer performance.

FILTERS

Synthetic fiber filters class G4 ISO coarse > 65% (EN 779 / ISO 16890) as standard. Optionally, F7 filter ePM2.5 > 60% (EN 779 / ISO 16890) can be installed on the supply air.

CHARACTERISTICS

VMC	160H
Airflow (m ³ /h)	160
Static Pressure (Pa)	100
Motor Power (kW)	0,027
Power Supply (V F Hz)	230 1 50
IMAX (A)	0,27
Sound Pressure (dB (A)) *	49

* Sound Pressure Level at 3 m



DIMENSIONS

VMC	160H
A (mm)	149
B (mm)	550
C (mm)	255
D (mm)	243
E (mm)	∅156
F (mm)	440
H (mm)	900
I (mm)	1000
K (mm)	268
Weight (kg)	10

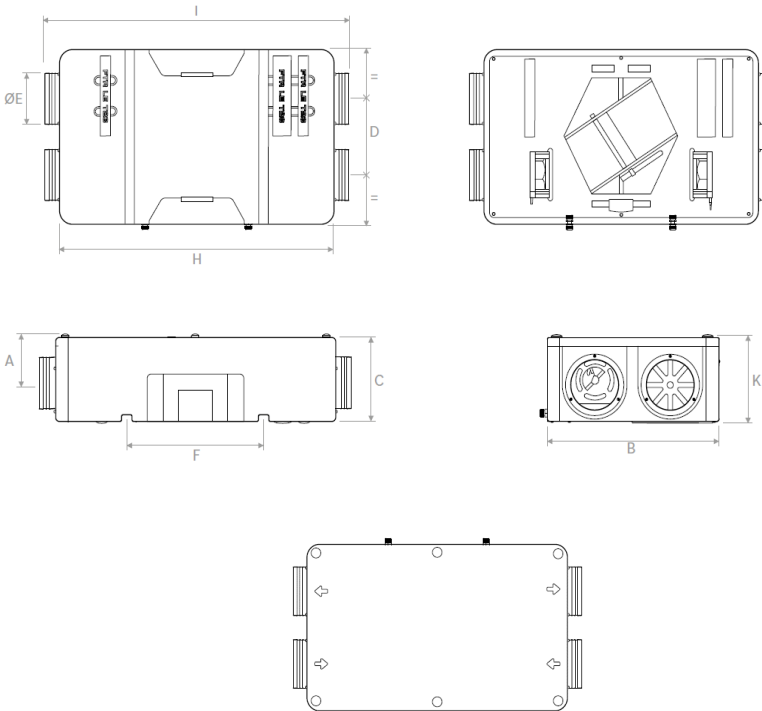

VMC 250 | 320 | 450H

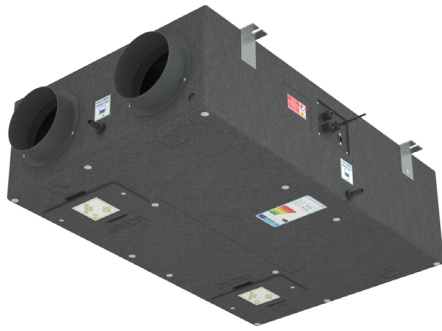
[INDEX](#)

Plug & Play

 EC
Technology

90% Efficiency

DESCRIPTION

Domestic heat recovery unit, VMC 250/320/450H model, dual-flow with high-efficiency counterflow heat exchanger. Equipped with plug & play wireless control system for easy and fast installation. The control unit allows selection of different operating modes and indicates when filter cleaning is required. Horizontal or vertical installation.

Self-supporting structure in expanded polypropylene, with filter extraction system and condensate drainage.

ADVANTAGES

- Quiet operation.
- High-efficiency heat recovery unit.
- Wireless control system.
- Wi-Fi (optional).

ACCESSORIES

- Filter
- Humidity sensor
- CO₂ sensor
- Modbus gateway
- Wi-Fi App model
- Remote control with display

COMPONENTS

FAN

Plug fan with EC brushless motor, single inlet.

HEAT EXCHANGER

High-efficiency counterflow heat exchanger made of polymeric material, providing very high heat transfer performance.

FILTERS

Synthetic fiber filters class G4 ISO coarse > 65% (EN 779 / ISO 16890) as standard. Optionally, F7 filter ePM2.5 > 60% (EN 779 / ISO 16890) can be installed on the supply air.

CHARACTERISTICS

VMC	250H	320H	450H
Airflow (m ³ /h)	250	320	450
Static Pressure (Pa)	100		
Motor Power (kW)	0,050	0,083	0,169
Number of speeds	3 (1 booster)		
Power Supply (V F Hz)	230 1 50		
IMAX (A)	0,46	0,75	1,35
Sound Pressure (dB (A)) *	50	48	54

* Sound Pressure Level at 3 m



DIMENSIONS

VMC	250H	320H	450H
A (mm)	125	129	129
B (mm)	580	578	578
C (mm)	260	277	277
D (mm)	320	271	271
E (mm)	∅156	∅156	∅156
F (mm)	617	1367	1367
G (mm)	609	500	500
H (mm)	900	1330	1330
I (mm)	1005	1431	1431
K (mm)	268	291	291
P (mm)	-	180	180
Weight (kg)	14	20	20

VMC 250H

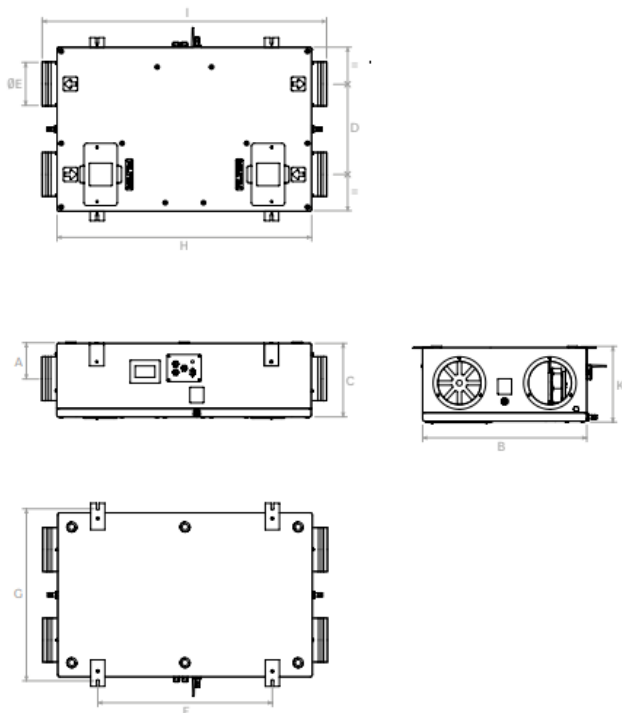

VMC 320 | 450H

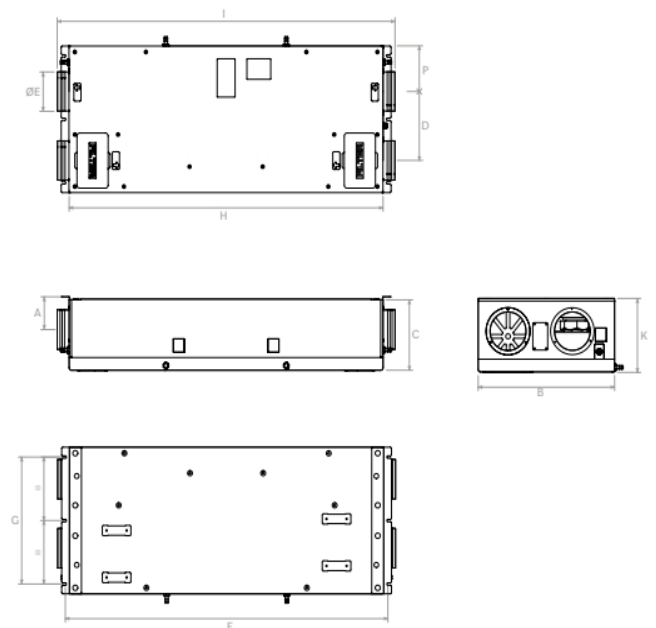

INSTALLATION CONFIGURATIONS

VERTICAL WALL INSTALLATION

TYPE A (STANDARD)

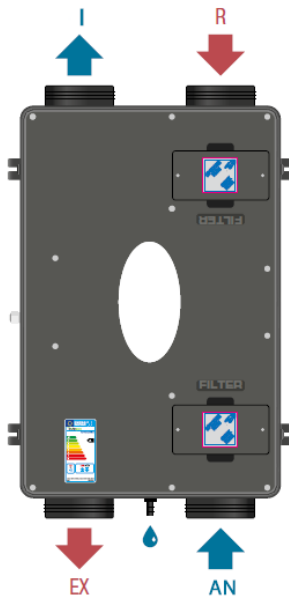

TYPE B

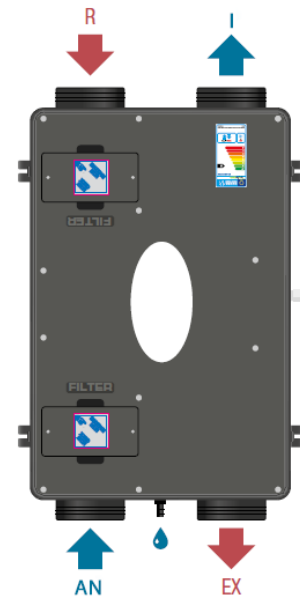

HORIZONTAL CEILING INSTALLATION

TYPE A (STANDARD)

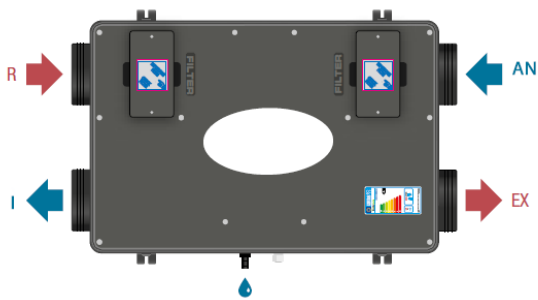

TYPE A1 (STANDARD)

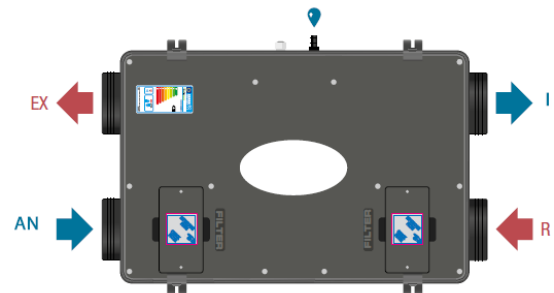

TYPE B

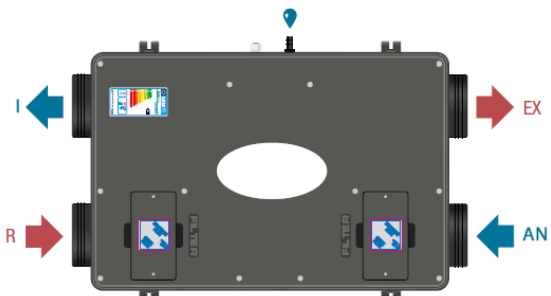

TYPE B1

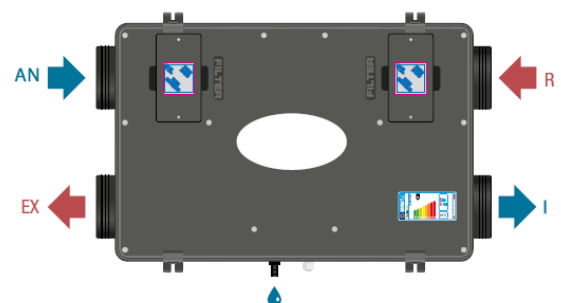

EX = exhaust
 R = return
 AN = fresh air
 I = supply air



VMC 220 | 370V

INDEX



DESCRIPTION

Domestic heat recovery unit, VMC 220/370 V model, dual-flow with high-efficiency counterflow heat exchanger (up to 98%). Equipped with plug & play wireless control system for easy and fast installation. The control unit allows selection of different operating modes and indicates when filter cleaning is required. Vertical installation.

Self-supporting structure in expanded polypropylene externally coated with painted steel sheet, with filter extraction system and condensate drainage.



Plug & Play



EC Technology



Controlled Unit



90% Efficiency



Remote Control

ADVANTAGES

- Quiet operation.
- High-efficiency heat recovery unit.
- Wireless control system.
- Wi-Fi (optional).

ACCESSORIES

- F7 filter
- Humidity sensor
- CO₂ sensor
- Modbus gateway
- Wi-Fi App model
- Remote control with display

COMPONENTS

FAN

Plug fan with EC brushless motor.

HEAT EXCHANGER

High-efficiency counterflow heat exchanger made of polymeric material, providing very high heat transfer performance.

FILTERS

Synthetic fiber filters class G4 ISO coarse > 65% (EN 779 / ISO 16890) as standard. Optionally, F7 filter ePM2.5 > 60% (EN 779 / ISO 16890) can be installed on the supply air.

CHARACTERISTICS

VMC	220V	370V
Airflow (m ³ /h)	220	370
Static Pressure (Pa)	100	
Motor Power (kW)	0,056	0,083
Number of speeds	3 (1 booster)	
Power Supply (V F Hz)	230 1 50	
IMAX (A)	0,41	0,75
Sound Pressure (dB (A)) *	57	

* Sound Pressure Level at 3 m

DIMENSIONS

VMC	220V	370V
B (mm)	600	702
C (mm)	400	617
H (mm)	660	722
E (mm)	ø123	ø160
I (mm)	722	808
M (mm)	427	475
O (mm)	172	287
R (mm)	24	24
S (mm)	87	199
T (mm)	(B-M)/2	128
Weight (kg)	37	41

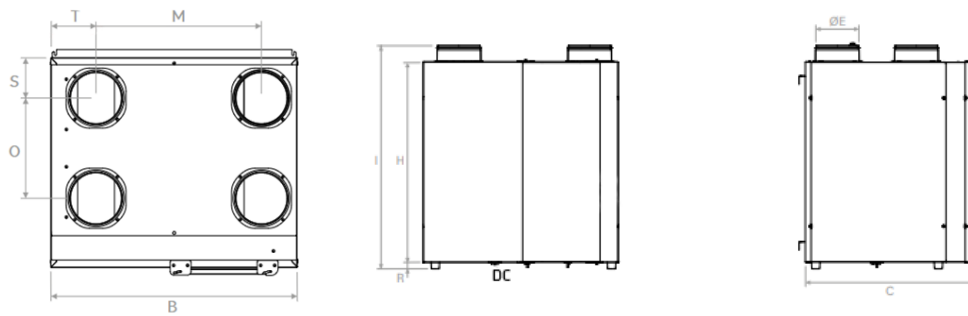

DC = Condensate Drain

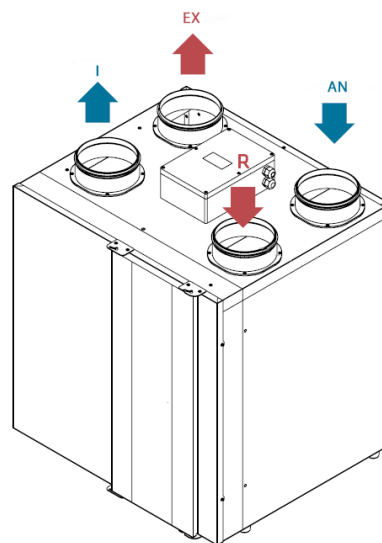
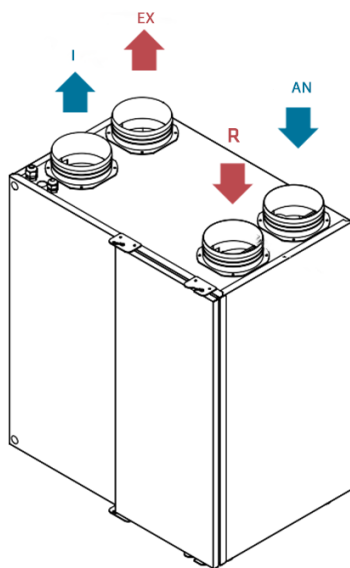
INSTALLATION CONFIGURATIONS
220V
370V

EX = exhaust
 R = return
 AN = fresh air
 I = supply air



VMC2 150H

INDEX

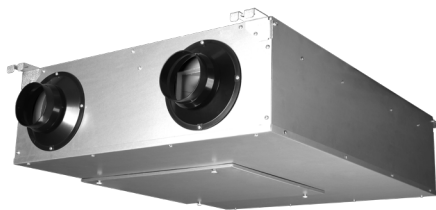

Plug&Play



Low profile

Acoustic
Insulation

DESCRIPTION

Domestic heat recovery unit, VMC2 150H model, low noise level and low-profile design for installation in false ceilings. Easy access for maintenance. Plug&Play control for fast installation with LCD digital display and RS485 (Modbus), selection of operating modes and filter clogging indication. Horizontal or vertical installation.

Self-supporting structure in galvanized steel sheet and high-density EPS with thermal and acoustic insulation. With bottom access for maintenance.

ADVANTAGES

- Compact low-profile unit.
- Quiet operation.
- Wi-Fi (optional).

ACCESSORIES

- F9 filter
- Humidity sensor
- CO₂ sensor
- Wi-Fi module

COMPONENTS

FAN

Double-inlet centrifugal fan equipped with high-efficiency motor with 3 speeds.

HEAT EXCHANGER

High-efficiency heat exchanger with up to 82% heat recovery in polymeric material.

FILTERS

Units are equipped as standard with synthetic fiber filters class G4 ISO coarse > 65% (EN 779 / ISO 16890). Optionally, F9 filter ISO ePM1 > 80% (EN 779 / ISO 16890) can be installed on the supply air.

CHARACTERISTICS

VMC2	150H		
	min.	med.	max.
Rotational Speed (rpm)			
Airflow (m ³ /h)	120	150	150
Static Pressure (Pa)	45	70	90
Motor Power (kW)	0,093	0,098	0,102
Power Supply (V F Hz)	230 1 50		
IMAX (A)	0,45	0,46	0,47
Sound Pressure (dB (A)) *	23	31	35
Recovery Efficiency (%)	82		

* Sound Pressure Level at 3 m

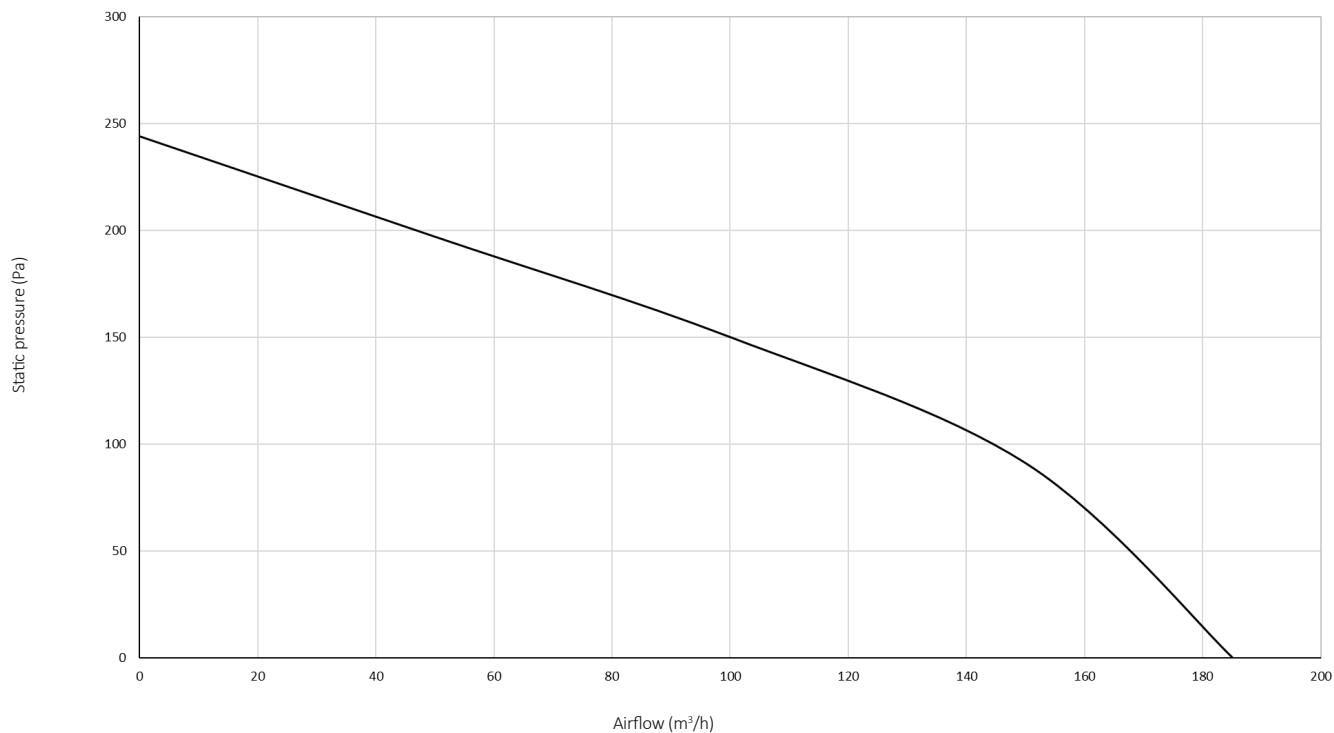
PERFORMANCE CURVES

DIMENSIONS

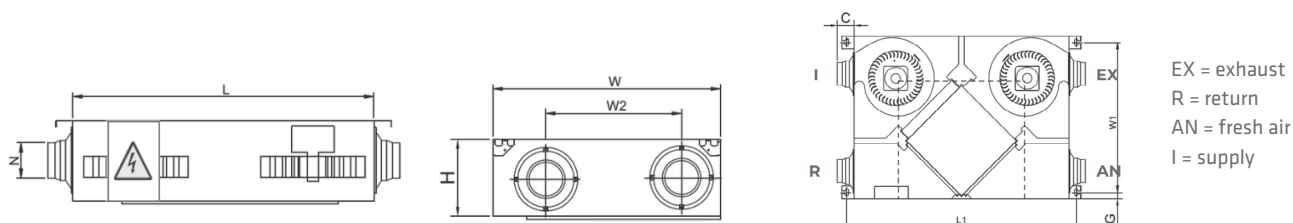
VMC2	150H
L (mm)	860
L1 (mm)	920
W (mm)	685
W1 (mm)	618
W2 (mm)	405
H (mm)	220
C (mm)	70
G (mm)	26
N (mm)	98
Weight (kg)	29



NOTE: MAINTENANCE CLEARANCE AND BOTTOM ACCESS TO UNIT | 500 MM



VMC2 250 | 350H

INDEX

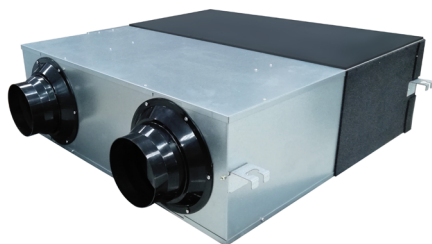

Plug&Play



Low profile

Acoustic
Insulation

DESCRIPTION

Domestic heat recovery unit, VMC2 250H/350H model, low noise level and low-profile design for installation in false ceilings. Easy access for maintenance. Plug&Play control for fast installation with LCD digital display and RS485 (Modbus), selection of operating modes and filter clogging indication. Horizontal or vertical installation.

Self-supporting structure in galvanized steel sheet and high-density EPS with thermal and acoustic insulation.

ADVANTAGES

- Compact low-profile unit.
- Quiet operation.
- Wi-Fi (optional).

ACCESSORIES

- F9 filter
- Humidity sensor
- CO₂ sensor
- Wi-Fi module

COMPONENTS

FAN

Double-inlet centrifugal fan equipped with high-efficiency motor with 3 speeds.

HEAT EXCHANGER

High-efficiency heat exchanger with up to 82% heat recovery in polymeric material equipped with 100% bypass for free cooling.

FILTERS

Units are equipped as standard with synthetic fiber filters class G4 ISO coarse > 65% (EN 779 / ISO 16890). Optionally, F9 filter ISO ePM1 > 80% (EN 779 / ISO 16890) can be installed on the supply air.

CHARACTERISTICS

VMC2	250H			350H		
	min.	med.	max.	min.	med.	max.
Rotational Speed (rpm)						
Airflow (m ³ /h)	200	250	250	300	350	350
Static Pressure (Pa)	90	105	110	110	118	120
Motor Power (kW)	0,17			0,150		
Power Supply (V F Hz)	230 1 50			230 1 50		
IMAX (A)	0,56			0,72		
Sound Pressure (dB (A))	27	34	34,5	31	37	37,5
Recovery Efficiency (%)	81			82		

* Sound Pressure Level at 3 m

PERFORMANCE CURVES

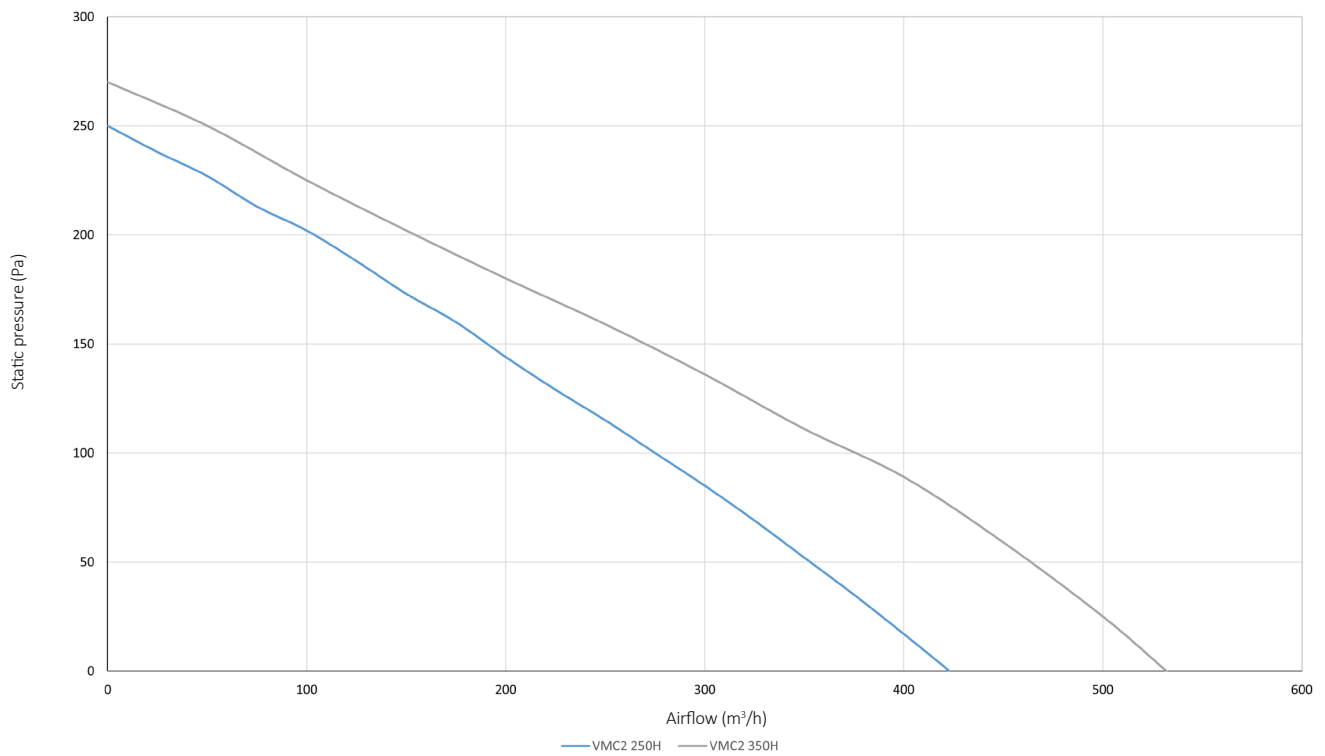

DIMENSIONS

VMC2	250H	350H
L (mm)	744	744
L1 (mm)	675	675
W (mm)	599	804
W1 (mm)	657	862
W2 (mm)	315	480
H (mm)	270	270
H1 (mm)	111	111
C (mm)	100	100
G (mm)	19	19
N (mm)	Φ144	Φ144
Weight (kg)	25	31

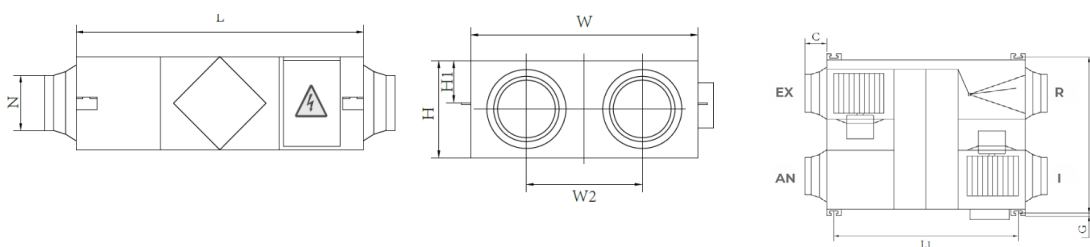

EX = exhaust
 R = return
 AN = fresh air
 I = supply air

MAINTENANCE CLEARANCE AND UNIT ACCESS | 600 MM



VMC2 500H

[INDEX](#)

Plug&Play



Low profile

Acoustic
Insulation

DESCRIPTION

Domestic heat recovery unit, VMC2 500H model, low noise level and low-profile design for installation in false ceilings. Easy access for maintenance. Plug&Play control for fast installation with LCD digital display and RS485 (Modbus), selection of operating modes and filter clogging indication. Horizontal or vertical installation.

Self-supporting structure in galvanized steel sheet and high-density EPS with thermal and acoustic insulation.

ADVANTAGES

- Compact low-profile unit.
- Quiet operation.
- Wi-Fi (optional).

ACCESSORIES

- F9 filter
- Humidity sensor
- CO₂ sensor
- Wi-Fi module

COMPONENTS

FAN

Double-inlet centrifugal fan equipped with high-efficiency motor with 3 speeds.

HEAT EXCHANGER

High-efficiency heat exchanger in polymeric material equipped with 100% bypass for free cooling.

FILTERS

Units are equipped as standard with synthetic fiber filters class G4 ISO coarse > 65% (EN 779 / ISO 16890). Optionally, F9 filter ISO ePM1 > 80% (EN 779 / ISO 16890) can be installed on the supply air.

CHARACTERISTICS

VMC2	500H		
Rotational Speed (rpm)	min.	med.	max.
Airflow (m ³ /h)	500	600	600
Static Pressure (Pa)	79	82	87
Motor Power (kW)	0,195		
Power Supply (V F Hz)	230 1 50		
IMAX (A)	0,96		
Sound Pressure (dB (A))	29	35	39
Recovery Efficiency (%)	76		

* Sound Pressure Level at 3 m

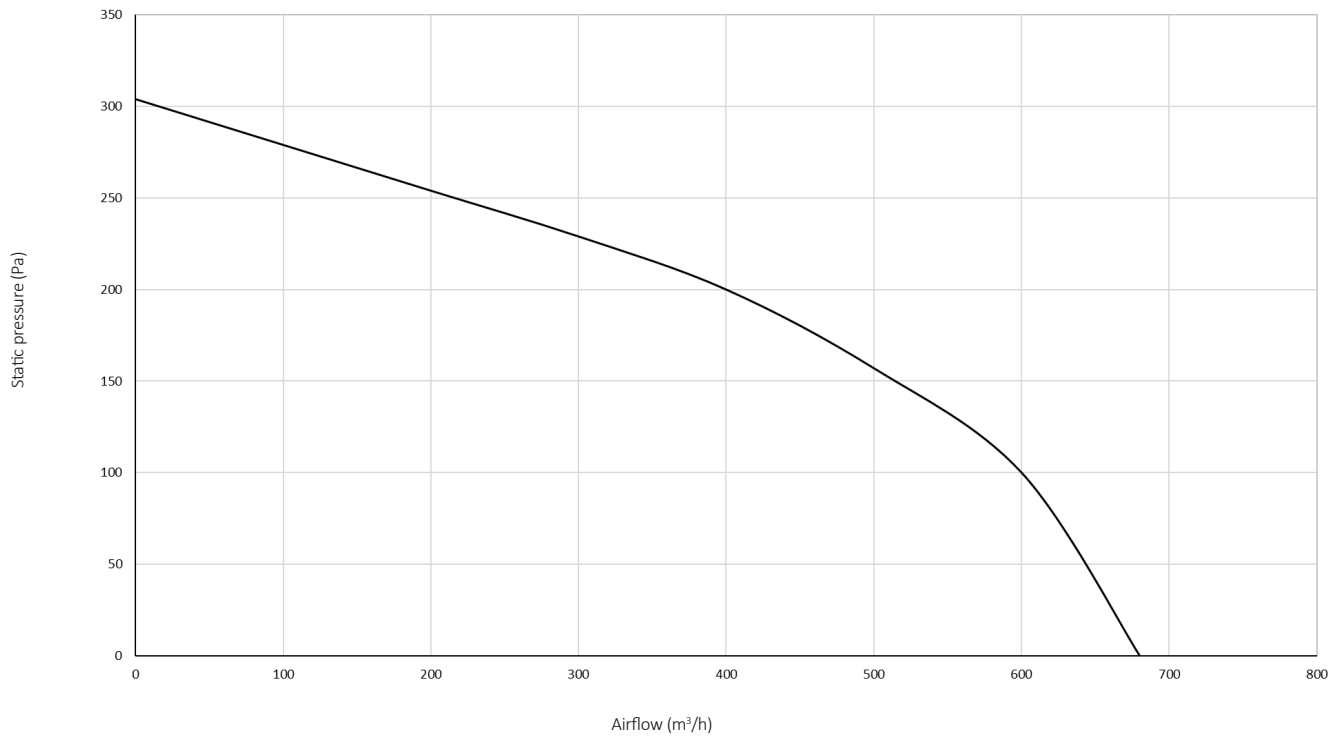
PERFORMANCE CURVES

DIMENSIONS

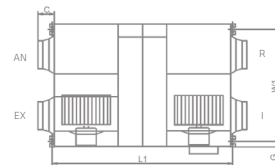
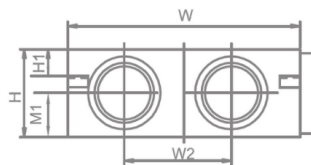
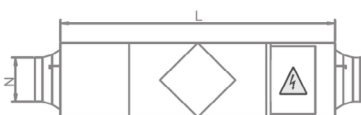
VMC2	500H
L (mm)	867
L1 (mm)	922
W (mm)	902
W1 (mm)	833.5
W2 (mm)	451.5
H (mm)	280
H1 (mm)	115.5
C (mm)	107
G (mm)	26
M1 (mm)	139.5
N (mm)	194
Weight (kg)	34



EX = exhaust
 R = return
 AN = fresh air
 I = supply air

MAINTENANCE CLEARANCE AND UNIT ACCESS | 600 MM



VMC2 650 | 1000H

INDEX

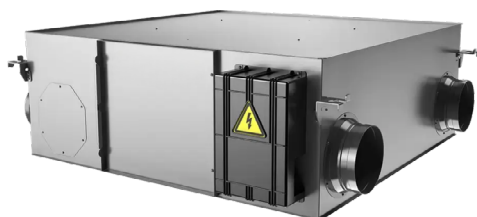

DESCRIPTION

Domestic heat recovery unit, VMC2 650H/1000H model, low noise level and low-profile design for installation in false ceilings. Easy access for maintenance. Plug&Play control for fast installation with LCD digital display and RS485 (Modbus), selection of operating modes and filter clogging indication. Horizontal or vertical installation.

Self-supporting structure in galvanized steel sheet and high-density EPS with thermal and acoustic insulation.



Low profile

Acoustic
InsulationEC
Technology

ADVANTAGES

- Compact low-profile unit.
- Quiet operation.
- Wi-Fi (optional).

ACCESSORIES

- F9 filter
- Humidity sensor
- CO₂ sensor
- Wi-Fi module

COMPONENTS

FAN

Plug fan type equipped with high-efficiency EC motor with 10 speeds.

HEAT EXCHANGER

High-efficiency heat exchanger in polymeric material equipped with 100% bypass for free cooling.

FILTERS

Units are equipped as standard with synthetic fiber filters class G4 ISO coarse > 65% (EN 779 / ISO 16890). Optionally, F9 filter ISO ePM1 > 80% (EN 779 / ISO 16890) can be installed on the supply air.

CHARACTERISTICS

VMC2	650H	1000H
Airflow (m ³ /h)	650	1000
Static Pressure (Pa)	120	170
Motor Power (kW)	0,252	0,420
Power Supply (V F Hz)	230 1 50	230 1 50
IMAX (A)	1,65	2,50
Sound Pressure (dB (A))	35	37
Recovery Efficiency (%)	77	71

* Sound Pressure Level at 3 m

PERFORMANCE CURVES

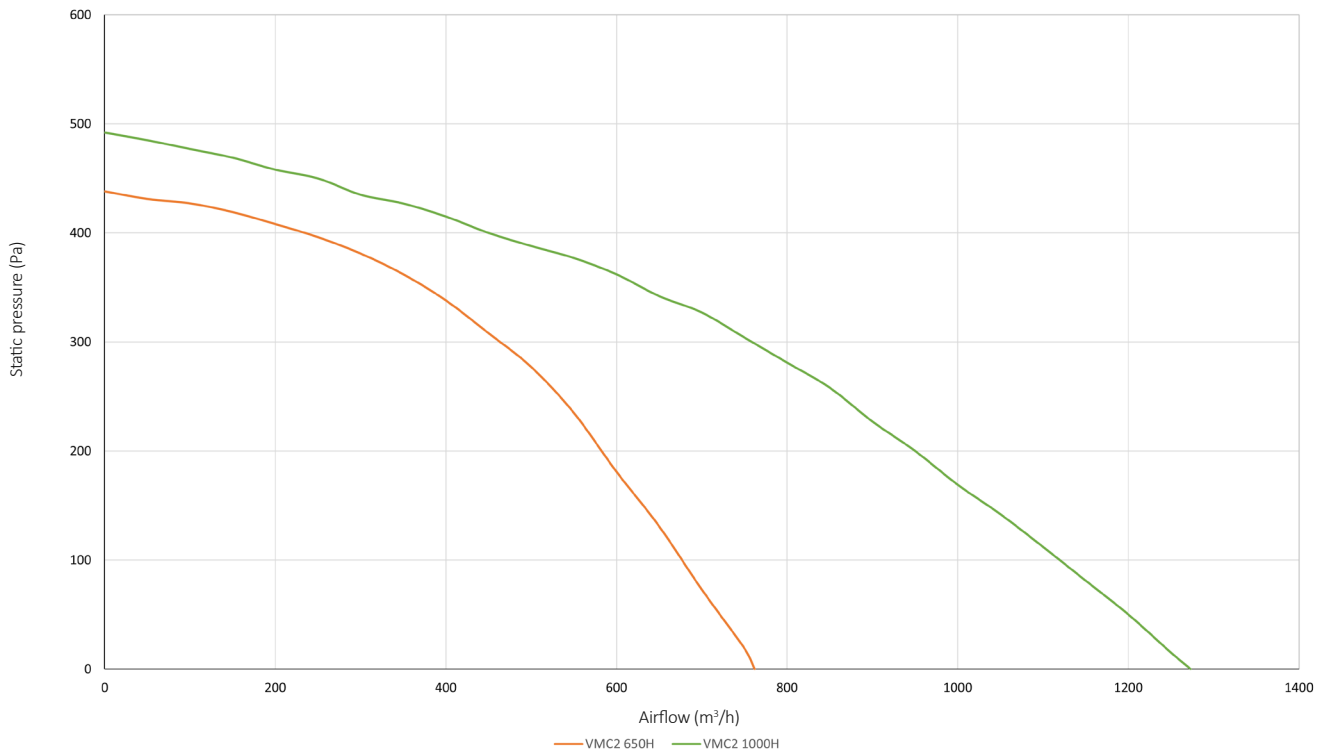

DIMENSIONS

VMC2	650H	1000H
L (mm)	935	1213
L1 (mm)	954	1231
W (mm)	908	1231
W1 (mm)	946,5	1182
W2 (mm)	692	917
H (mm)	404	404
N (mm)	195	244
G (mm)	71	82
A (mm)	202	162
B (mm)	123	164
C (mm)	61	62
Weight (kg)	38	54

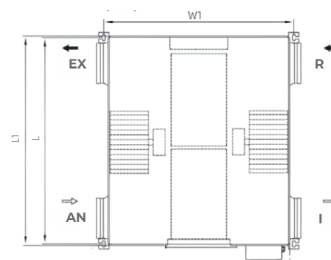
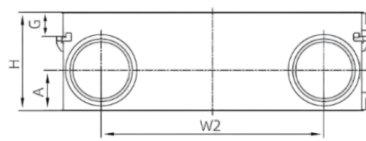
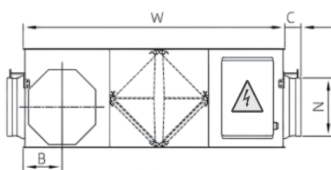

EX = exhaust
 R = return
 AN = fresh air
 I = supply air

MAINTENANCE CLEARANCE AND UNIT ACCESS | 600 MM



ECOevo 2 EC

INDEX



Plug & Play

EC
Technology

Controlled unit

2 Levels of
filtration25 mm
panel

DESCRIPTION

Industrial heat recovery unit, ECOevo 2 EC model, sound-insulated equipment, for indoor or outdoor installation, with removable side panels for easy internal access, with different accessories and configurations. Electrical control panel equipped with isolating switch.

Modular structure in extruded aluminium profile according to DIN 17615 with 30 mm thickness and reinforced nylon corners. Double-wall panels with 25 mm thickness, with outer face in Magnelis steel with corrosion class C5, inner face in galvanized steel sheet according to EN 10192. The intermediate insulation of the panels is filled with self-extinguishing polystyrene boards 25 mm thick, with a density of 30 kg/m³, providing high resistance to different mechanical stresses.

Available in 8 sizes, horizontal or vertical version, with HVAC modules and Smart, Smart CO₂ or Smart Evolution control.

STANDARDS AND CERTIFICATIONS



ADVANTAGES

- Plug & Play monoblock unit.
- Low-consumption electronically commutated motor.
- Corrosion class C5.
- Multiple configurations.
- Possibility of Be.On module integration with direct cloud connection and Be.Smart monitoring.
- 3-way valve and actuator included.

ACCESSORIES

- ePM10 50%/M5 filter
- ePM1 50%/F7 filter
- ePM1 80%/F9 filter
- Protection for rain
- Rain roof
- Constant airflow control
- CO₂ Control

COMPONENTS

FAN

Double-inlet centrifugal fans directly driven. Single-phase internal rotor electronically commutated high-efficiency motors, IE4 class.

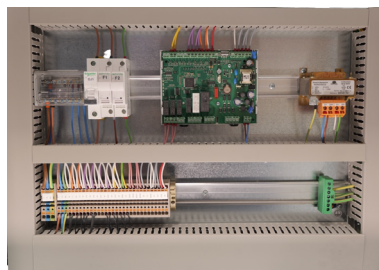

FILTERS

Can be equipped with 2 filters of class ePM10 50%/M5, ePM1 50%/F7 or ePM1 80%/F9 according to EN 779 / ISO 16890. Filters are mounted in parallel in rails designed to maintain bypass leakage values within F9 class according to EN 1886.

HEAT EXCHANGER

High-efficiency parallel-flow heat exchangers with bypass, allowing sensible heat recovery from exhaust air to supply air with efficiencies up to 80% (Eurovent certified). Constructed with stamped aluminium plates with double-fold edges ensuring airtightness up to 1500 Pa.

COMPLEMENTARY MODULES

To complement the recovery range, in addition to specific accessories, a series of optional modules are available. These modules are externally connected to the unit via ductwork.

WATER HEATING MODULE

Water heating coil composed of copper tubes with aluminium fins mechanically expanded, steel or copper headers, and galvanized steel structure. Factory tested at 32 bar to ensure tightness and integrity. Includes 3-way valve and actuator.

CHANGE OVER MODULE

Water heating / cooling coil composed of copper tubes with aluminium fins mechanically expanded, steel or copper headers, and galvanized steel structure. All coils are factory tested at 32 bar. The module is equipped with stainless steel condensate tray. Includes 3-way valve and actuator.

DIRECT EXPANSION MODULE

Direct expansion coil for R410A refrigerant, composed of copper tubes with aluminium fins mechanically expanded, steel or copper headers, and galvanized steel structure. Factory tested at 60 bar. Equipped with stainless steel condensate tray.

ELECTRIC HEATING MODULE

Electric finned heating elements in 8 mm diameter steel tube with 25 x 50 mm fins in the same material and quick-fix screw with M4 threaded terminals. Designed for air heating applications. Mounted in a frame and placed on rails for easy removal.

ACOUSTIC ATTENUATION MODULE

Baffles made of mineral wool, with air-contact surface in non-fragmenting material protected by mesh or micro-perforated sheet, with galvanized steel frame. Mechanical protection IP55.

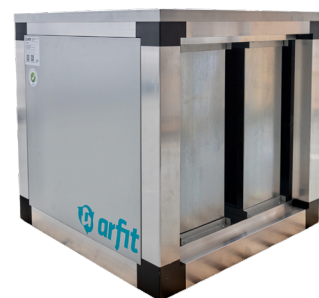
CHARACTERISTICS

ECOEV0 2 EC	6	13	19	23	30	33	45	67
Motor Power (kW)	2 x 0,23	2 x 0,37	2 x 0,37	2 x 0,75	2 x 0,75	2 x 1,5	2 x 1,5	4 x 0,75
Power Supply (V F Hz)	230 1 50							
IMAX (A)	2 x 1,8	2 x 5	2 x 5	2 x 5,8	2 x 5,8	2 x 10	2 x 10	4 x 5,8
Sound Pressure (dB(A)) **	40	38	43	48	48	50	50	51

* Sound pressure level at 4 m, measured in open field according to ISO 3744



COMPLEMENTARY MODULES

WATER HEATING MODULE

Model	Airflow (m³/h)	Air inlet temperature (°C)	Air outlet temperature (°C)	Heating capacity (kW)	Air pressure drop (Pa)	Water flow rate (l/s)	Water pressure drop (kPa)
ECOevo 2 EC 6	600	5	33,9	5,9	37	0,072	2,5
		10	36,4	5,4		0,065	2,1
		15	38,8	4,9		0,059	1,8
	500	5	35,9	5,2	28	0,064	2
		10	38,2	4,8		0,058	1,7
		15	40,5	4,3		0,053	1,4
	400	5	38,4	4,5	20	0,055	1,6
		10	40,5	4,1		0,05	1,3
		15	42,5	3,7		0,046	1,1
ECOevo 2 EC 13	1300	5	34,9	13,1	35	0,16	3,6
		10	37,3	12		0,15	3,1
		15	39,7	10,9		0,13	2,6
	1100	5	36,8	11,8	27	0,14	3
		10	39	10,8		0,13	2,5
		15	41,3	9,8		0,12	2,1
	900	5	39,1	10,4	20	0,13	2,3
		10	41,1	9,5		0,12	2
		15	43,2	8,6		0,11	1,7
ECOevo 2 EC 19	1900	5	36,2	20	35	0,24	9,5
		10	38,6	18,4		0,22	8,2
		15	41	16,8		0,2	6,9
	1650	5	37,8	18,3	29	0,22	8,1
		10	40,1	16,8		0,2	6,9
		15	40,3	15,3		0,19	5,9
	1400	5	39,7	16,4	22	0,2	6,7
		10	41,8	15,1		0,18	5,7
		15	43,9	13,8		0,17	4,9
ECOevo 2 EC 23	2300	5	34	22,5	49	0,27	11,8
		10	36,6	20,7		0,25	10,1
		15	39,2	18,9		0,23	8,6
	2000	5	35,6	20,7	38	0,25	10,1
		10	38	19		0,23	8,7
		15	40,5	17,3		0,21	7,3
	1700	5	37,5	18,6	30	0,23	8,4
		10	39,8	17,1		0,21	7,2
		15	42	15,6		0,19	6,1
ECOevo 2 EC 30	3000	5	31,1	26,4	81	0,32	15,7
		10	33,9	24,3		0,3	13,5
		15	36,7	22,1		0,27	11,4
	2650	5	32,5	24,6	65	0,3	13,8
		10	35,2	22,6		0,28	11,8
		15	37,8	20,6		0,25	10
	2300	5	34	22,5	49	0,27	11,8
		10	36,6	20,7		0,25	10,1
		15	39,2	18,9		0,23	8,6
ECOevo 2 EC 33	3300	5	30,1	28	96	0,34	17,4
		10	33	25,7		0,31	14,9
		15	35,9	23,4		0,29	12,6
	2950	5	31,3	26,2	81	0,32	15,5
		10	34,1	24,1		0,29	13,3
		15	36,9	21,9		0,27	11,2
	2600	5	32,7	24,3	61	0,3	13,5
		10	35,4	22,3		0,27	11,6
		15	38	20,3		0,25	9,8
ECOevo 2 EC 45	4500	5	30	38,3	87	0,47	9
		10	33,1	35,1		0,43	7,7
		15	35,9	31,9		0,39	6,5
	4100	5	31,2	36,3	74	0,44	8,2
		10	34	33,3		0,41	7
		15	36,7	30,2		0,37	5,9
	3700	5	32,3	34,1	60	0,42	7,3
		10	35	31,3		0,38	6,3
		15	37,7	28,5		0,35	5,3
ECOevo 2 EC 67	6700	5	28,3	52,6	132	0,64	18,3
		10	31,3	48,3		0,59	15,7
		15	34,3	44		0,54	13,2
	6100	5	29,2	49,9	111	0,61	16,6
		10	32,2	45,8		0,56	14,2
		15	35,1	41,7		0,51	12
	5500	5	30,3	47	92	0,57	14,9
		10	33,2	43,1		0,53	12,7
		15	36,3	39,3		0,48	10,8

Water temperature 80°C / 60°C

COMPLEMENTARY MODULES

CHANGE OVER MODULE

Heating mode Model	Airflow (m ³ /h)	Air inlet temperature (°C)	Air outlet temperature (°C)	Heating capacity (kW)	Air pressure drop (Pa)	Water flow rate (l/s)	Water pressure drop (kPa)
ECOEV0 2 EC 6	600	5	35,5	6,2	14	0,3	3,1
		10	36,2	5,3		0,26	2,4
		15	36,9	4,5		0,22	1,7
	500	5	36,6	5,3	11	0,26	2,4
		10	37,1	4,6		0,22	1,8
		15	37,7	3,9		0,19	1,3
	400	5	37,8	4,4	8	0,21	1,7
		10	38,2	3,8		0,18	1,3
		15	38,6	3,2		0,15	1
ECOEV0 2 EC 13	1300	5	30,2	11,1	43	0,53	8,8
		10	31,7	9,5		0,46	6,7
		15	33,1	8		0,39	4,9
	1100	5	31,4	9,8	34	0,47	7
		10	32,7	8,5		0,41	5,4
		15	34	7,1		0,34	3,9
	900	5	32,8	8,5	25	0,41	5,4
		10	33,9	7,3		0,35	4,1
		15	35	6,1		0,29	3
ECOEV0 2 EC 19	1900	5	34,2	18,7	22	0,9	14,9
		10	35,2	16,2		0,78	11,5
		15	36,2	13,7		0,66	8,5
	1650	5	35,1	18,2	28	0,81	12,2
		10	36	14,5		0,7	9,5
		15	36,9	12,3		0,59	7
	1400	5	36,2	14,7	24	0,71	9,7
		10	37	12,8		0,62	7,5
		15	37,7	10,8		0,52	5,6
ECOEV0 2 EC 23	2300	5	32,9	21,6	29	1,04	19,3
		10	34,1	18,7		0,9	14,9
		15	35,3	15,8		0,76	11
	2000	5	33,9	19,5	24	0,94	16
		10	34,9	16,9		0,81	12,3
		15	36	14,2		0,69	9,1
	1700	5	34,9	17,2	19	0,83	12,8
		10	35,9	14,9		0,72	9,9
		15	36,8	12,6		0,61	7,3
ECOEV0 2 EC 30	3000	5	32,9	28,2	28	1,36	9,4
		10	34	24,4		1,18	7,3
		15	35,2	20,5		0,99	5,3
	2650	5	33,7	25,7	23	1,24	8
		10	34,8	22,2		1,07	6,1
		15	35,8	18,7		0,9	4,5
	2300	5	34,7	23	19	1,11	6,6
		10	35,6	19		0,96	5
		15	36,5	16,8		0,81	3,7
ECOEV0 2 EC 33	3300	5	32,2	30,3	32	1,46	10,7
		10	33,5	26,2		1,3	8,2
		15	34,7	22		1,06	6
	2950	5	33	27,9	27	1,35	9,2
		10	34,1	24,1		1,16	7,1
		15	35,3	20,3		0,98	5,2
	2600	5	33,9	25,3	22	1,22	7,8
		10	34,9	21,9		1,06	6
		15	35,9	18,5		0,89	4,4
ECOEV0 2 EC 45	4500	5	33	42,6	28	2,06	15,6
		10	34,2	36,9		1,8	12
		15	35,4	31,1		1,5	8,9
	4100	5	33,7	39,7	25	1,92	13,8
		10	34,8	34,4		1,66	10,6
		15	35,8	29		1,4	7,8
	3700	5	34,4	36,7	21	1,77	11,9
		10	35,4	31,8		1,53	9,2
		15	36,4	26,8		1,3	6,8
ECOEV0 2 EC 67	6700	5	30,2	56,9	51	2,75	26,5
		10	31,7	49,2		2,38	20,3
		15	33,2	41,4		2,01	14,9
	6100	5	30,9	53	44	2,57	23,5
		10	32,3	46		2,22	18
		15	33,7	38,8		1,87	13,2
	5500	5	31,6	49,4	37	2,39	20,5
		10	33	42,7		2,06	15,73
		15	34,3	36		1,74	11,5

Water temperature in heating mode 45°C / 40°C



COMPLEMENTARY MODULES

CHANGE OVER MODULE

Cooling mode Model	Airflow (m³/h)	Air inlet temperature (°C)	Air outlet temperature (°C)	Cooling capacity (kW)	Air pressure drop (Pa)	Water flow rate (l/s)	Water pressure drop (kPa)
ECOEOVO 2 EC 6	600	31	19,5	3,6	20	0,17	1,4
		28	17,9	2,6		0,12	0,8
		25	16,1	2		0,093	0,5
	500	31	19,2	3	15	0,14	1
		28	17,2	2,3		0,11	0,7
		25	15,6	1,8		0,085	0,4
	400	31	18,1	2,6	12	0,13	0,8
		28	16,4	2,1		0,1	0,5
		25	14,9	1,6		0,075	0,4
ECOEOVO 2 EC 13	1300	31	21,3	6,7	62	0,32	4,1
		28	19,6	4,7		0,22	2,2
		25	18,7	2,8		0,13	0,9
	1100	31	20,8	6	48	0,28	3,4
		28	19,4	4,1		0,19	1,7
		25	18,1	2,6		0,12	0,8
	900	31	20,2	5,1	36	0,24	2,6
		28	19,5	3,1		0,15	1,1
		25	17,4	2,4		0,11	0,7
ECOEOVO 2 EC 19	1900	31	18,7	13,4	34	0,64	9,5
		28	17,1	10,2		0,49	5,9
		25	15,7	7,2		0,34	3,2
	1650	31	18,2	12,2	27	0,58	8
		28	16,7	9,2		0,44	4,9
		25	15,5	6,4		0,31	2,6
	1400	31	17,6	10,8	22	0,51	6,5
		28	16,2	8,2		0,39	4
		25	15,2	5,6		0,27	2,1
ECOEOVO 2 EC 23	2300	31	19,4	15,3	45	0,73	12
		28	17,7	11,7		0,56	7,5
		25	16,1	8,3		0,4	4,1
	2000	31	18,9	13,9	36	0,66	10,1
		28	17,3	10,6		0,5	6,3
		25	15,9	7,5		0,36	3,4
	1700	31	18,3	12,4	29	0,59	8,3
		28	16,8	9,4		0,45	5,1
		25	15,5	6,6		0,31	2,7
ECOEOVO 2 EC 30	3000	31	19,6	19,1	41	0,91	5,4
		28	18	14,2		0,68	3,2
		25	16,9	9,3		0,44	1,5
	2650	31	19,2	17,5	34	0,83	4,7
		28	17,7	12,9		0,62	2,7
		25	16,9	8		0,38	1,2
	2300	31	18,7	15,8	28	0,75	3,9
		28	17,4	11,5		0,55	2,2
		25	17,2	6,4		0,3	0,8
ECOEOVO 2 EC 33	3300	31	19,97	20,4	47	0,97	6,1
		28	18,3	15,2		0,72	3,6
		25	17	10,1		0,48	1,8
	2950	31	19,6	19,9	40	0,9	5,3
		28	18	14		0,67	3,1
		25	16,9	9,1		0,43	1,5
	2600	31	19,2	17,3	33	0,82	4,5
		28	17,6	12,7		0,61	2,7
		25	16,9	7,8		0,37	1,2
ECOEOVO 2 EC 45	4500	31	19,5	29,2	42	1,39	7,8
		28	17,8	22		1,05	4,7
		25	16,5	15		0,72	2,4
	4100	31	19,2	27,4	36	1,31	6,9
		28	17,6	20,5		0,98	4,2
		25	16,35	13,9		0,66	2,1
	3700	31	18,8	25,5	31	1,21	6,1
		28	17,3	19		0,91	3,7
		25	16,2	12,6		0,6	1,8
ECOEOVO 2 EC 67	6700	31	20	32,2	52	1,53	9,3
		28	18,3	24,4		1,16	5,6
		25	16,7	16,9		0,81	3
	6100	31	19,8	30,5	46	1,45	8,4
		28	18	23		1,1	5,1
		25	16,6	15,9		0,76	2,6
	5500	31	19,4	28,8	40	1,37	7,6
		28	17,8	21,6		1,03	4,6
		25	16,5	14,8		0,7	2,3

Water temperature in cooling mode 7°C / 12°C; Air humidity 50%

COMPLEMENTARY MODULES

DIRECT EXPANSION MODULE

Heating mode Model	Airflow (m ³ /h)	Air inlet temperature (°C)	Air outlet temperature (°C)	Heating capacity (kW)	Air pressure drop (Pa)
ECOevo 2 EC 6	600	5	27	4,5	15
		10	28,7	3,8	
		15	30,3	3,1	
	500	5	28,3	4	11
		10	29,8	3,4	
		15	31,2	2,8	
	400	5	29,9	3,4	7
		10	31,1	2,9	
		15	32,3	2,4	
ECOevo 2 EC 13	1300	5	21,5	7,3	62
		10	23,9	6,2	
		15	26,4	5,1	
	1100	5	22,7	6,6	46
		10	24,9	5,6	
		15	27,2	4,6	
	900	5	24,1	5,8	32
		10	26,2	5	
		15	28,2	4,1	
ECOevo 2 EC 19	1900	5	28,2	15	23
		10	30	12,9	
		15	31,7	10,8	
	1650	5	29,4	13,7	18
		10	30,9	11,8	
		15	32,5	9,9	
	1400	5	30,6	10,2	13
		10	32	10,5	
		15	33,4	8,8	
ECOevo 2 EC 23	2300	5	26,8	17	32
		10	28,7	14,6	
		15	30,6	12,3	
	2000	5	27,8	15,5	25
		10	29,6	13,4	
		15	31,4	11,2	
	1700	5	29,1	13,9	19
		10	30,7	12	
		15	32,3	10,1	
ECOevo 2 EC 30	3000	5	25,4	20,8	29
		10	27,3	17,7	
		15	29,1	14,5	
	2650	5	26,3	19,2	23
		10	28	16,3	
		15	29,8	13,4	
	2300	5	27,3	17,4	18
		10	28,9	14,8	
		15	30,5	12,2	
ECOevo 2 EC 33	3300	5	24,7	22,1	35
		10	26,7	18,8	
		15	28,6	15,4	
	2950	5	25,5	20,6	28
		10	27,4	17,5	
		15	29,2	14,4	
	2600	5	26,4	18,9	23
		10	28,2	16,1	
		15	29,9	13,2	
ECOevo 2 EC 45	4500	5	27	33,7	28
		10	28,9	29	
		15	30,8	24,3	
	4100	5	27,8	31,7	24
		10	29,5	27,3	
		15	31,3	22,9	
	3700	5	28,6	29,6	20
		10	30,2	25,5	
		15	31,8	21,3	
ECOevo 2 EC 67	6700	5	24	42,3	58
		10	26,2	37,1	
		15	28,5	31	
	6100	5	24,7	40,9	48
		10	26,8	35	
		15	29	29,3	
	5500	5	25,5	38,3	41
		10	27,6	32,9	
		15	29,6	27,6	

Condensing temperature 50°C



COMPLEMENTARY MODULES

DIRECT EXPANSION MODULE

Cooling Mode Model	Airflow (m³/h)	Air inlet temperature (°C)	Air outlet temperature (°C)	Cooling capacity (kW)	Air pressure drop (Pa)
ECOEV0 2 EC 6	600	31	17,8	4,2	43
		28	16	3,4	
		25	14,4	2,6	
	500	31	17,2	3,7	32
		28	15,5	3	
		25	13,9	2,3	
	400	31	16,5	3,1	23
		28	14,9	2,5	
		25	13,3	2	
ECOEV0 2 EC 13	1000	31	19,4	5,8	96
		28	17,5	4,7	
		25	15,6	3,7	
	800	31	18,7	5	68
		28	16,9	4	
		25	15,1	3,2	
	600	31	17,8	4,1	43
		28	16,1	3,3	
		25	14,4	2,6	
ECOEV0 2 EC 19	1900	31	18,2	12,6	60
		28	16,4	10,2	
		25	14,6	8	
	1650	31	17,7	11,5	48
		28	16	9,3	
		25	14,3	7,3	
	1400	31	17,2	10,3	37
		28	15,5	8,3	
		25	13,9	6,5	
ECOEV0 2 EC 23	2300	31	18,8	14,3	81
		28	16,9	11,5	
		25	15,2	9	
	2000	31	18,4	13	65
		28	16,5	10,5	
		25	14,8	8,3	
	1700	31	17,8	11,7	50
		28	16,1	9,5	
		25	14,3	7,4	
ECOEV0 2 EC 30	3000	31	18,9	18,5	75
		28	17	14,9	
		25	15,2	11,6	
	2650	31	18,5	17	61
		28	16,6	13,8	
		25	14,9	10,7	
	2300	31	18	15,5	49
		28	16,2	12,5	
		25	14,5	9,8	
ECOEV0 2 EC 33	3300	31	19,2	19,6	87
		28	17,3	15,7	
		25	15,5	12,1	
	2950	31	18,8	18,3	73
		28	16,9	14,8	
		25	15,2	11,4	
	2600	31	18,4	16,8	60
		28	16,6	13,6	
		25	14,9	10,5	
ECOEV0 2 EC 45	4500	31	18,7	28,4	72
		28	16,8	22,8	
		25	15,1	17,7	
	4100	31	18,4	26,7	63
		28	16,5	21,6	
		25	14,8	16,8	
	3700	31	18	25,1	53
		28	16,2	20,2	
		25	14,6	15,7	
ECOEV0 2 EC 67	6700	31	19,1	31,1	91
		28	17,3	24,8	
		25	14,5	16,3	
	6100	31	18,9	26,9	80
		28	17,1	23,7	
		25	15,3	18,4	
	5500	31	18,6	28	70
		28	16,8	22,6	
		25	17,4	17,4	

Evaporation temperature 5°C; Air humidity 50 %

COMPLEMENTARY MODULES

ELECTRIC HEATING MODULE

Model	Airflow (m ³ /h)	Air inlet temperature (°C)	Air outlet temperature (°C)	Heating capacity (kW)	Air pressure drop (Pa)
ECOevo 2 EC 6	600	5	19,8	3	1
		10	24,8		
		15	29,8		
	500	5	22,8		
		10	27,8		
		15	32,8		
	400	5	27,2		
		10	32,2		
		15	37,2		
ECOevo 2 EC 13	1300	5	18,7	6	2
		10	23,7		
		15	28,7		
	1100	5	21,2		
		10	26,2		
		15	31,2		
	900	5	24,8		
		10	29,8		
		15	34,8		
ECOevo 2 EC 19	1900	5	23,2	12	2
		10	28,2		
		15	33,2		
	1650	5	26,6		
		10	31,6		
		15	36,6		
	1400	5	30,4		
		10	35,4		
		15	40,4		
ECOevo 2 EC 23	2300	5	20,5	12	2
		10	25,5		
		15	30,5		
	2000	5	22,8		
		10	27,8		
		15	32,8		
	1700	5	25,9		
		10	30,9		
		15	35,9		
ECOevo 2 EC 30	3000	5	22,8	18	2
		10	27,8		
		15	32,8		
	2650	5	25,1		
		10	30,1		
		15	35,1		
	2300	5	28,2		
		10	33,2		
		15	38,2		
ECOevo 2 EC 33	3300	5	21,2	18	2
		10	26,2		
		15	31,2		
	2950	5	23,1		
		10	28,1		
		15	33,1		
	2600	5	25,5		
		10	30,5		
		15	35,5		
ECOevo 2 EC 45	4500	5	22,8	27	3
		10	27,8		
		15	32,8		
	4100	5	24,5		
		10	29,5		
		15	34,5		
	3700	5	26,6		
		10	31,6		
		15	36,6		
ECOevo 2 EC 67	6700	5	20,9	36	3
		10	25,9		
		15	30,9		
	6100	5	22,5		
		10	27,5		
		15	32,5		
	5500	5	24,4		
		10	29,4		
		15	34,4		



COMPLEMENTARY MODULES

ACOUSTIC ATTENUATION MODULE

Model	Airflow (m³/h)	Air pressure drop (Pa)	Acoustic attenuation - Frequency (Hz)								Total dB(A)
			63	125	250	500	1000	2000	4000	8000	
ECOEV0 2 EC 6	600	4	3	7	12	18	26	27	20	18	21
	500	2									
	400	1									
ECOEV0 2 EC 13	1300	9	3	6	11	17	24	24	19	16	21
	1100	5									
	900	2									
ECOEV0 2 EC 19	1900	8	2	5	10	15	21	20	15	12	20
	1650	6									
	1400	2									
ECOEV0 2 EC 23	2300	11	2	5	10	15	21	20	15	12	20
	2000	9									
	1700	8									
ECOEV0 2 EC 30	3000	12	2	5	10	15	21	20	15	12	20
	2650	9									
	2300	7									
ECOEV0 2 EC 33	3300	15	2	5	10	15	21	20	15	12	20
	2950	11									
	2600	9									
ECOEV0 2 EC 45	4500	15	2	5	9	14	19	17	13	10	19
	4100	14									
	3700	10									
ECOEV0 2 EC 67	6700	22	1	3	7	11	14	12	8	6	18
	6100	20									
	5500	17									

PERFORMANCE CURVES

RECOVERY EFFICIENCY CURVE

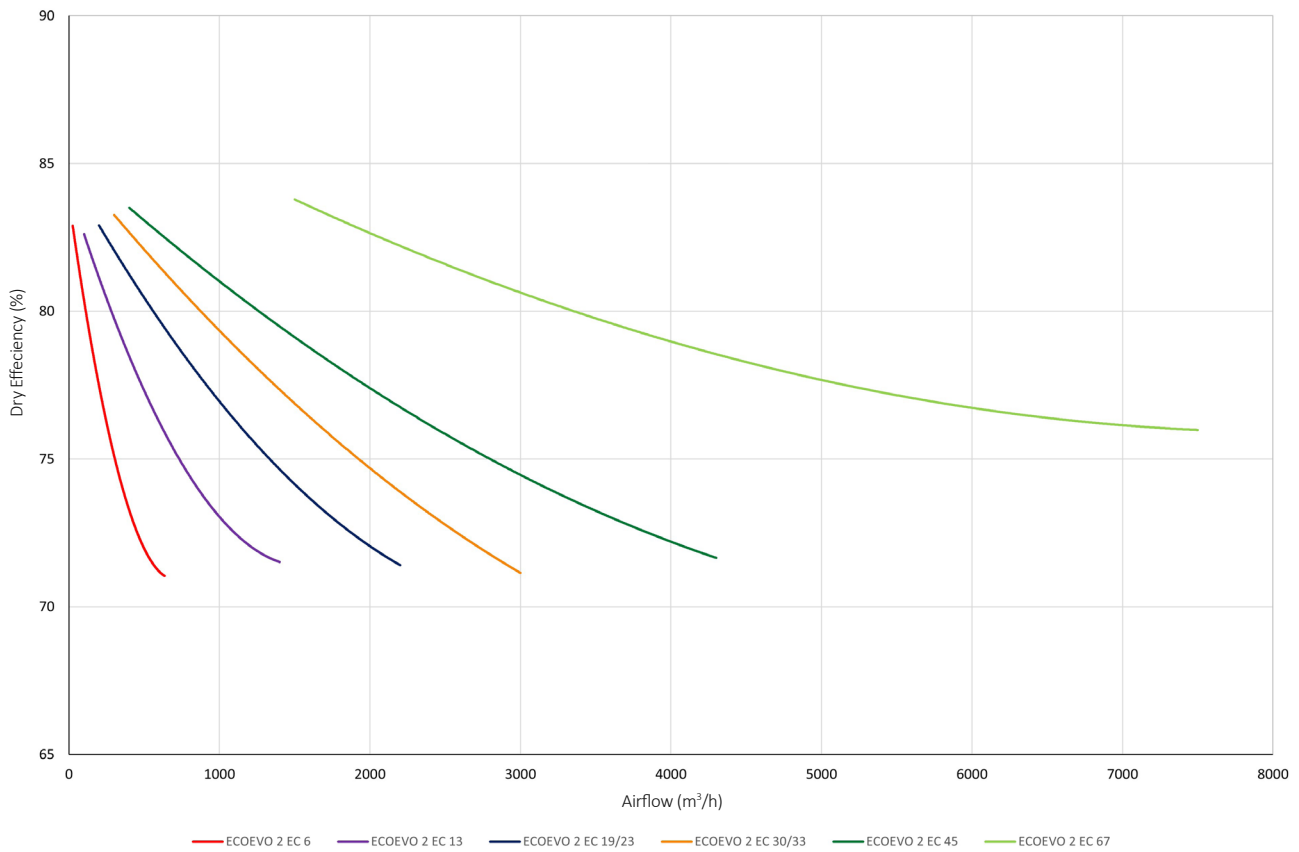

ECOEVO 2 EC ePM10 50%/M5

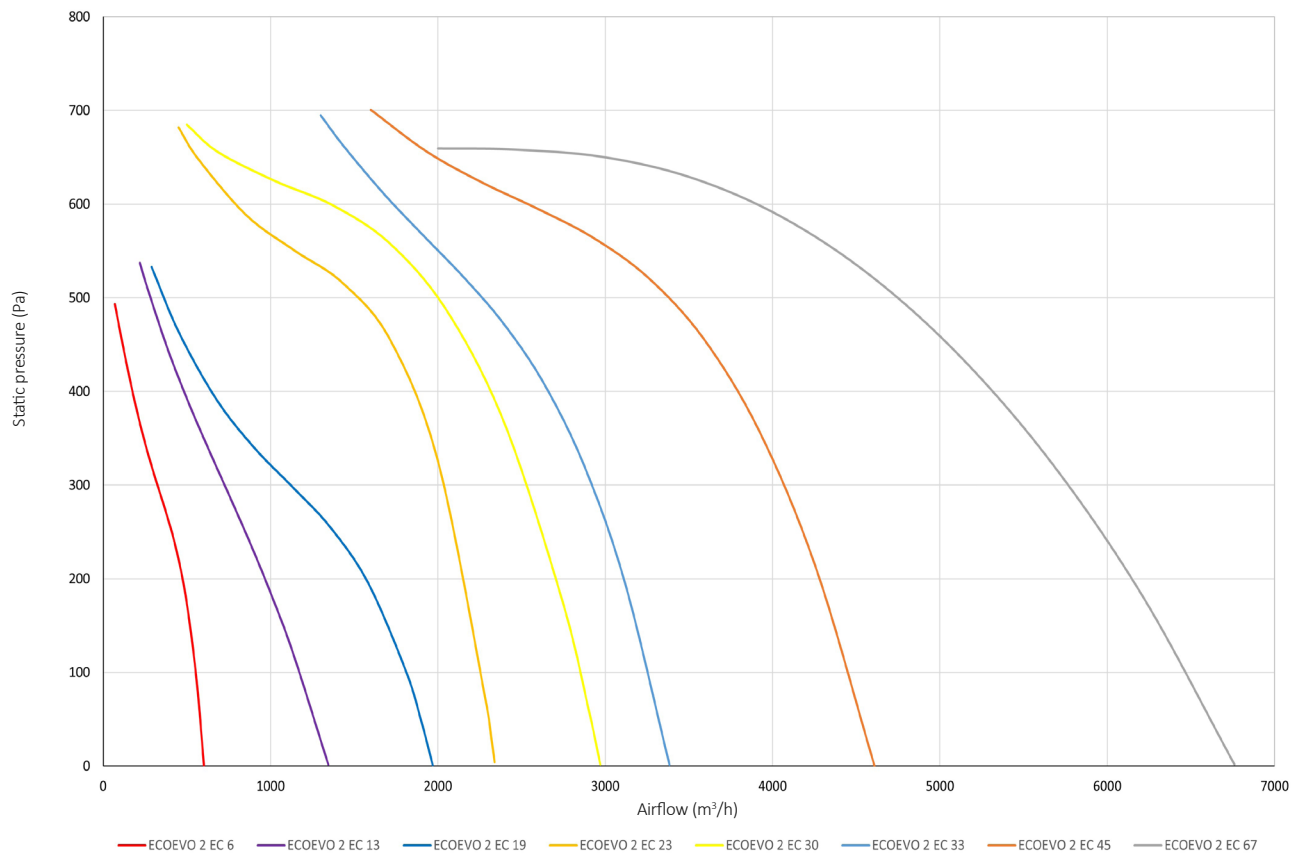



PERFORMANCE CURVES

ECOevo 2 EC ePM1 50%/F7

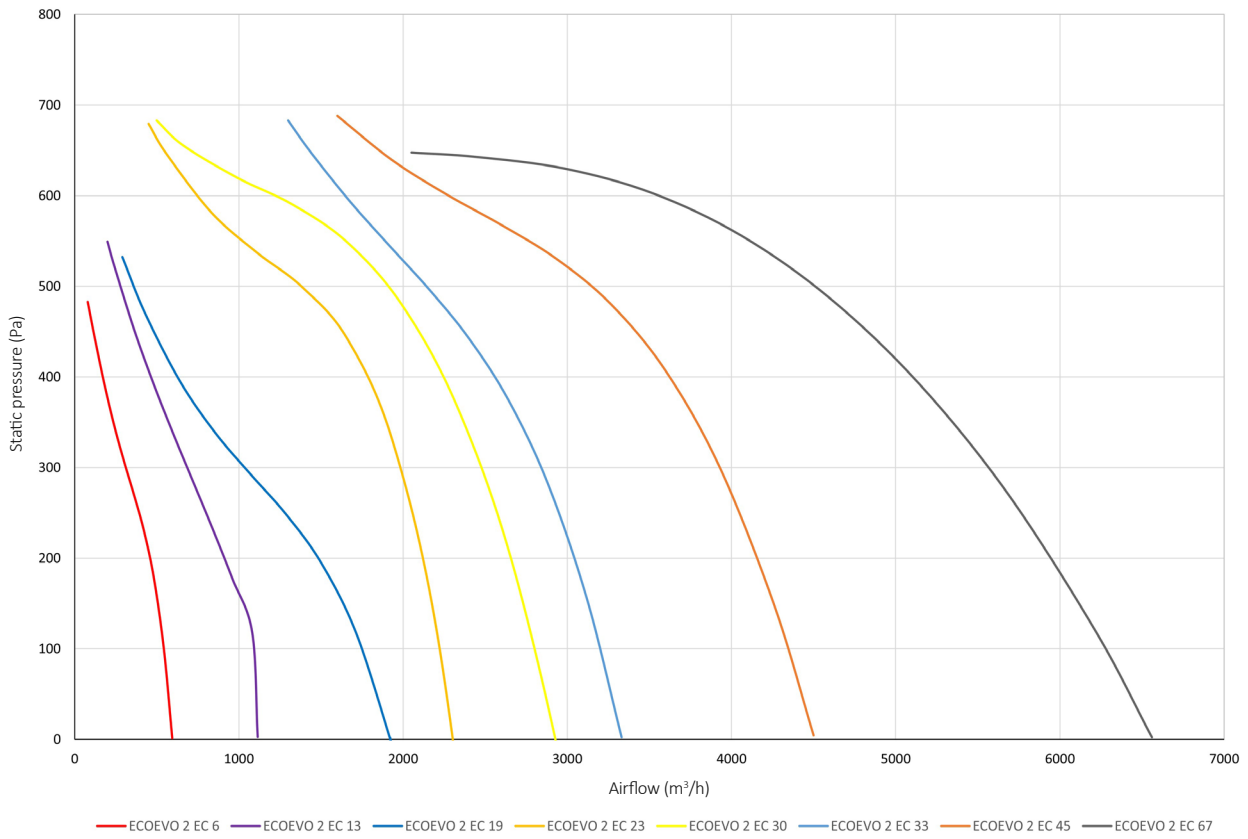

ECOevo 2 EC ePM1 80%/F9

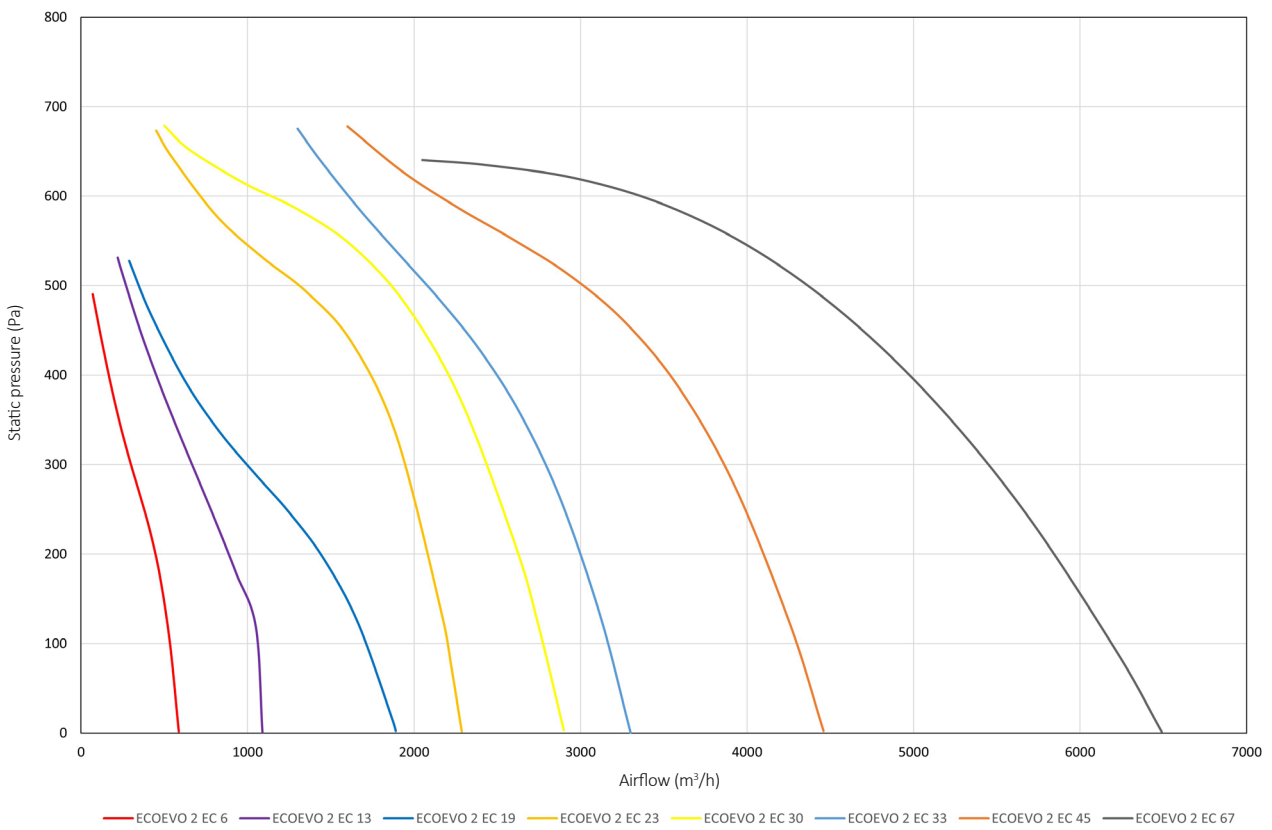

PERFORMANCE CURVES

ECOEVO 2 EC ePM10 50%/M5 + ePM1 50%/F7

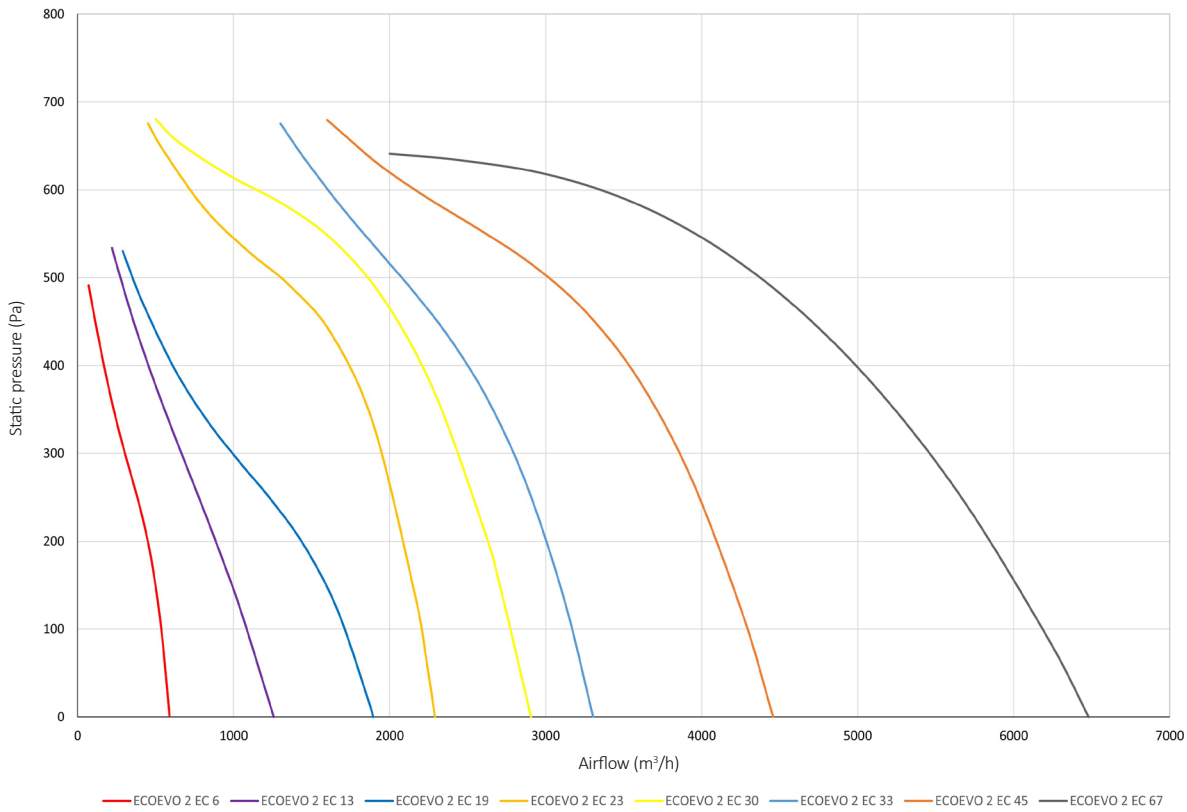

ECOEVO 2 EC ePM10 50%/M5 + ePM1 80%/F9

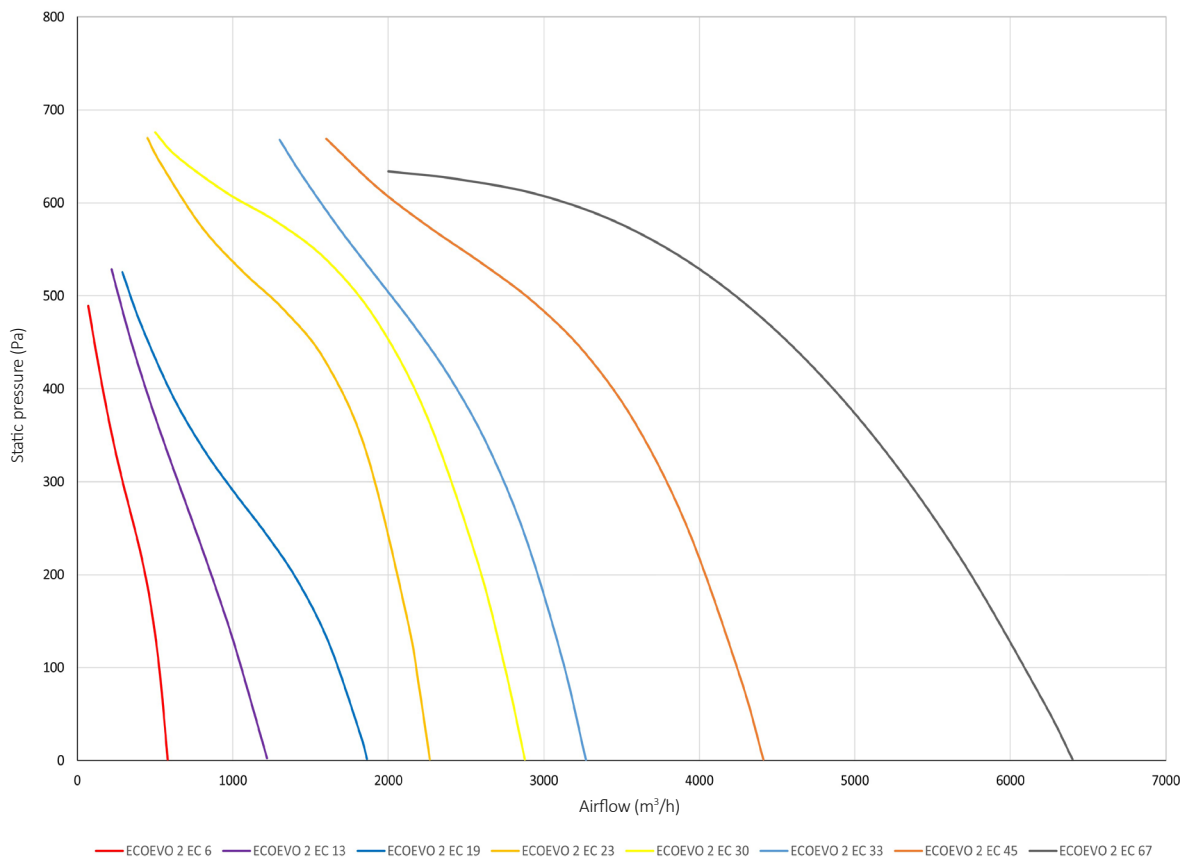



PERFORMANCE CURVES

ECOEOVO 2 EC ePM1 50%/F7 + ePM1 80%/F9

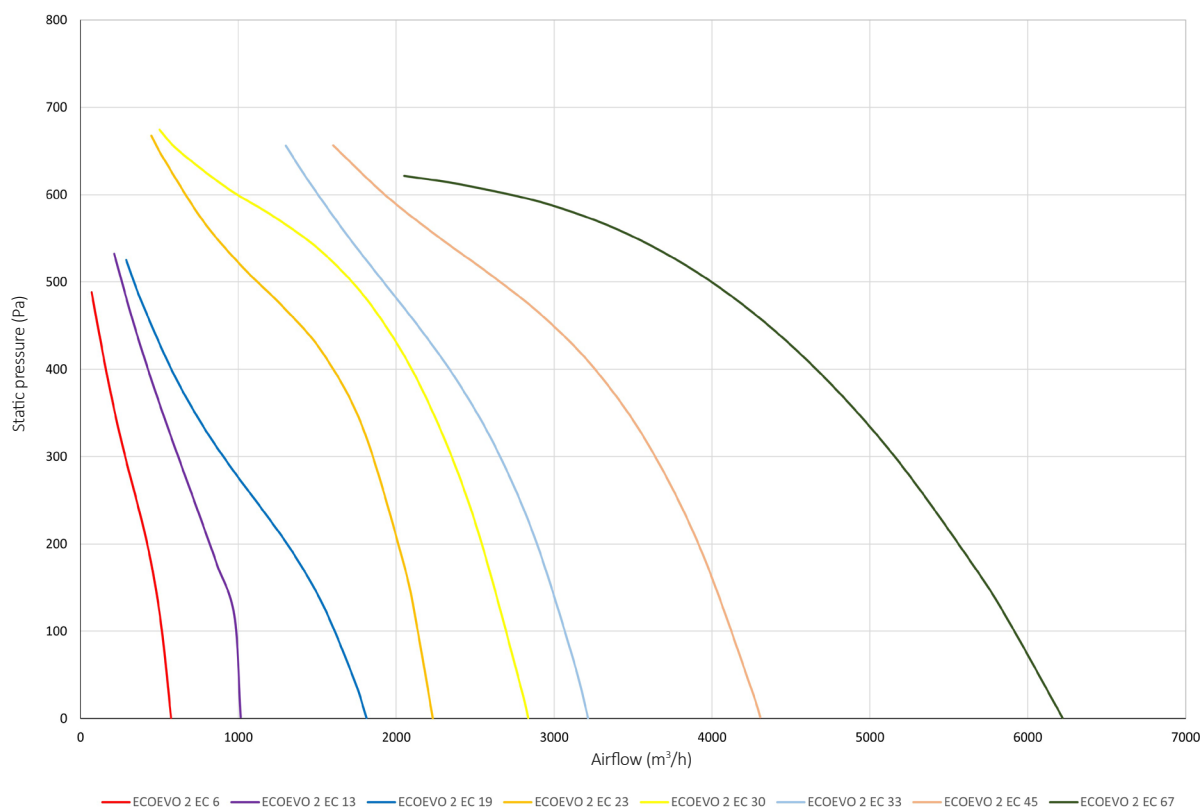

DIMENSIONS

ECOEOVO 2 EC H	6	13	19	23	30	33	45	67
A (mm)	460	500	600	600	650	650	700	900
L (mm)	900	1140	1300	1300	1550	1550	1600	1950
P (mm)	900	1140	1300	1300	1550	1550	1600	1950
ØD (mm)	200	315	315	315	315	355	355	2 X 315
E (mm)	317	299	398	398	449	429	479	699
C (mm)	405	525	605	605	730	730	755	930
H (mm)	400	440	540	540	590	590	640	840
Weight (kg)	96	151	196	206	232	240	258	443

ECOEOVO 2 EC V	6	13	19	23	30	33	45	67
A (mm)	900	1250	1400	1400	1700	1700	1700	1950
L (mm)	460	500	600	600	650	650	700	900
P (mm)	1000	1500	1650	1650	1850	1850	2000	2100
ØD (mm)	200	315	315	315	315	355	355	2 X 315
E (mm)	322	439	514	514	664	644	644	699
F (mm)	143	202	202	202	202	221	221	201
C (mm)	455	705	780	780	880	880	1005	1005
H (mm)	405	580	655	655	805	805	805	930
Weight (kg)	115	181	235	247	278	288	309	509

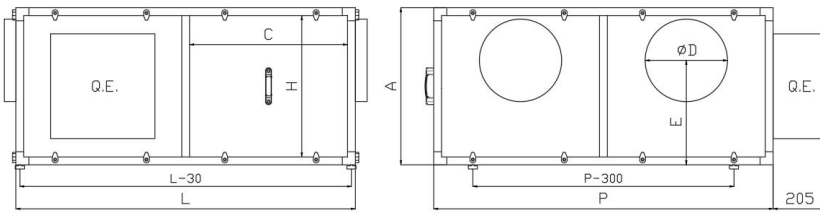
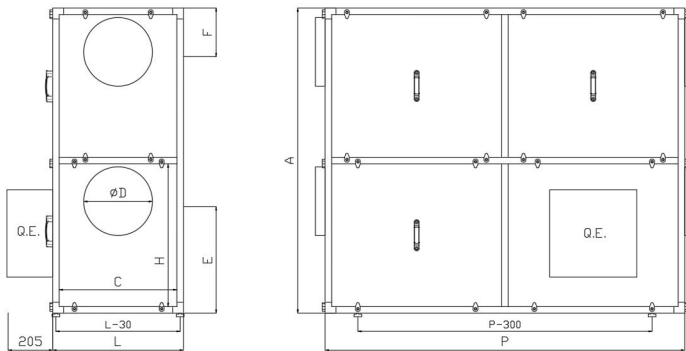
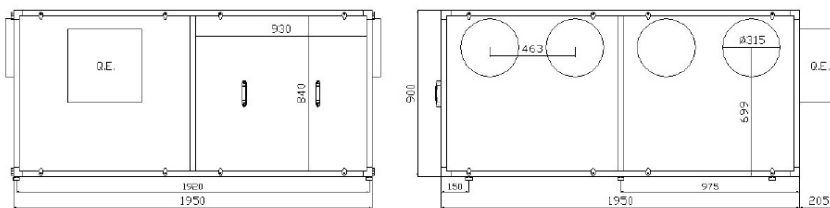
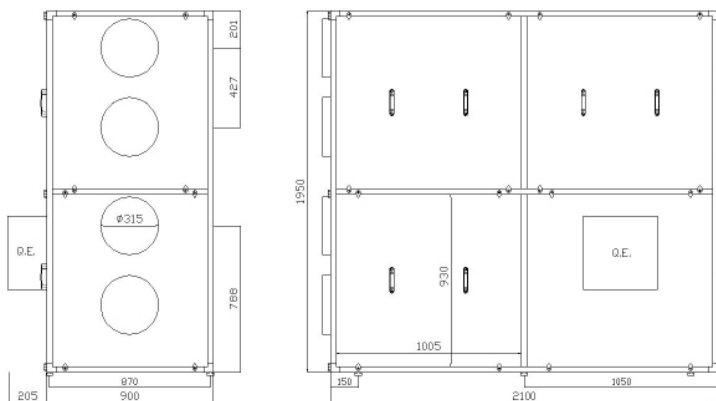
DIMENSIONS
ECO EVO 2 EC H

ECO EVO 2 EC V

ECO EVO 2 EC H SIZE 67

ECO EVO 2 EC V SIZE 67

NOTE: MAINTENANCE CLEARANCE AND UNIT ACCESS DISTANCE | 750 MM



DIMENSIONS

DIRECT EXPANSION / CHANGE OVER MODULE

MBCR/A	6	13	19	23	30	33	45	67
A (mm)	460	500	600	600	650	650	700	900
L (mm)	550	550	800	800	900	900	1050	1050
P (mm)	600	600	700	700	800	800	950	950
∅ Steam (mm)	16	16	28	28	35	35	35	35
∅ Liquid (mm)	22	22	35	35	35	35	42	42
∅ Water (pol)	3/4"	3/4"	1 1/4"	1 1/4"	1 1/2"	1 1/2"	2"	2"
Weight (kg)	38	39	28	28	32	32	35	42

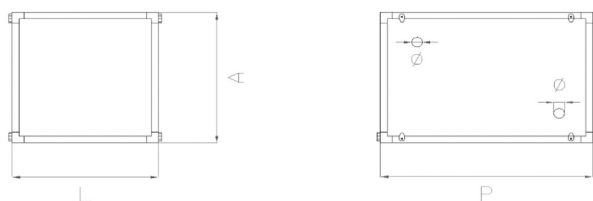

NOTE: MAINTENANCE CLEARANCE AND UNIT ACCESS UP TO SIZE 13 | 750 MM; FROM SIZE 13 | 1000 MM

WATER HEATING MODULE

MBAA	6	13	19	23	30	33	45	67
A (mm)	460	500	600	600	650	650	700	900
L (mm)	450	570	650	650	775	775	800	975
P (mm)	350	350	350	350	350	350	350	350
∅ Water (pol)	3/4"	3/4"	1 1/4"	1 1/4"	1 1/2"	1 1/2"	2"	2"
Weight (kg)	18	23	28	28	32	32	35	42

ELECTRIC HEATING MODULE

MBRE	6	13	19	23	30	33	45	67
A (mm)	460	500	600	600	650	650	700	900
L (mm)	450	570	650	650	775	775	800	975
P (mm)	350	350	350	350	350	350	350	350
Weight (kg)	17	21	29	29	30	30	34	41

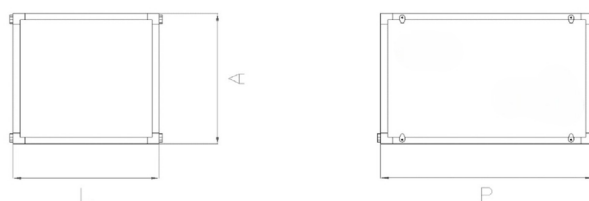

NOTE: MAINTENANCE CLEARANCE AND UNIT ACCESS UP TO SIZE 13 | 750 MM; FROM SIZE 13 | 1000 MM

DIMENSIONS
ACOUSTIC ATTENUATION MODULE

MAA	6	13	19	23	30	33	45	67
A (mm)	460	500	600	600	650	650	700	900
L (mm)	450	570	650	650	775	775	800	975
P (mm)	700	700	700	700	700	700	700	700
Weight (kg)	30	35	40	40	49	49	55	65

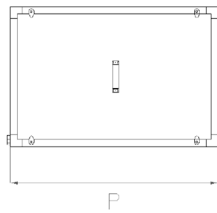
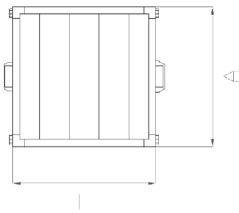

NOTE: MAINTENANCE CLEARANCE AND UNIT ACCESS UP TO SIZE 13 | 750 MM; FROM SIZE 13 | 1000 MM

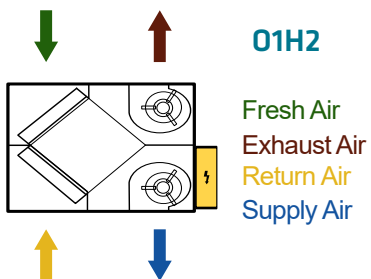
STANDARD CONFIGURATIONS HORIZONTAL MODEL



CONFIGURATIONS HORIZONTAL MODEL

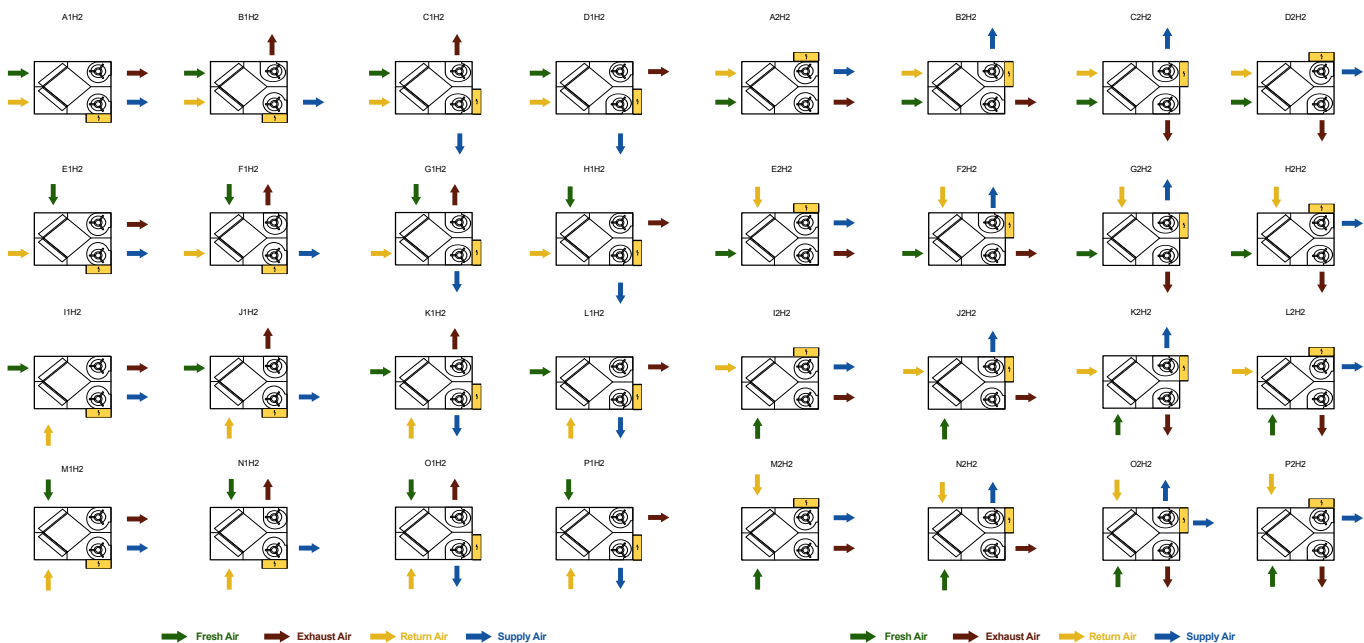

CONFIGURATIONS VERTICAL MODEL

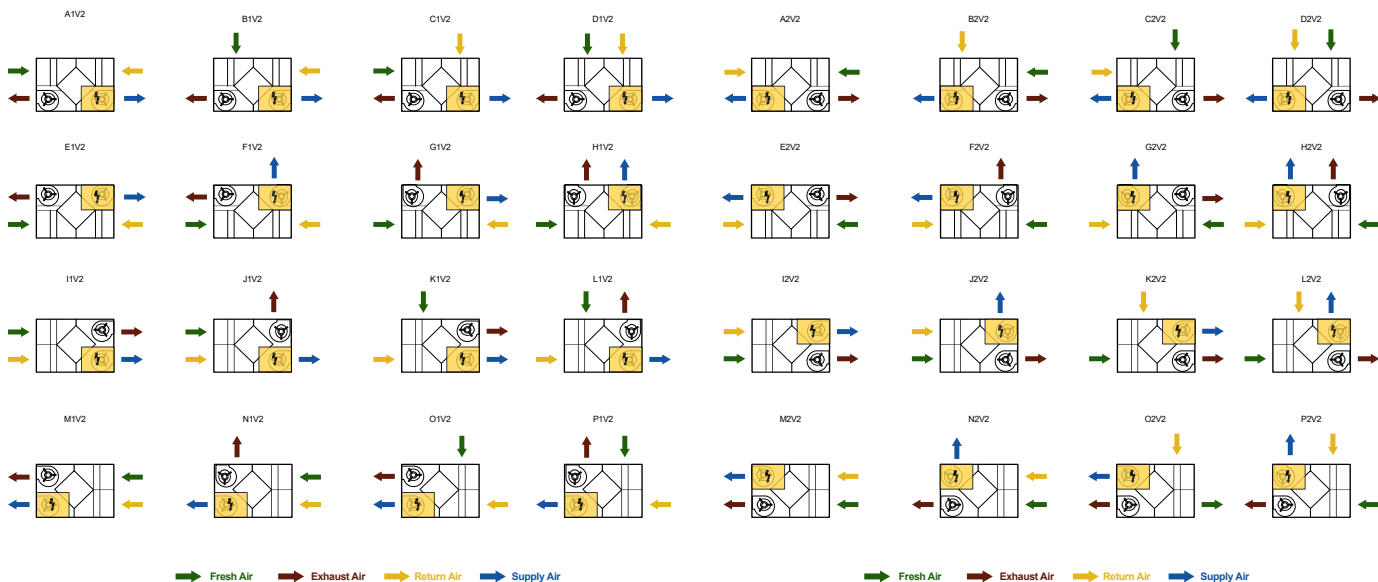

ERP VERIFICATION DOCUMENT

MANUFACTURER		ARFIT AIR CONDITIONING, S.A.							
Model		6	13	19	23	30	33	45	67
Type		UVNR UVB							
Transmission Type		Variable Speed	Variable Speed	Variable Speed	Variable Speed	Variable Speed	Variable Speed	Variable Speed	Variable Speed
Heat Recovery System Type		OTHER							
Heat Recovery Thermal Efficiency	%	73	73,1	74,7	73,6	74,3	74,2	74,2	77,2
Nominal Airflow	m ³ /s	0,147	0,306	0,481	0,531	0,676	0,686	0,994	1,594
Input Power	kW	0,159	0,32	0,52	0,78	1	1,15	1,57	2,28
SPFint	W/m ³ /s	1569,8	1551,1	1561,0	1535,3	1531,2	1526,6	1484,9	1481,2
Frontal Velocity	m/s	1,20	1,70	1,72	1,90	1,68	1,70	2,26	2,45
Nominal External Pressure	Pa	103	108	110	344	321	425	411	285
Reduction in Internal Pressure (Ventilation)	Pa	346	366	338	411	374	381	409	327
Static Efficiency of Fans	%	43,0	45,2	41,4	51,3	47,0	48,0	52,0	40,8
Maximum Declared Internal/External Leakage Rate	%	4,2/5,3	3,4/4,3	3,4/4,1	3,8/3,9	4,1/3,8	4,1/3,8	4,2/3,8	4,2/3,8
Filter Classification		F7/M5							
Description: Visual notice regarding filters		The filters warning is displayed on the unit's control system, either via a warning light or on-screen message, depending on the control system used. It is of the utmost importance to replace the filters regularly to improve the unit's performance and energy efficiency.							
Sound Power Level (Lwa)	dB(A)	58	58	63	61	68	66	66	68
Website		www.arfit.pt							



ECOevo 2 AC

[INDEX](#)

DESCRIPTION

Industrial heat recovery unit, ECOevo 2 AC model, sound-insulated equipment, for indoor or outdoor installation, with removable side panels for easy internal access, available with different accessories and configurations. Electrical control panel equipped with isolating switch.

Modular structure in extruded aluminium profile according to DIN 17615 with 30 mm thickness and reinforced nylon corners. Double-wall panels with 25 mm thickness, with outer face in Magnelis steel with corrosion class C5, inner face in galvanized steel sheet according to EN 10192. The intermediate insulation of the panels is filled with self-extinguishing polystyrene boards 25 mm thick, with a density of 30 kg/m³, providing high resistance to different mechanical stresses.

Available in 5 sizes, horizontal or vertical version and Smart or Smart CO₂ control.



Plug & Play



2 Levels of Filtration



Controlled unit



Structure Double-panel



25 mm panel

HEAT RECOVERY

STANDARDS AND CERTIFICATIONS



ADVANTAGES

- Plug & Play monoblock unit.
- Corrosion class C5.
- Multiple configurations.
- 3-way valve and actuator included.

ACCESSORIES

- ePM10 50% / M5 filter
- ePM1 50% / F7 filter
- ePM1 80% / F9 filter
- Protection for rain
- Rain Roof
- Constant airflow control
- CO₂ Control

COMPONENTS

FAN

Double-inlet centrifugal fans with direct drive, high-efficiency forward-curved impeller, statically and dynamically balanced. Driven directly by single-speed AC electric motors with permanent capacitor, built-in automatic reset thermal protection, insulation class B or F, with mechanical protection IP44 to IP55. Driven by a voltage regulator.

FILTERS

Filters of class ePM10 50% / M5, ePM1 50% / F7 or ePM1 80% / F9 according to EN 779 / ISO 16890. Filters are mounted in parallel in rails designed to maintain bypass leakage values within F9 class according to EN 1886.

HEAT EXCHANGER

High-efficiency parallel-flow heat exchangers with bypass, allowing sensible heat recovery from exhaust air to supply air with efficiencies up to 80% (Eurovent certified). Constructed with stamped aluminium plates with double-fold edges ensuring airtightness up to 1500 Pa.

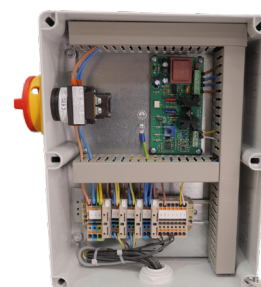

CHARACTERISTICS

ECO EVO 2 AC	6	12	20	26	32
Motor Power (kW)	2 x 0,29	2 x 0,35	2 x 0,59	2 x 0,59	2 x 0,59
Power Supply (V F Hz)	230 1 50				
IMAX (A)	2,66	5,5	9,1	9,1	9,1
Sound Pressure (dB(A)) **	39	33	37	43	52

** Sound pressure level at 4 m, measured in open field according to ISO 3744

PERFORMANCE CURVES

RECOVERY EFFICIENCY CURVE

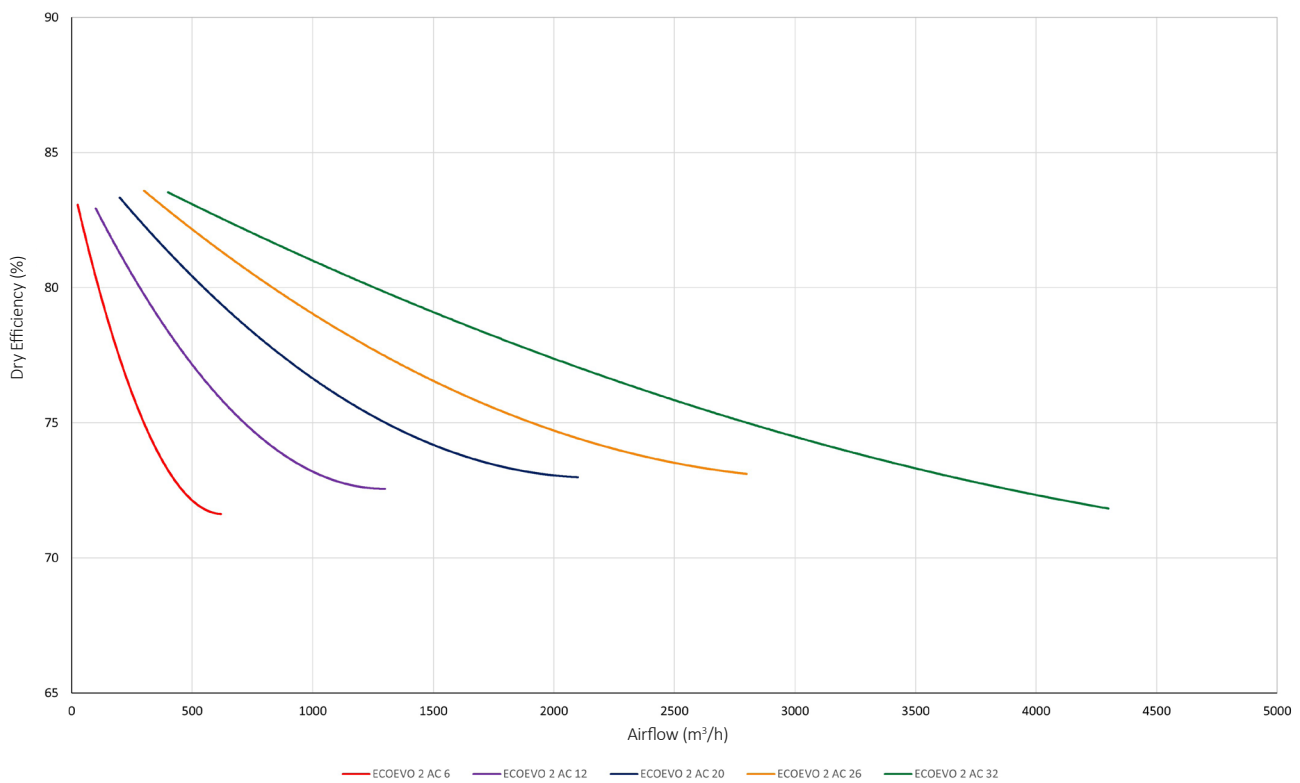



PERFORMANCE CURVES

HEAT RECOVERY

ECOEOVO 2 AC ePM10 50%/M5

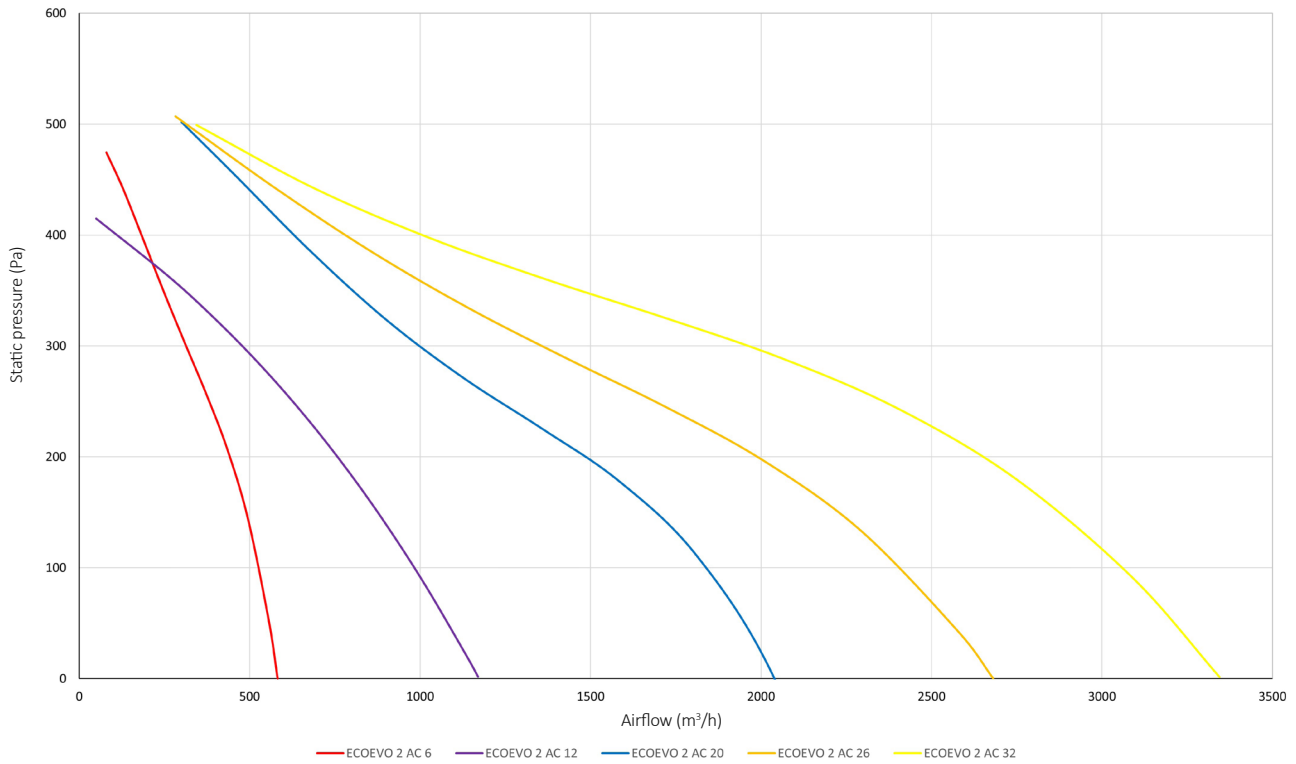

ECOEOVO 2 AC ePM1 50%/F7

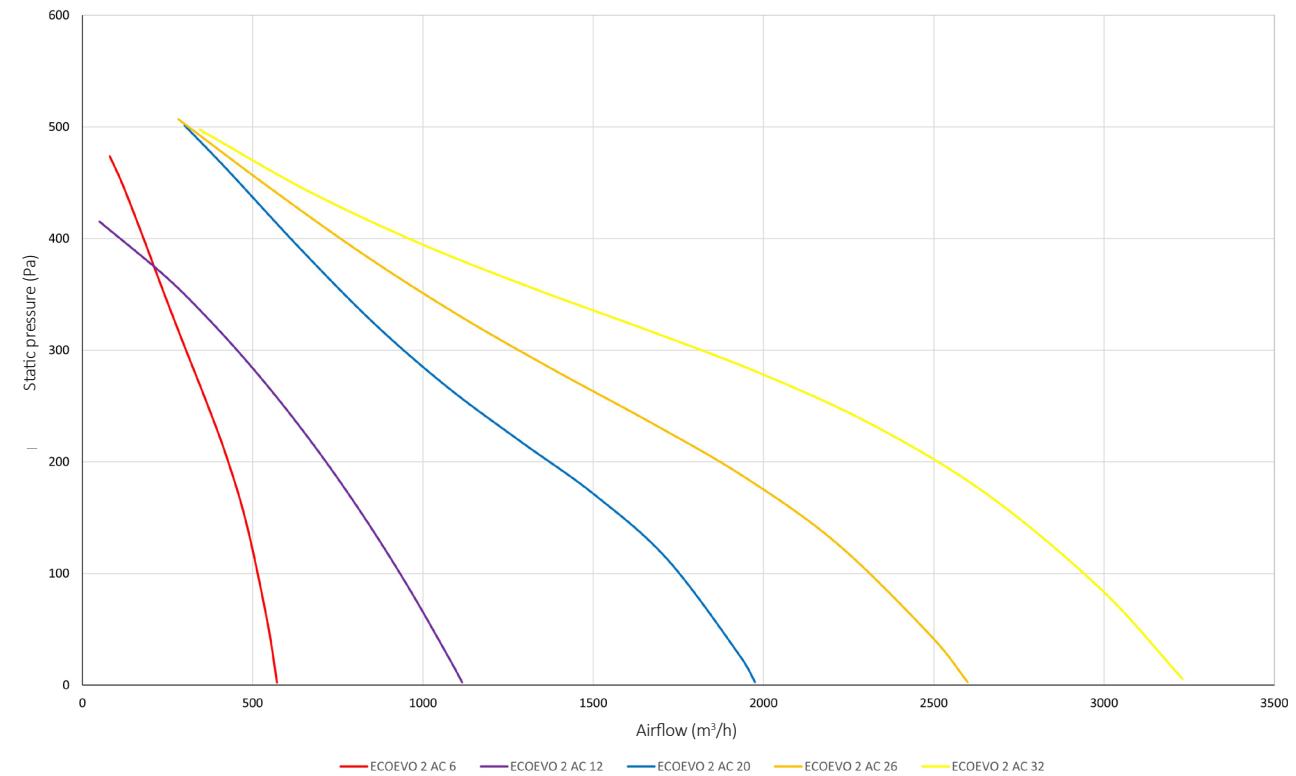

PERFORMANCE CURVES

ECOEVO 2 AC ePM1 80%/F9

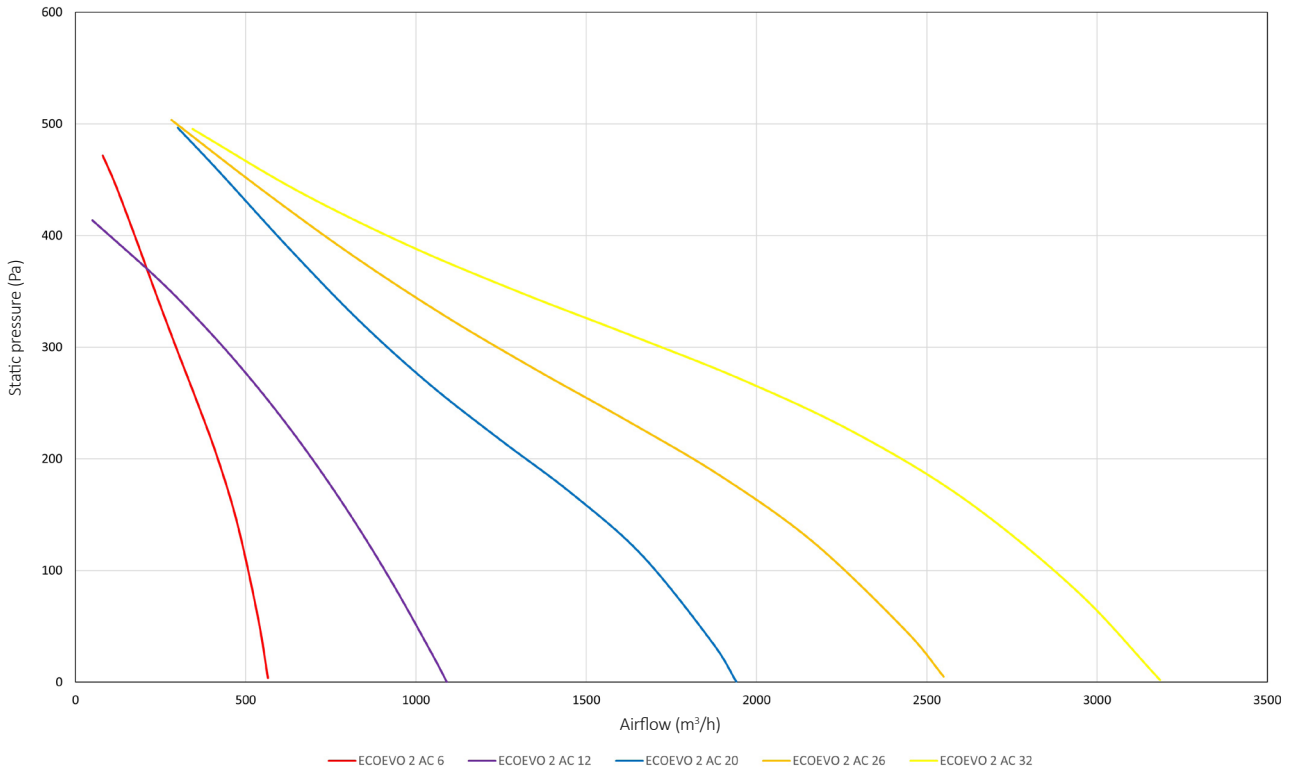

ECOEVO 2 AC ePM10 50%/M5 + ePM1 50%/F7

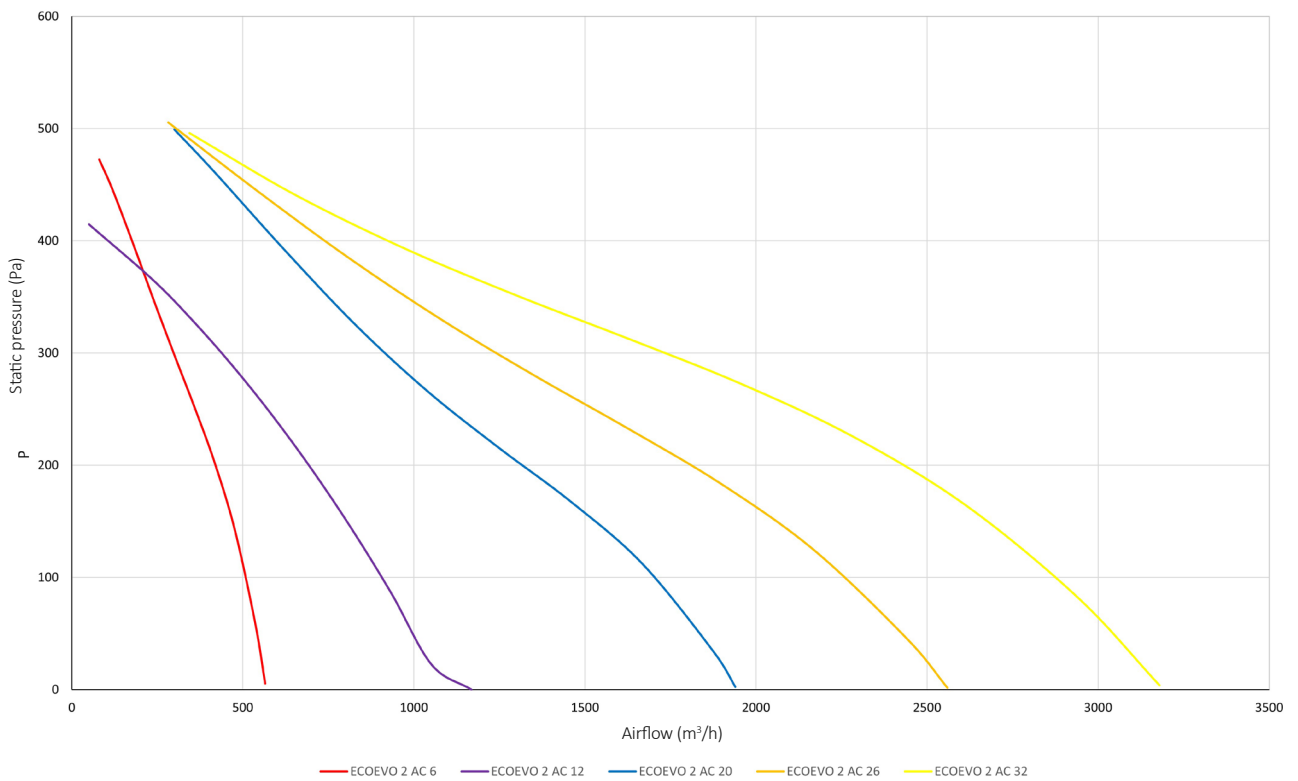



PERFORMANCE CURVES

ECOEOVO 2 AC ePM10 50%/M5 + ePM1 80%/F9

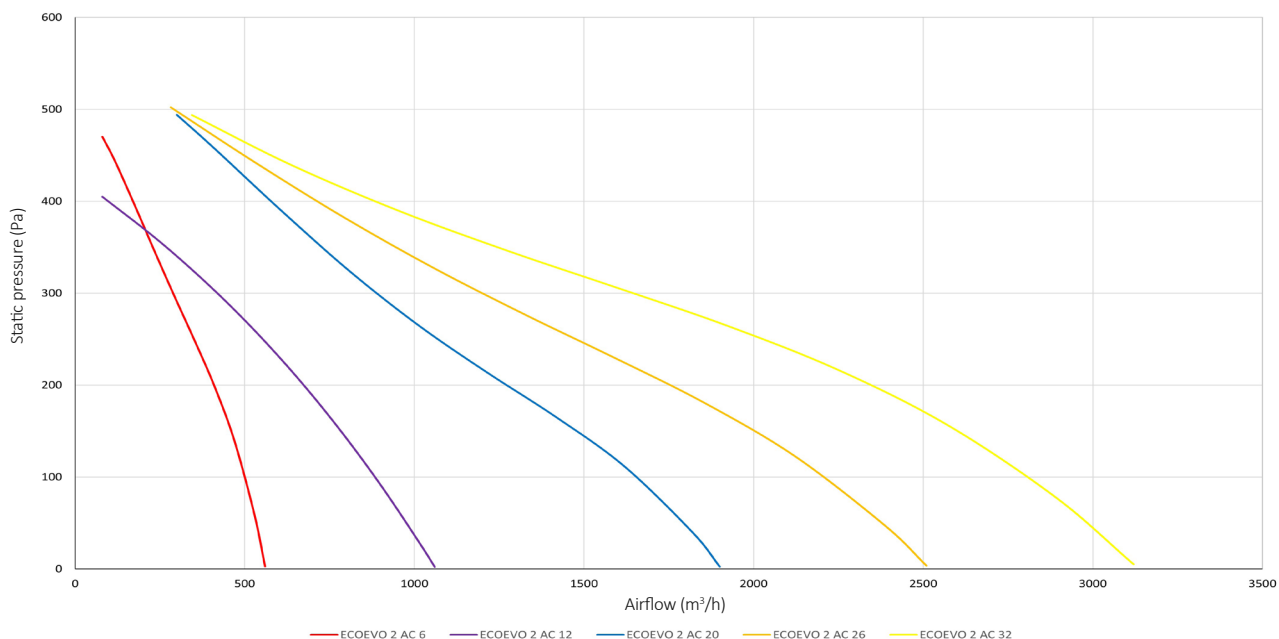

ECOEOVO 2 AC ePM1 50%/F7 + ePM1 80%/F9

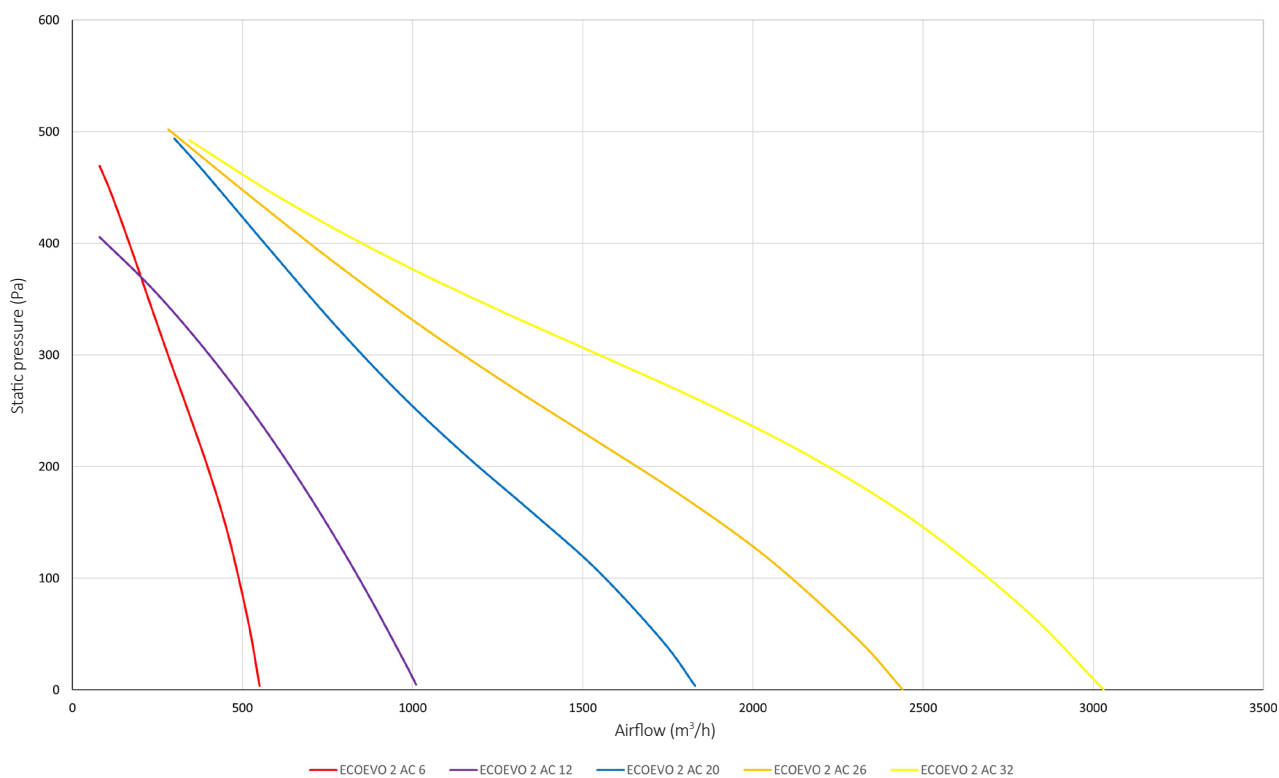

DIMENSIONS

ECOEVO 2 AC H	6	12	20	26	32
A (mm)	460	500	600	650	700
L (mm)	900	1140	1300	1550	1600
P (mm)	900	1140	1300	1550	1600
ØD (mm)	200	315	355	355	355
E (mm)	317	299	379	429	479
C (mm)	405	525	605	730	755
H (mm)	400	440	540	590	640
Weight (kg)	77	130	181	224	247
ECOEVO 2 AC V	6	12	20	26	32
A (mm)	900	1250	1400	1700	1700
L (mm)	460	500	600	650	700
P (mm)	1000	1500	1650	1850	2000
ØD (mm)	200	315	355	355	355
E (mm)	322	439	494	644	644
F (mm)	143	202	221	221	221
C (mm)	455	705	780	880	1005
H (mm)	405	580	655	805	805
Weight (kg)	92	156	217	268	296

ECOEVO 2 AC H

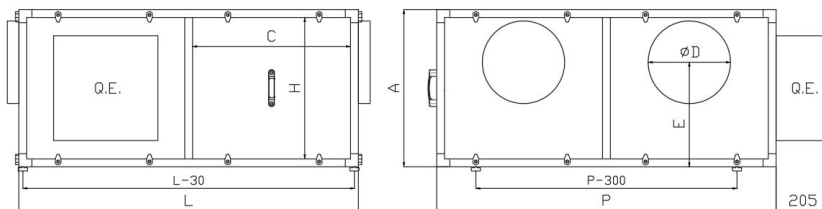

ECOEVO 2 AC V

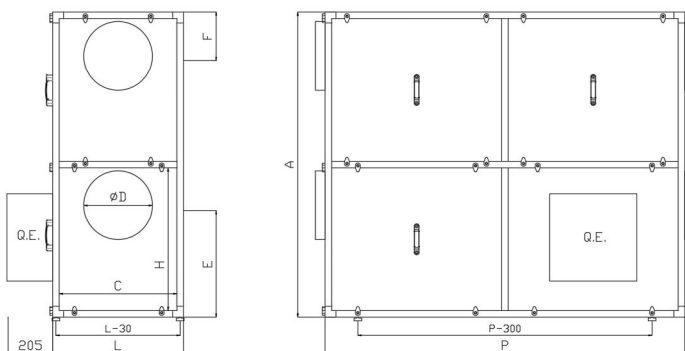

NOTE: MAINTENANCE CLEARANCE AND UNIT ACCESS DISTANCE | 750 MM



STANDARD CONFIGURATIONS HORIZONTAL MODEL

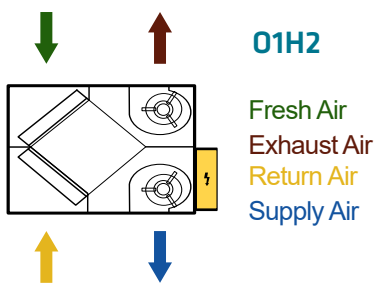

HEAT RECOVERY

CONFIGURATIONS HORIZONTAL MODEL

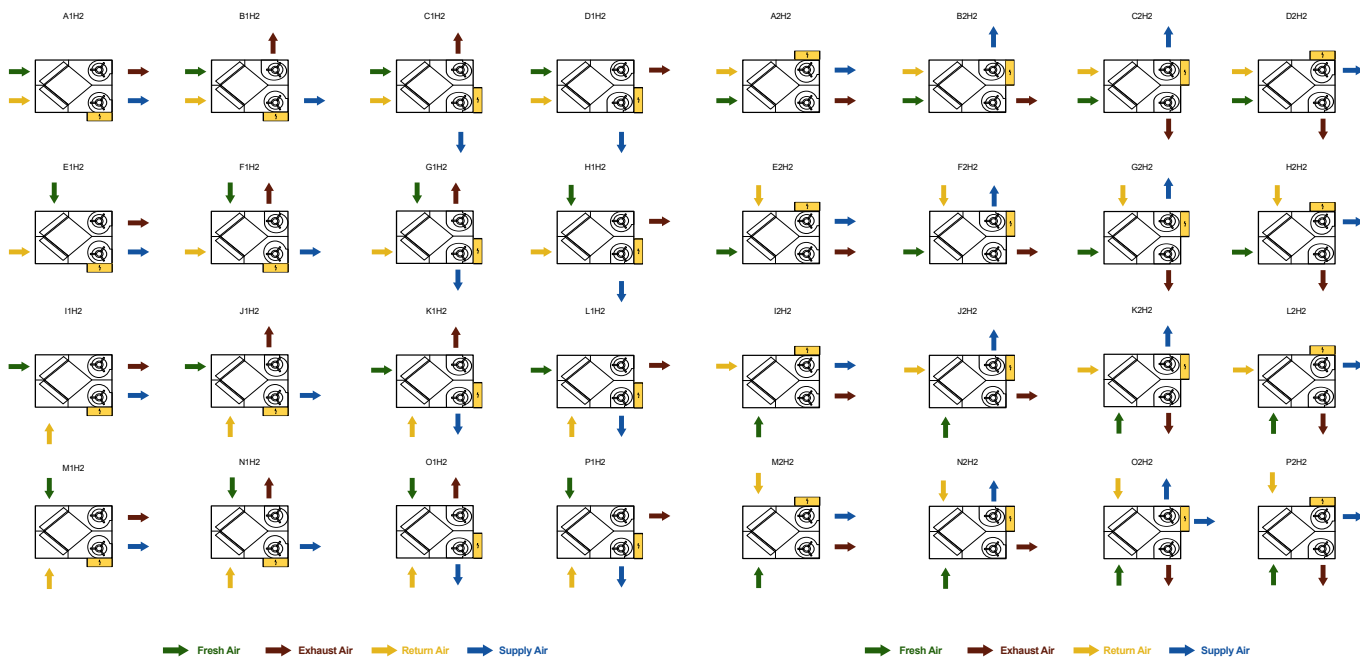

CONFIGURATIONS VERTICAL MODEL

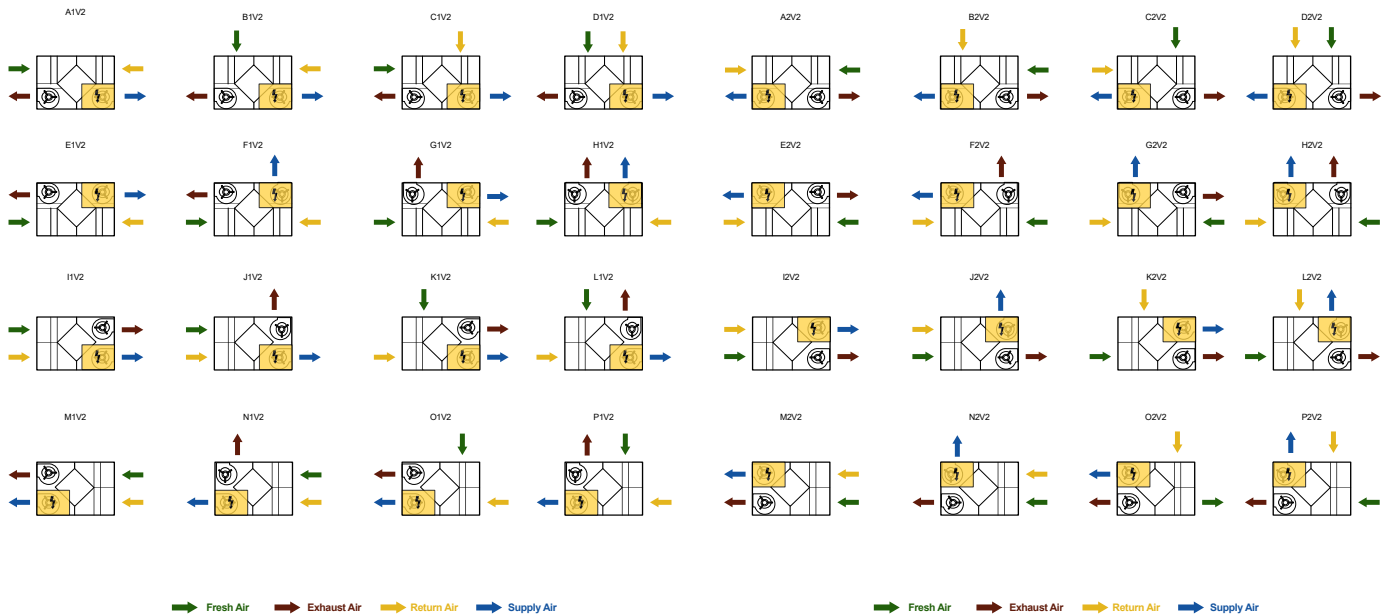

ERP VERIFICATION DOCUMENT

MANUFACTURER		ARFIT AIR CONDITIONING, S.A.				
Model		6	12	20	26	32
Type		UVNR UVB				
Transmission Type		Variable Speed	Variable Speed	Variable Speed	Variable Speed	Variable Speed
Heat Recovery System Type		OTHER				
Heat Recovery Thermal Efficiency	%	73	74,5	74,9	74,8	75,2
Nominal Airflow	m ³ /s	0,125	0,228	0,408	0,639	0,842
Input Power	kW	0,17	0,32	0,57	0,67	0,85
SPFint	W m ³ /s	1579	1602,8	1594,3	1538,1	1536,9
Frontal Velocity	m/s	1,02	1,39	1,57	1,69	1,91
Nominal External Pressure	Pa	179	154	178	105	74
Decrease in internal pressure (Ventilation)	Pa	264	228	266	338	308
Static Efficiency of Fans	%	32,6	27,2	31,9	42,2	37,8
Maximum Declared Internal/External Leakage Rate	%	4,2/5,3	3,4/4,3	3,4/4,1	3,8/3,9	4,1/3,8
Filter Classification		F7/M5				
Description: Visual notice regarding filters		The filters warning is displayed on the unit's control system, either via a warning light or on-screen message, depending on the control system used. It is of the utmost importance to replace the filters regularly to improve the unit's performance and energy efficiency, e energy efficiency da unidade."				
Sound Power Level (Lwa)	dB(A)	67	55	56	56	71
Website		www.arfit.pt				



ECOevo 3 SLIM



Plug & Play

EC
Technology

Controlled unit

2 Levels of
filtration25 mm
panel

DESCRIPTION

Low-profile heat recovery unit, ECOevo 3 SLIM model, sound-insulated, for indoor or outdoor installation, with removable side panels for easy maintenance access. Incorporates integrated electrical panel with isolating switch for enhanced safety and ease of operation.

Robust construction with 25 mm double-wall panels, ensuring good thermal and acoustic insulation. The outer face in Magnelis steel with corrosion class C5 ensures high durability even in demanding environments.

Available in 3 sizes, with airflow rates between 1100 and 2600 m³/h, adapting to different ventilation applications. Equipped with EC Plug Fans and heat exchanger with efficiency up to 90%, allowing high energy efficiency and reduced consumption in HVAC systems.

STANDARDS AND CERTIFICATIONS



ADVANTAGES

- Compact low-profile modular monoblock Plug & Play unit.
- Double panels with 25 mm insulation.
- Corrosion class C5.
- Low-consumption electronically commutated motor.
- Possible integration of Be.On module with cloud connection and Be.Smart monitoring.
- 3-way valve and actuator included.
- Integrated electrical panel.

ACCESSORIES

- ePM10 50%/M5 filter
- ePM1 50%/F7 filter
- ePM1 80%/F9 filter
- Protection for rain
- Rain roof
- Heating / cooling coil modules
- Acoustic attenuation module
- Constant airflow control
- CO₂ Control

COMPONENTS

FILTERS

The filtration system includes two filters with filtration classes ePM10 50% (M5), ePM1 50% (F7) or ePM1 80% (F9), in accordance with EN 779 / ISO 16890.

The parallel mounting system uses dedicated rails that ensure airtightness, maintaining bypass leakage within class F9 (EN 1886).

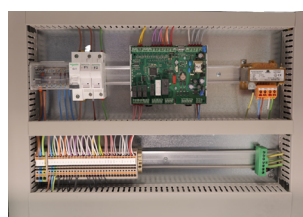

FAN

EC brushless Plug Fan with backward-curved blades, compact design and high available pressures. The aerodynamic rotor geometry, balanced according to ISO 1940 G2.5 and with vibration levels in accordance with AMCA 204, combined with EC motor with insulation class F and IP55 protection, ensures high capacity, efficiency and performance (IE5), even at high resistance levels.

HEAT EXCHANGER

Parallel-flow heat exchangers. Allows recovery of up to 80% of sensible heat from exhaust air to supply air, with efficiency certified by Eurovent. The aluminium plate design with double-fold joints ensures structural integrity and airtightness up to 1500 Pa.

WATER HEATING MODULE

Water heating coil composed of copper tubes with aluminium fins, mechanically expanded to ensure maximum thermal contact. With steel or copper headers and galvanized steel structure, all units are subject to strict quality control, with tightness and integrity tested at 32 bar in factory.

CHANGE OVER MODULE

Water coil allowing both heating and cooling with the same coil. Composed of copper tubes, aluminium fins mechanically expanded, copper headers and galvanized steel structure. Tightness and integrity are rigorously tested at 32 bar. Module equipped with stainless steel condensate tray. Includes 3-way valve and actuator.

DIRECT EXPANSION MODULE

Direct expansion coil for R32 refrigerant. Composed of copper tubes, aluminium fins mechanically expanded, copper headers and galvanized steel structure. Factory tested at 60 bar. Equipped with stainless steel condensate tray.

ELECTRIC HEATING MODULE

Electric finned heating elements in 8 mm diameter steel tube with 25 x 50 mm fins of the same material, with quick-fix screw and M4 threaded terminals. Designed for air heating applications. Mounted in frame and placed on rails for easy removal.

ACOUSTIC ATTENUATION MODULE

Baffles made of mineral wool, with air-contact surface in non-fragmenting material protected by mesh or micro-perforated sheet, with galvanized steel frame and IP55 mechanical protection.

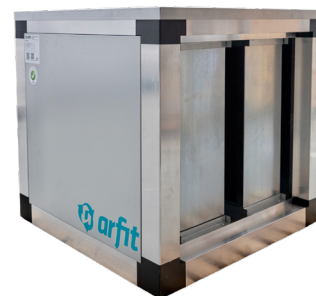
CHARACTERISTICS

ECOevo 3 SLIM	11	21	26
Motor Power (kW)	2 x 0,2	2 x 0,5	2 x 0,8
Rotational Speed (rpm)	3000	3080	3600
Power Supply (V F Hz)	230 1 50		
IMAX (A)	2,3	4,5	7,1
Sound Pressure (dB(A)) *	49	44	50

* Sound pressure level at 4 m, measured in open field in accordance with ISO 3744



BATTERY MODULES

WATER HEATING MODULE

Model	Airflow (m³/h)	Air inlet temperature (°C)	Air outlet temperature (°C)	Heating capacity (kW)	Air pressure drop (Pa)	Water flow rate (l/s)	Water pressure drop (kPa)
ECOEV0 3 SLIM 11	966	5	34	9	49,2	0,12	9,5
		10	36	9	50,0	0,11	8,2
		15	39	8	50,9	0,10	7,0
	827	5	35	9	37,3	0,10	7,9
		10	38	8	37,9	0,10	6,8
		15	40	7	38,6	0,09	5,8
		5	37	8	27,0	0,09	6,4
		10	40	7	27,5	0,09	5,5
		15	42	6	27,9	0,08	4,7
ECOEV0 3 SLIM 21	1863	5	34	18	49,1	0,22	11,9
		10	37	17	49,5	0,21	10,3
		15	39	15	50,0	0,19	9,0
	1597	5	35	17	39,8	0,20	10,0
		10	38	15	40,2	0,19	8,9
		15	41	14	40,5	0,17	8,0
		5	37	15	31,1	0,18	8,5
		10	40	14	31,3	0,17	7,7
		15	42	12	31,6	0,15	6,9
ECOEV0 3 SLIM 26	2273	5	34	23	49,1	0,28	20,3
		10	37	21	49,5	0,26	17,5
		15	39	19	50,0	0,23	14,9
	1948	5	36	20	39,8	0,25	16,9
		10	38	19	40,2	0,23	14,6
		15	41	17	40,6	0,21	12,5
		5	38	18	31,1	0,22	13,6
		10	40	17	31,4	0,20	11,8
		15	43	15	31,7	0,19	10,1

Airflow at velocities: 3.5; 3.0; 2.5 m/s

Water temperature: 80°C / 60°C

RH: 80%

CHANGE OVER MODULE

Heating mode Model	Airflow (m³/h)	Air inlet temperature (°C)	Air outlet temperature (°C)	Heating capacity (kW)	Air pressure drop (Pa)	Water flow rate (l/s)	Water pressure drop (kPa)
ECOEV0 3 SLIM 11	1080	5	31	10	46,8	0,47	53,6
		10	33	8	47,1	0,41	41,6
		15	34	7	47,5	0,35	30,9
	950	5	32	9	39,3	0,43	45,2
		10	34	8	39,6	0,37	35,1
		15	35	7	39,9	0,31	26,1
		5	34	8	30,1	0,37	34,6
		10	35	7	30,3	0,32	26,9
		15	36	6	30,5	0,27	20,0
ECOEV0 3 SLIM 21	2150	5	31	19	46,9	0,93	59,2
		10	33	17	47,2	0,81	45,9
		15	34	14	47,6	0,69	34,2
	1890	5	32	18	39,3	0,85	49,9
		10	34	15	39,6	0,74	38,7
		15	35	13	40,0	0,63	28,8
		5	34	15	30,1	0,73	38,0
		10	35	13	30,3	0,64	29,6
		15	36	11	30,5	0,54	22,1
ECOEV0 3 SLIM 26	2550	5	31	23	46,7	1,11	58,5
		10	33	20	47,1	0,96	45,3
		15	34	17	47,5	0,82	33,8
	2250	5	32	21	39,4	1,01	49,6
		10	34	18	39,7	0,88	38,4
		15	35	15	40,1	0,74	28,6
		5	34	18	30,0	0,87	37,7
		10	35	16	30,2	0,75	29,3
		15	36	13	30,5	0,64	21,8

Airflow at velocities: 2.5; 2.2; 1.8 m/s

Water temperature : 45°C / 40°C

RH: 80%

BATTERY MODULES
CHANGE OVER MODULE

Cooling mode Model	Airflow (m³/h)	Air inlet temperature (°C)	Air outlet temperature (°C)	Cooling capacity (kW)	Air pressure drop (Pa)	Water flow rate (l/s)	Water pressure drop (kPa)
ECOEV0 3 SLIM 11	1080	31	19	6	67,8	0,31	29,1
		28	18	5	67,5	0,23	17,6
		25	16	4	60,7	0,18	11,3
	950	31	19	6	58,3	0,28	25,5
		28	17	4	58,1	0,21	15,3
		25	16	3	51,9	0,17	9,8
	780	31	18	5	46,3	0,25	20,4
		28	17	4	46,1	0,19	12,3
		25	15	3	40,8	0,14	8,2
ECOEV0 3 SLIM 21	2150	31	19	13	67,9	0,61	32,1
		28	18	10	67,6	0,46	19,5
		25	16	7	60,8	0,36	12,5
	1890	31	19	12	58,4	0,56	27,9
		28	17	9	58,1	0,42	16,9
		25	16	7	52,0	0,33	10,7
	1550	31	18	10	46,3	0,50	22,5
		28	17	8	46,1	0,37	13,6
		25	15	6	40,8	0,29	8,8
ECOEV0 3 SLIM 26	2550	31	19	15	67,7	0,72	31,9
		28	18	11	67,4	0,54	19,2
		25	16	9	60,7	0,42	12,4
	2250	31	19	14	58,5	0,67	27,7
		28	17	11	58,2	0,50	16,8
		25	16	8	52,1	0,39	10,7
	1840	31	18	12	46,2	0,59	22,3
		28	17	9	46,0	0,44	13,4
		25	15	7	40,8	0,34	8,7

Airflow at velocities: 2,5; 2,2; 1,8 m/s

Water temperature: 7°C / 12°C

RH: 50%

DIRECT EXPANSION MODULE

Heating mode Model	Airflow (m³/h)	Air inlet temperature (°C)	Air outlet temperature (°C)	Heating capacity (kW)	Air pressure drop (Pa)
ECOEV0 3 SLIM 11	970	5	31	9	43,6
		10	33	7	43,9
		15	34	6	44,3
	850	5	32	8	36,4
		10	33	7	36,7
		15	35	6	37,0
	700	5	33	7	28,0
		10	35	6	28,2
		15	36	5	28,4
ECOEV0 3 SLIM 21	1950	5	32	18	43,6
		10	34	16	44,0
		15	36	14	44,3
	1710	5	33	17	36,5
		10	35	15	36,8
		15	36	13	37,1
	1400	5	35	14	27,8
		10	36	13	28,0
		15	38	11	28,3
ECOEV0 3 SLIM 26	2350	5	33	22	43,5
		10	34	20	43,8
		15	36	17	44,2
	2070	5	34	20	36,6
		10	35	18	36,9
		15	37	16	37,2
	1690	5	35	18	27,8
		10	37	16	28,0
		15	38	13	28,2

Airflow at velocities: 2,5; 2,2; 1,8 m/s

Condensation temperature R32: 50°C

RH: 80%



BATTERY MODULES

DIRECT EXPANSION MODULE

Cooling mode Model	Airflow (m³/h)	Air inlet temperature (°C)	Air outlet temperature (°C)	Cooling capacity (kW)	Air pressure drop (Pa)
ECOEV0 3 SLIM 11	970	31	18	7	62,0
		28	16	6	61,7
		25	15	4	61,5
	850	31	18	6	53,3
		28	16	5	53,0
		25	14	4	52,8
	700	31	17	6	42,1
		28	15	5	41,9
		25	14	4	41,7
ECOEV0 3 SLIM 21	1950	31	18	14	62,1
		28	16	11	61,9
		25	15	9	61,6
	1710	31	18	13	53,5
		28	16	10	53,2
		25	14	8	53,0
	1400	31	17	11	42,2
		28	15	9	42,0
		25	14	7	41,9
ECOEV0 3 SLIM 26	2350	31	18	16	62,3
		28	16	13	62,0
		25	15	11	61,7
	2070	31	18	15	53,5
		28	16	12	53,3
		25	14	10	53,1
	1690	31	17	13	42,2
		28	15	11	42,1
		25	14	9	42,0

Airflow at velocities: 2,5; 2,2; 1,8 m/s

Evaporation temperature R32: 5°C

RH: 50%

ELECTRIC HEATING MODULE

Model	Airflow (m³/h)	Air inlet temperature (°C)	Air outlet temperature (°C)	Heating capacity (kW)
ECOEV0 3 SLIM 11	965	5	23	6
		10	28	
		15	33	
	825	5	27	
		10	32	
		15	37	
	690	5	31	
		10	36	
		15	41	
ECOEV0 3 SLIM 21	1865	5	24	12
		10	29	
		15	34	
	1597	5	27	
		10	32	
		15	37	
	1330	5	32	
		10	37	
		15	42	
ECOEV0 3 SLIM 26	2275	5	21	12
		10	26	
		15	31	
	1950	5	23	
		10	28	
		15	33	
	1625	5	27	
		10	32	
		15	37	

Airflow at velocities: 3,5; 3,0; 2,5 m/s

RH: 80%

COMPLEMENTARY MODULES

ACOUSTIC ATTENUATION MODULE

Model	Airflow (m ³ /h)	Air pressure drop (Pa)	Acoustic attenuation - Frequency (Hz)								Total dB(A)
			63	125	250	500	1000	2000	4000	8000	
ECOEV0 3 SLIM 11	500	2	3	6	11	16	23	22	17	14	20
	750	6									
	1000	10									
ECOEV0 3 SLIM 21	1100	9	2	5	10	15	21	20	15	12	20
	1500	14									
	1900	20									
ECOEV0 3 SLIM 26	1500	7	2	5	9	14	19	17	13	10	19
	2000	11									
	2500	16									

PERFORMANCE CURVES

RECOVERY EFFICIENCY CURVE

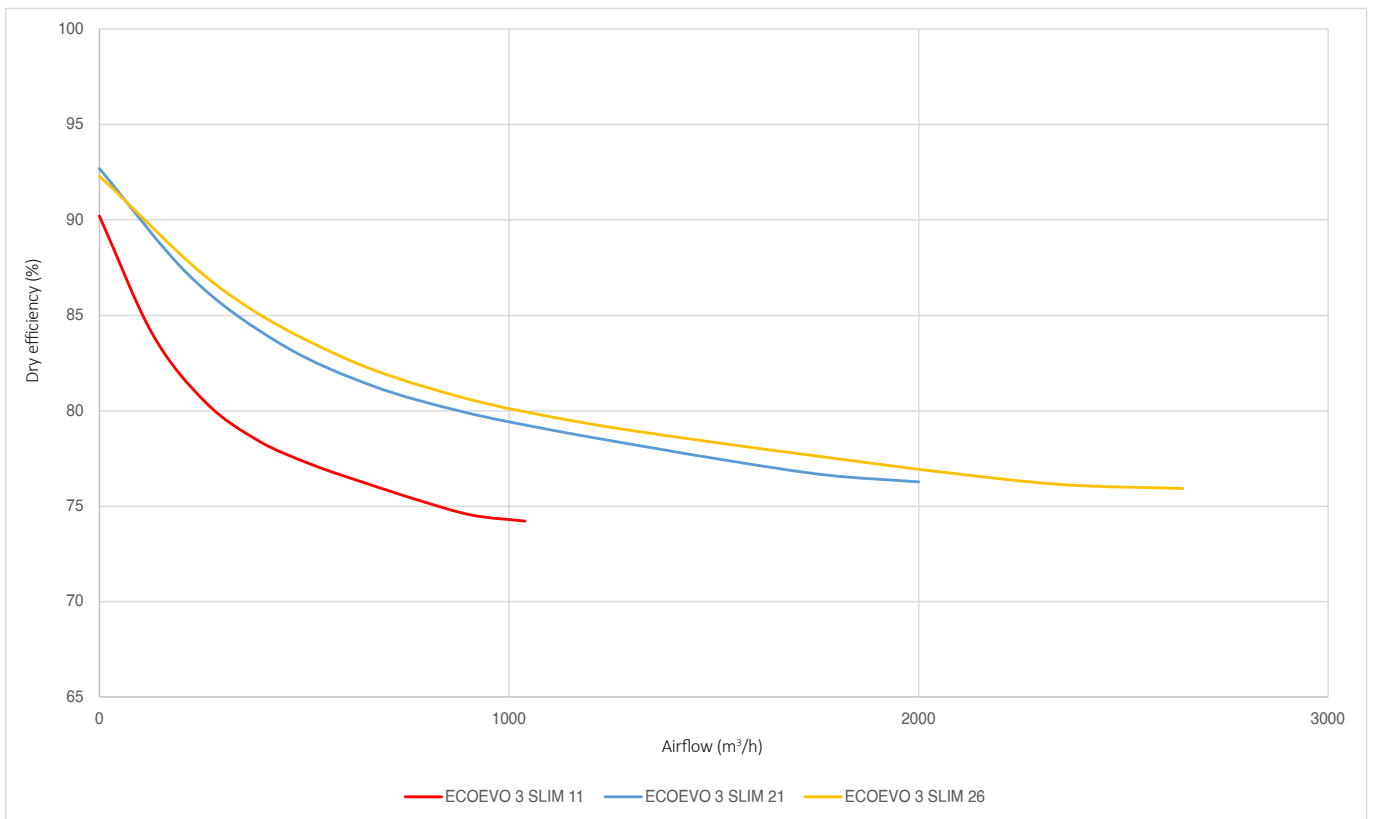



PERFORMANCE CURVES

ECOevo 3 SLIM ePM10 50%/M5

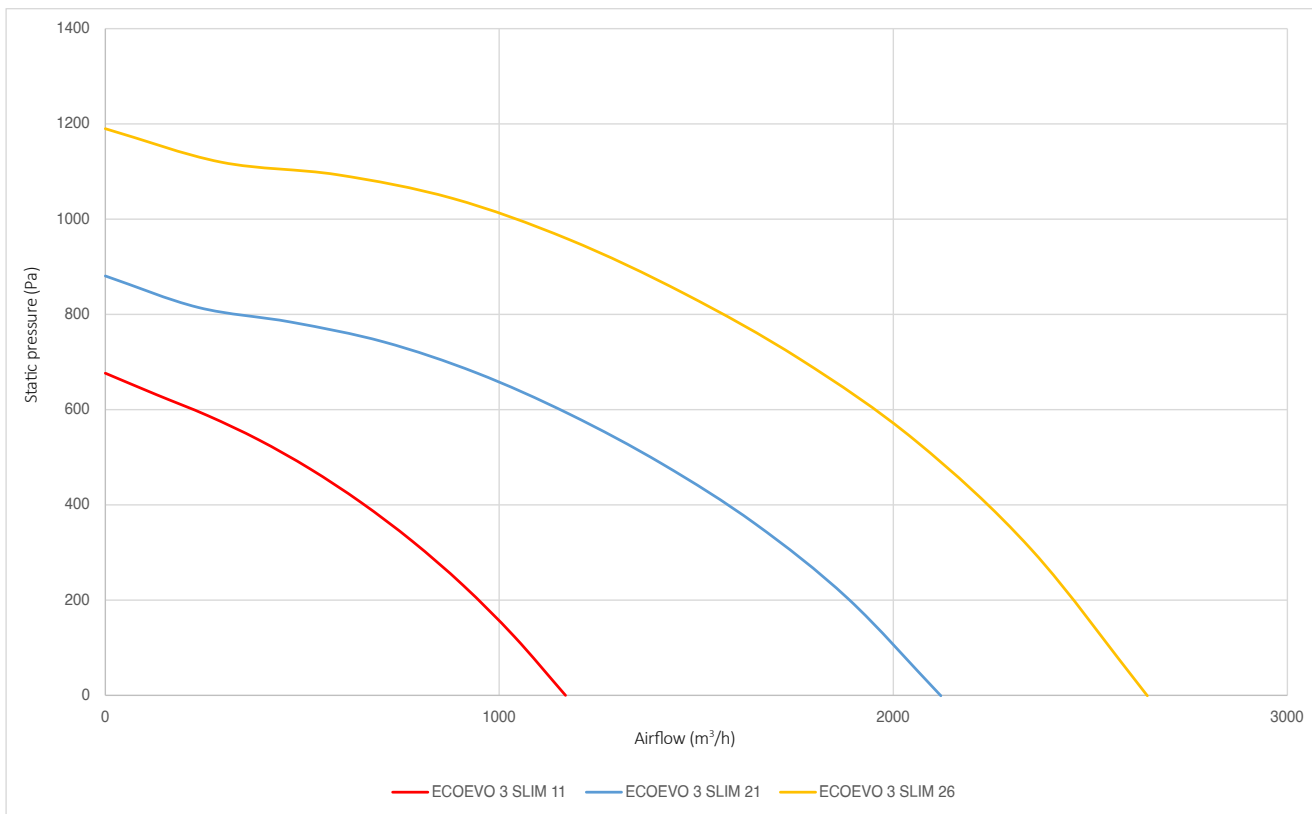

ECOevo 3 SLIM ePM1 50%/F7

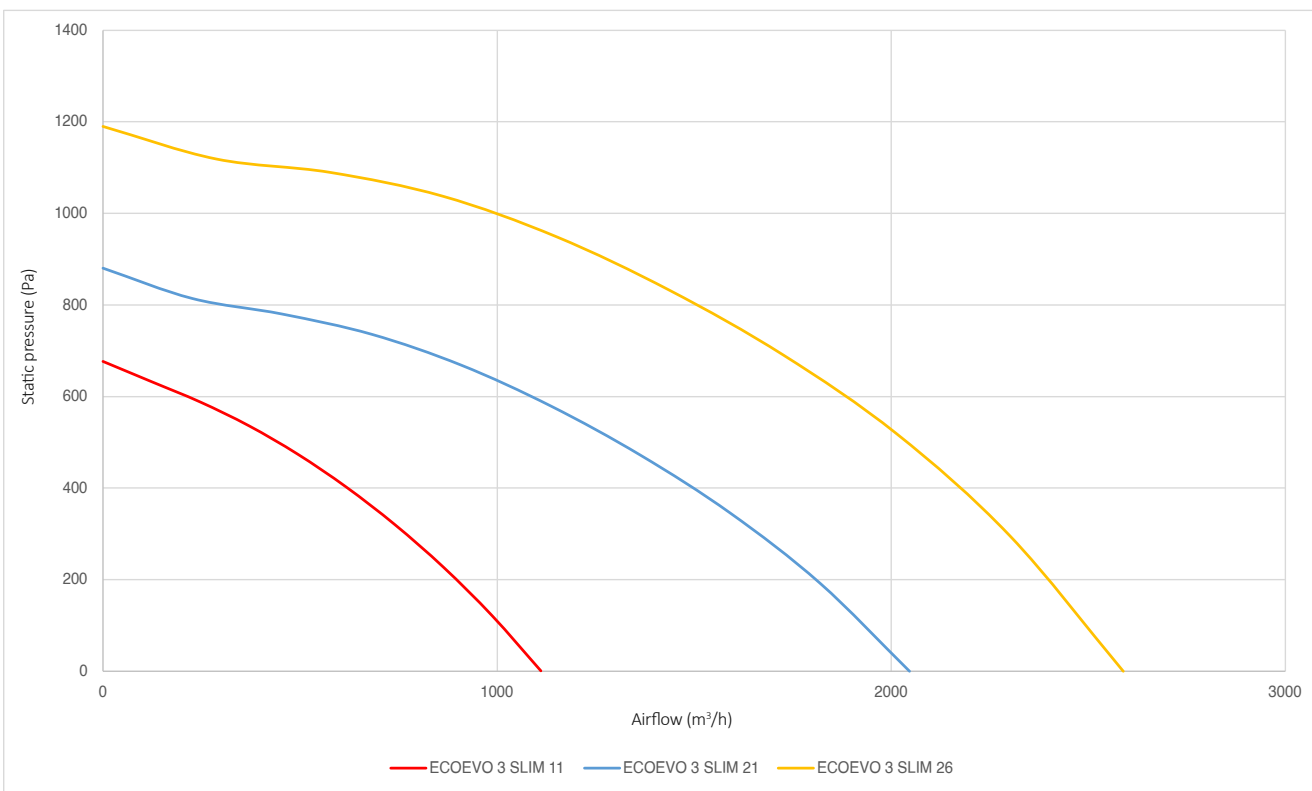

PERFORMANCE CURVES

ECOEVO 3 SLIM ePM1 80%/F9

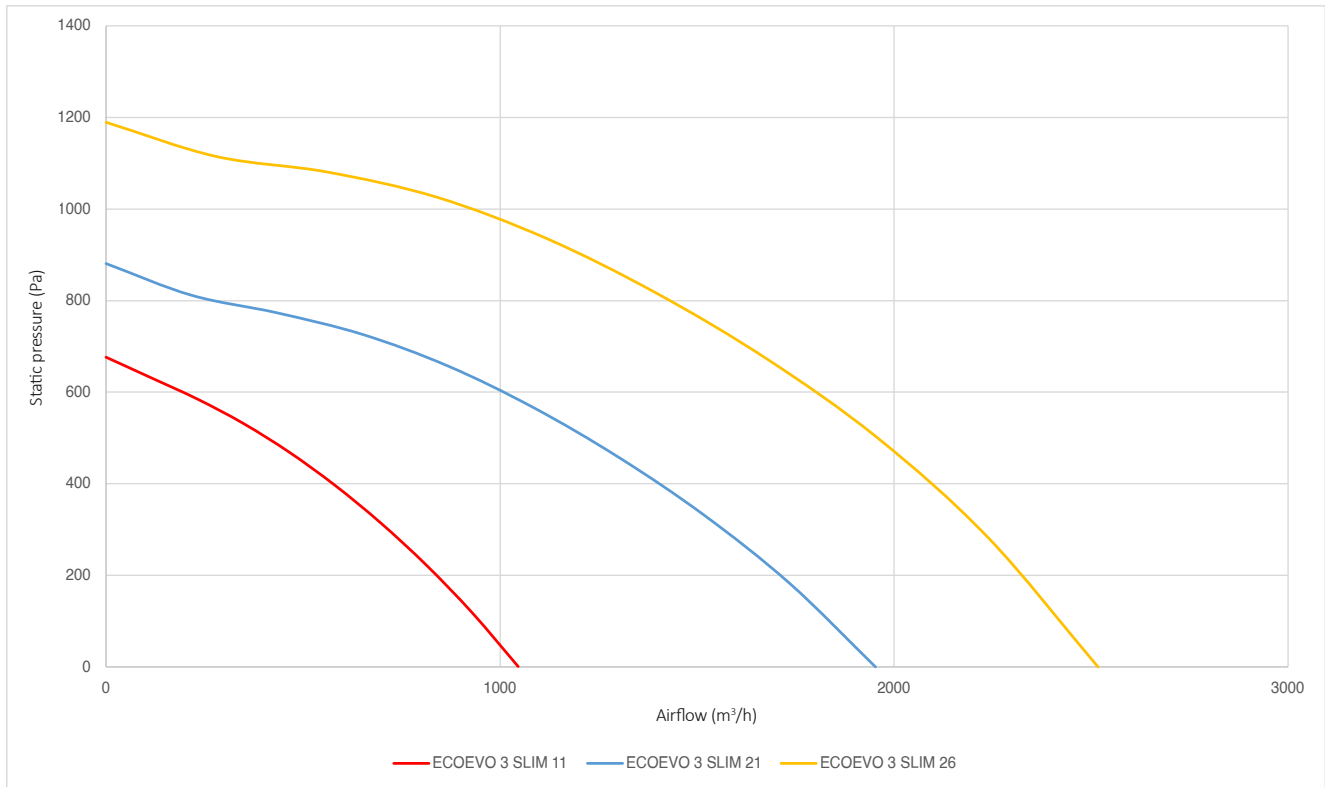

ECOEVO 3 SLIM ePM10 50%/M5 + ePM1 50%/F7

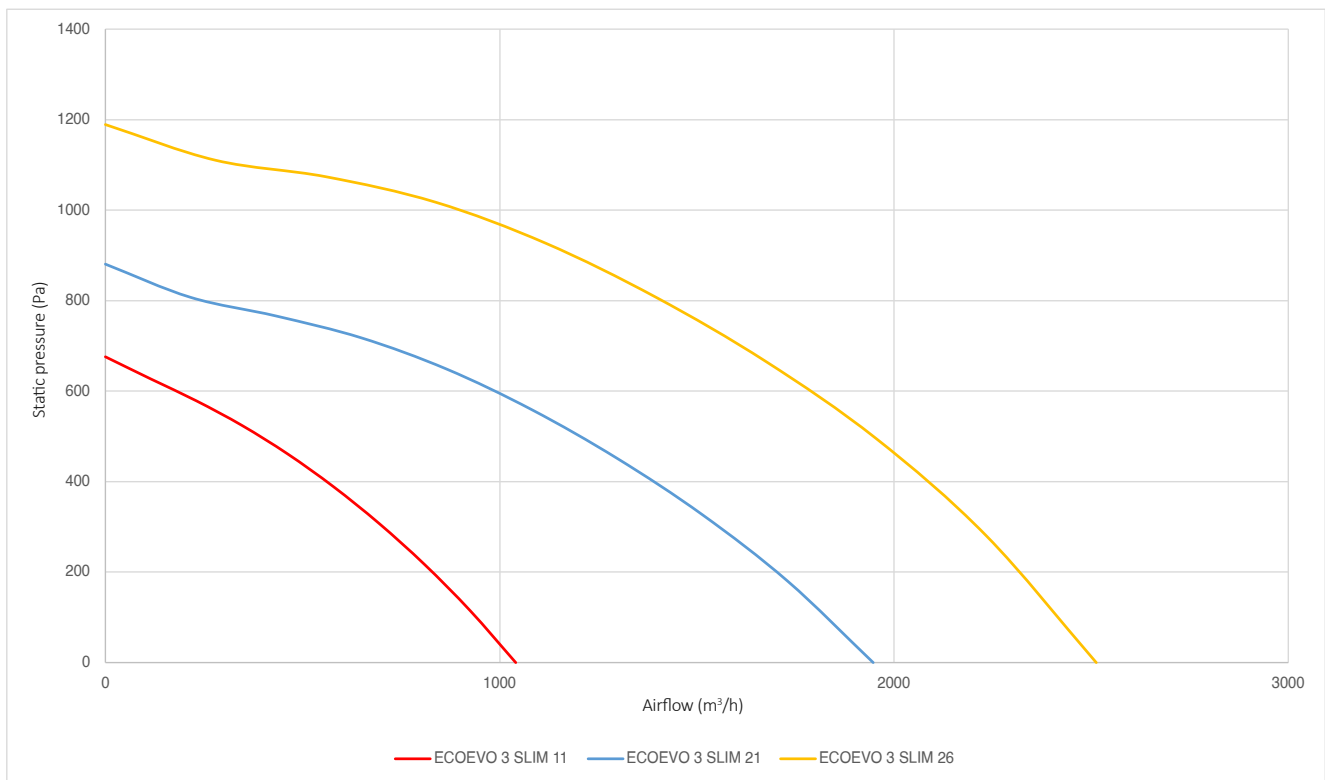



PERFORMANCE CURVES

ECOevo 3 SLIM ePM10 50%/M5 + ePM1 80%/F9

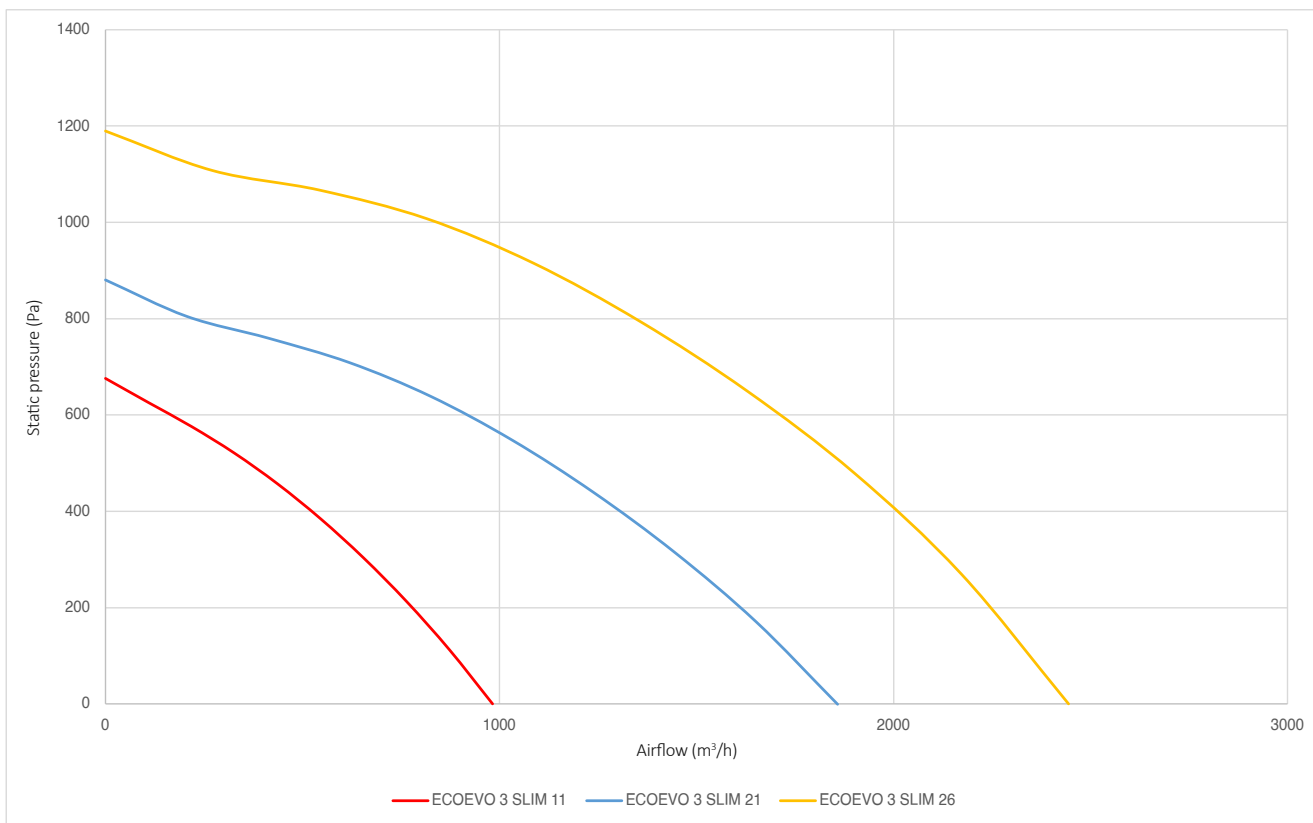

ECOevo 3 SLIM ePM1 50%/F7 + ePM1 80%/F9

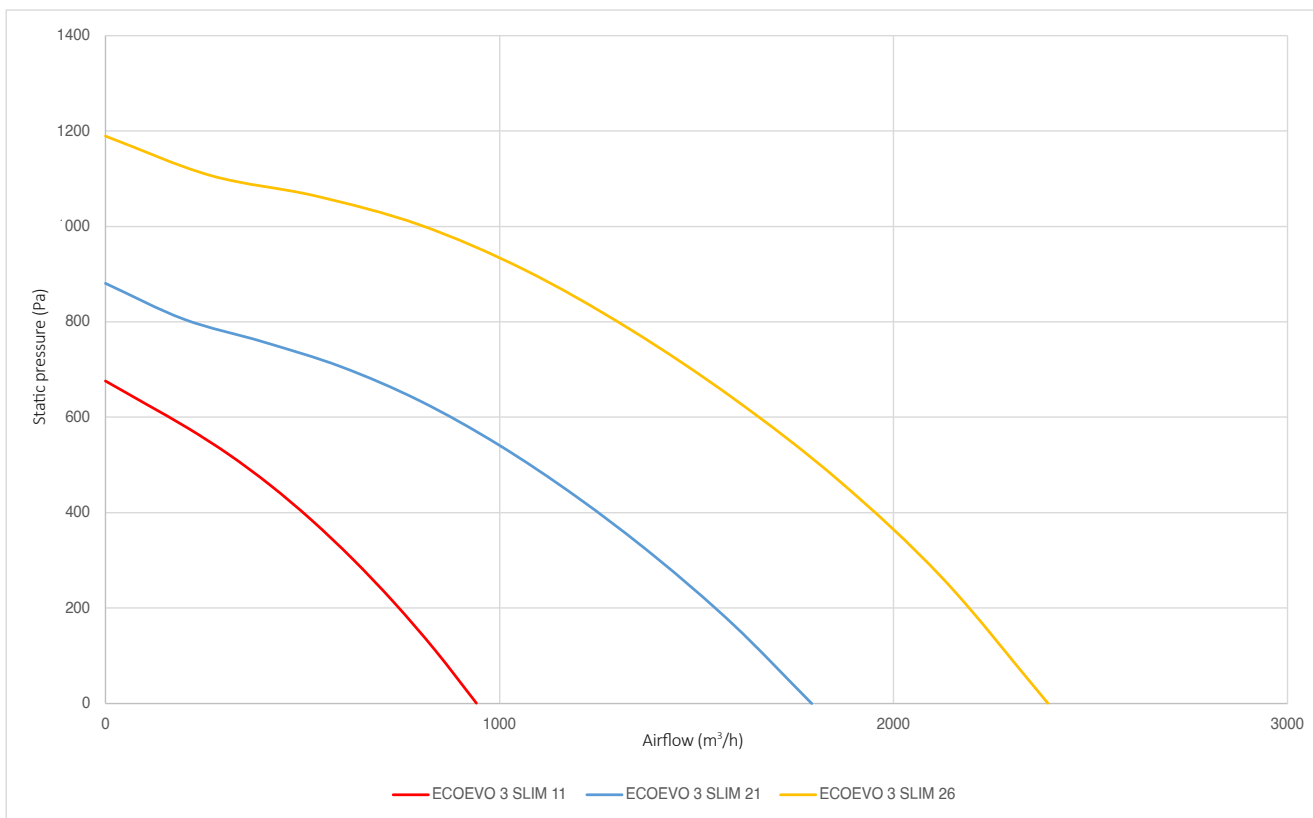

PERFORMANCE CURVES

ECOEVO 3 SLIM WATER HEATING MODULE

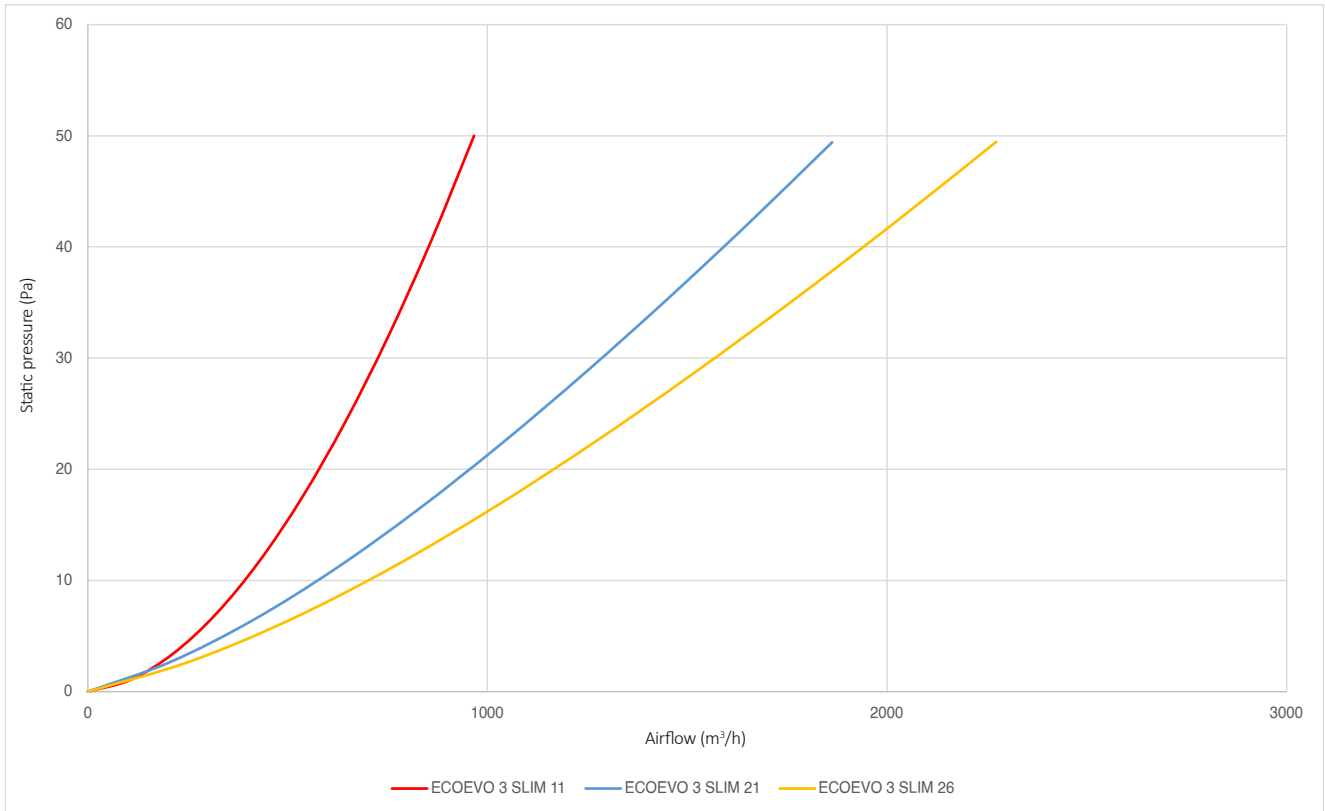

ECOEVO 3 SLIM CHANGE OVER MODULE

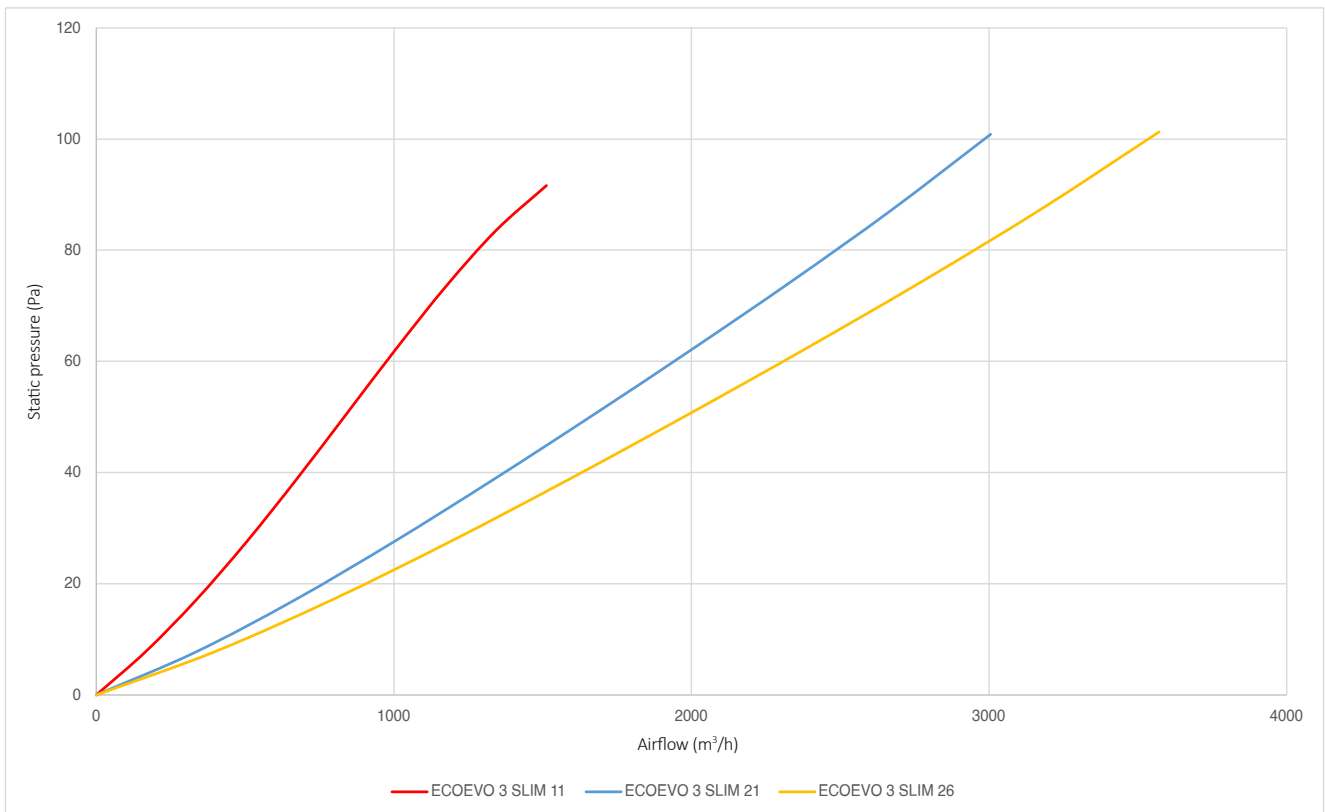



PERFORMANCE CURVES

ECOEOVO 3 SLIM DX MODULE

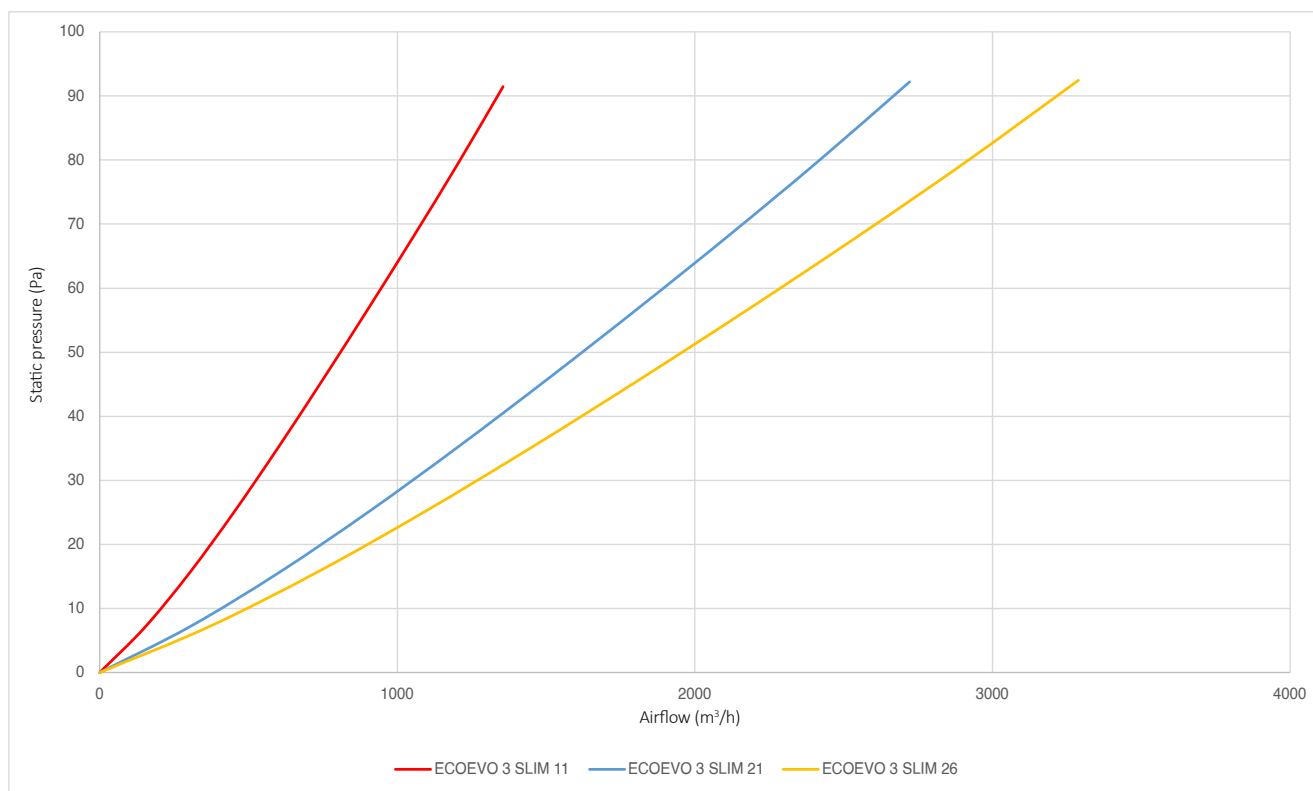

DX Battery – Direct Expansion Module

DIMENSIONS

ECOEOVO 3 SLIM H	11	21	26
A (mm)	350	450	450
L (mm)	1000	1100	1300
P (mm)	1485	1800	1900
D (mm)	250	355	355
C (mm)	455	505	605
H (mm)	290	390	390
E (mm)	175	225	225
Weight (kg)	137	213	244

ECOEOVO 3 SLIM V	11	21	26
A (mm)	1100	1210	1360
L (mm)	350	450	450
P (mm)	1485	1800	1900
D (mm)	250	355	355
C (mm)	290	390	390
H (mm)	505	560	635
E (mm)	283	310	348
F (mm)	818	900	1013
Weight (kg)	137	213	244

DIMENSIONS

ECOEVO 3 SLIM H

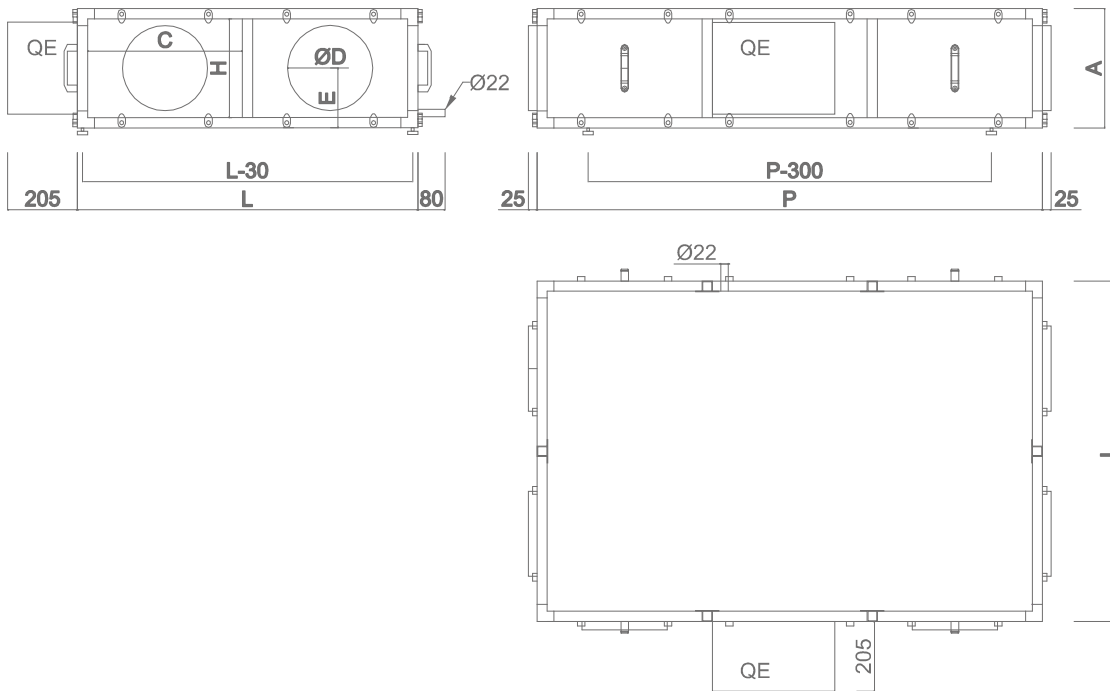

ECOEVO 3 SLIM V

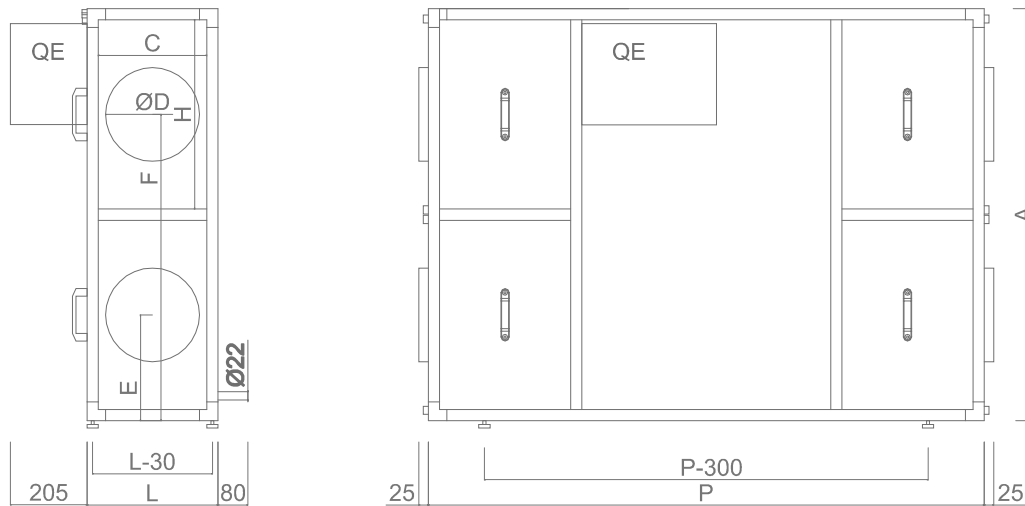

NOTE: MAINTENANCE CLEARANCE AND UNIT ACCESS DISTANCE | 750 MM



DIMENSIONS

WATER HEATING MODULE

ECOEV0 3 SLIM / BAA	11	21	26
A (mm)	350	450	450
L (mm)	550	625	725
P (mm)	350	350	350
Ø Hydraulic Connection (pol.)	1/2"	3/4"	3/4"
Weight (kg)	22	28	31

CHANGE OVER MODULE

ECOEV0 3 SLIM / BCA	11	21	26
A (mm)	350	450	450
L (mm)	650	700	800
P (mm)	450	620	620
Ø Hydraulic Connection (pol.)	3/4"	3/4"	3/4"
Ø Condensate Outlet (mm)		22	
Weight (kg)	43	63	70

DIRECT EXPANSION MODULE

ECOEV0 3 SLIM / BCR	11	21	26
A (mm)	350	450	450
L (mm)	650	700	800
P (mm)	450	620	620
Ø Liquid (mm)	22	22	22
Ø Steam (mm)	12	12	16
Ø Condensate Outlet (mm)		22	
Weight (kg)	41	62	68

ELECTRIC HEATING MODULE

ECOEV0 3 SLIM / BRE	11	21	26
A (mm)	350	450	450
L (mm)	550	625	725
P (mm)	350	350	350
Weight (kg)	17	23	25

ACOUSTIC ATTENUATION MODULE

ECOEV0 3 SLIM / MAA	11	21	26
A (mm)	350	450	450
L (mm)	500	550	650
P (mm)	700	700	700
Weight (kg)	29	34	36

STANDARD CONFIGURATIONS HORIZONTAL MODEL

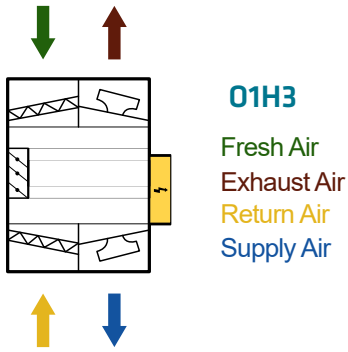

CONFIGURATIONS HORIZONTAL MODEL

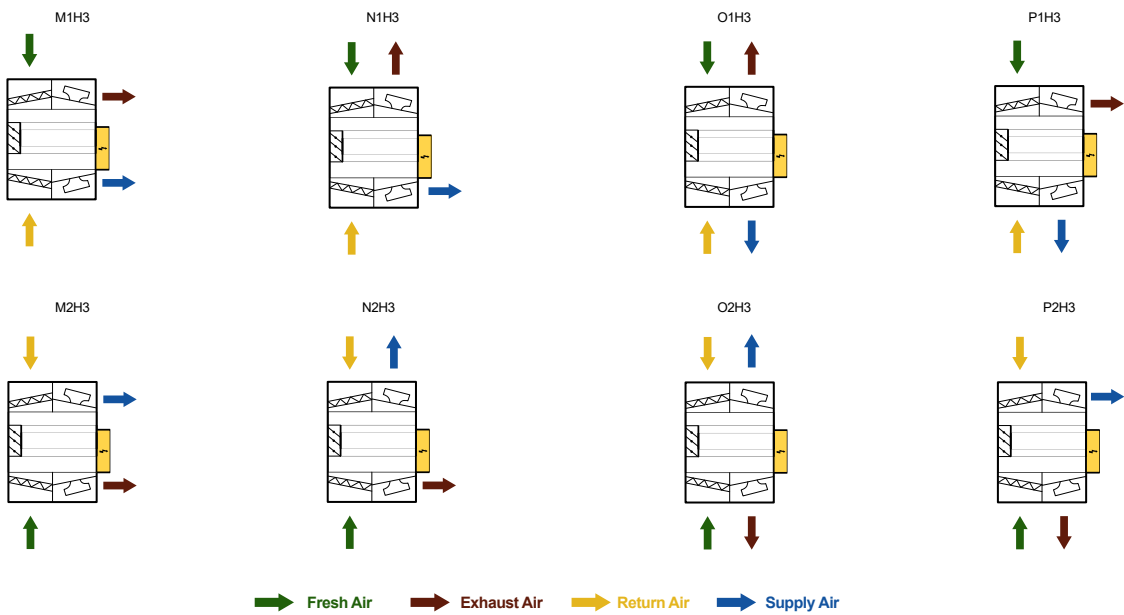

CONFIGURATIONS VERTICAL MODEL

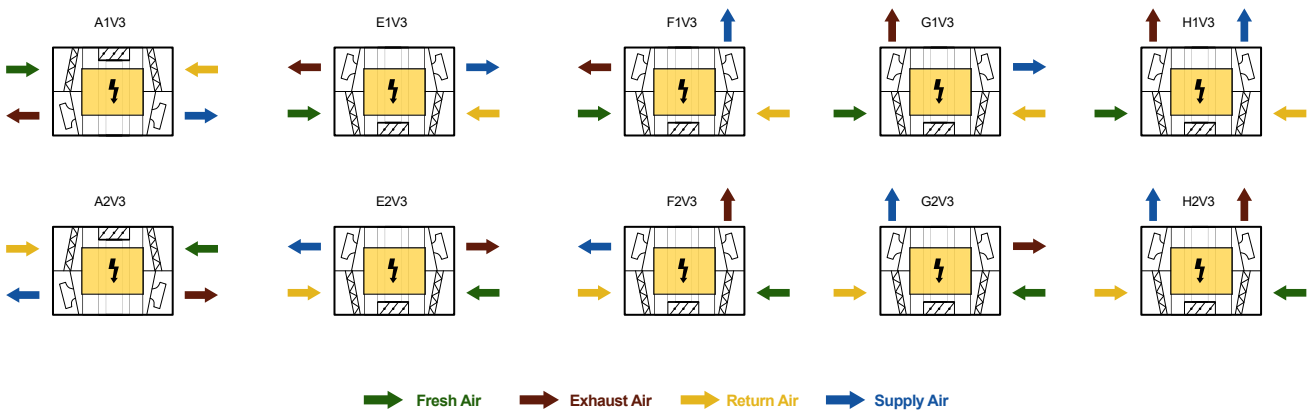

NOTE: FOR VERTICAL MODELS, INSTALLATION OF RAIN ROOF IS NOT POSSIBLE IN CONFIGURATIONS F, G, H



ERP VERIFICATION DOCUMENT

MANUFACTURER		ARFIT AIR CONDITIONING, S.A.		
Model		11	21	26
Type		UVNR UVB		
Transmission Type		Variable Speed	Variable Speed	Variable Speed
Heat Recovery System Type		OTHER		
Heat Recovery Thermal Efficiency	%	74.2	76.5	75.8
Nominal Airflow	m ³ /s	0.281	0.538	0.693
Input Power	kW	0.226	0.48	0.717
SPFint	W m ³ /s	1104.0	1333.2	1573.5
Frontal Velocity	m/s	5.73	5.44	7.00
Nominal External Pressure	Pa	100	100	105
Decrease in internal pressure ventilation	Pa	296	433	462
Static Efficiency of Fans	%	49.2	59.6	54.9
Maximum Declared Internal/External Leakage Rate	%	3.3/4.2	3,4/4,1	3,8/3,9
Filter Classification		F7/M5		
Description: Visual notice regarding filters		The filters warning is displayed on the unit's control system, either via a warning light or on-screen message, depending on the control system used. It is of the utmost importance to replace the filters regularly to improve the unit's performance and energy efficiency.		
Sound Power Level (Lwa)	dB(A)	69	64	70
Website		www.arfit.pt		

ECOevo 3

INDEX



Plug & Play



EC
Technology



Controlled unit



2 Levels of
filtration



25 mm
panel

DESCRIPTION

Heat recovery unit ECOevo 3, sound-insulated, for indoor or outdoor installation, with removable side panels that facilitate access for maintenance. Incorporates integrated electrical panel with isolating switch for greater safety and ease of operation.

Robust construction with 25 mm double-wall panels, ensuring good thermal and acoustic insulation. The outer face in Magnelis steel with corrosion class C5 ensures high durability even in demanding environments.

Available in 5 sizes, with airflow rates between 2600 and 8700 m³/h, adapting to different ventilation applications. Equipped with EC Plug Fan and heat exchanger with efficiency up to 90%, enabling high energy efficiency and reduced consumption in HVAC systems.

STANDARDS AND CERTIFICATIONS



ADVANTAGES

- Modular monoblock Plug & Play unit designed for higher airflow rates.
- Double panels with 25 mm insulation.
- Corrosion class C5.
- Low-consumption electronically commutated motor.
- Possible integration of Be.On module with cloud connection and Be.Smart monitoring.
- 3-way valve and actuator included.
- Integrated electrical panel.

ACCESSORIES

- ePM10 50%/M5 filter
- ePM1 50%/F7 filter
- ePM1 80%/F9 filter
- Protection for rain
- Rain Roof
- Heating / cooling coil modules
- Acoustic attenuation module
- Constant airflow control
- CO₂ control

COMPONENTS

FILTERS

The filtration system includes two filters with filtration classes ePM10 50% (M5), ePM1 50% (F7) or ePM1 80% (F9), in accordance with EN 779 / ISO 16890. The parallel mounting system uses dedicated rails that ensure airtightness, maintaining bypass leakage within class F9 (EN 1886).

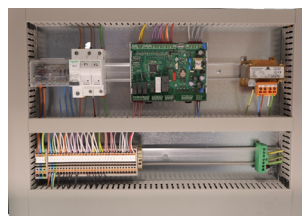

FAN

EC brushless Plug Fan with backward-curved blades, compact design and high available pressures. The aerodynamic rotor geometry, balanced according to ISO 1940 G2.5 and with vibration levels in accordance with AMCA 204, combined with EC motor with insulation class F and IP55 protection, ensures high capacity, efficiency and performance (IE5), even at high resistance levels.

**HEAT EXCHANGER**

Parallel-flow heat exchangers. Enable up to 90% recovery of sensible heat from exhaust air to supply air, with efficiency certified by Eurovent. The aluminium plate design with double-fold joints ensures structural integrity and airtightness under pressures up to 1500 Pa.

**WATER HEATING MODULE**

Water heating coil composed of copper tubes with aluminium fins, mechanically expanded to ensure maximum thermal contact. With steel or copper headers and galvanized steel structure, all units undergo strict quality control, with tightness and integrity verified at 32 bar in factory.

**CHANGE OVER MODULE**

Water coil allowing both heating and cooling with the same coil. Composed of copper tubes, aluminium fins mechanically expanded, copper headers and galvanized steel structure. Tightness and integrity are rigorously tested at 32 bar. Module equipped with stainless steel condensate tray. Includes 3-way valve and actuator.

DIRECT EXPANSION COOLING MODULE

Direct expansion coil for R32 refrigerant. Composed of copper tubes, aluminium fins mechanically expanded, copper headers and galvanized steel structure. Factory tested at 60 bar. Equipped with stainless steel condensate tray.

ELECTRIC HEATING MODULE

Electric finned heating elements in 8 mm diameter steel tube with 25 x 50 mm fins of the same material, with quick-fix screw and M4 threaded terminals. Designed for air heating applications. Mounted in frame and placed on rails for easy removal.

ACOUSTIC ATTENUATION MODULE

Baffles made of mineral wool, with the air-contact surface in non-fragmenting material, protected by mesh or micro-perforated sheet, with galvanized steel

**CHARACTERISTICS**

ECOevo 3	40	44	56	66	87
Motor Power (kW)	2 x 1,35	2 x 1,35	2 x 2,5	2 x 2,5	2 x 2,5
Rotational Speed (rpm)	2920	2920	3640	2970	2650
Power Supply (V F Hz)	230 1 50			400 3 50	
IMAX (A)	11,9	11,9	7,9	7,9	8,5
Sound Pressure (dB(A)) **	53	54	60	57	65

** Sound pressure level at 4 m, measured in open field according to ISO 3744

BATTERY MODULES
WATER HEATING MODULE

Model	Airflow (m³/h)	Air inlet temperature (°C)	Air outlet temperature (°C)	Heating capacity (kW)	Air pressure drop (Pa)	Water flow rate (l/s)	Water pressure drop (kPa)
ECOEV0 3 40	3322	5	34	32	49,1	0,40	9,8
		10	36	30	49,5	0,36	8,8
		15	39	27	50,0	0,33	7,9
	2847	5	35	29	39,8	0,36	8,6
		10	38	27	40,2	0,33	7,8
		15	40	25	40,5	0,30	7,0
	2373	5	37	26	31,1	0,32	7,4
		10	40	24	31,4	0,29	6,8
		15	42	22	31,7	0,27	6,1
ECOEV0 3 44	4193	5	34	41	49,1	0,50	12,6
		10	36	38	49,5	0,46	10,9
		15	39	35	50,0	0,42	9,4
	3594	5	35	37	39,8	0,46	10,5
		10	38	34	40,2	0,42	9,3
		15	40	31	40,6	0,38	8,3
	2995	5	37	33	31,1	0,40	8,8
		10	40	30	31,4	0,37	8,0
		15	42	28	31,7	0,34	7,2
ECOEV0 3 56	4193	5	34	41	49,1	0,50	12,6
		10	36	38	49,5	0,46	10,9
		15	39	35	50,0	0,42	9,4
	3594	5	35	37	39,8	0,46	10,5
		10	38	34	40,2	0,42	9,3
		15	40	31	40,6	0,38	8,3
	2995	5	37	33	31,1	0,40	8,8
		10	40	30	31,4	0,37	8,0
		15	42	28	31,7	0,34	7,2
ECOEV0 3 66	5717	5	34	56	49,1	0,68	11,4
		10	36	51	49,5	0,63	9,8
		15	39	47	50,0	0,58	8,7
	4900	5	35	50	39,8	0,62	9,6
		10	38	46	40,2	0,57	8,6
		15	40	43	40,5	0,52	7,7
	4084	5	37	45	31,1	0,55	8,2
		10	40	41	31,4	0,51	7,4
		15	42	38	31,7	0,46	6,7
ECOEV0 3 87	9198	5	34	91	49,1	1,11	21,1
		10	37	84	49,5	1,03	18,2
		15	39	77	50,0	0,94	15,5
	7884	5	36	82	39,8	1,01	17,6
		10	38	76	40,2	0,93	15,2
		15	41	69	40,6	0,85	13,0
	6570	5	38	73	31,1	0,89	14,2
		10	40	67	31,4	0,83	12,3
		15	42	62	31,7	0,76	10,5

Airflow velocities: 3,5; 3,0; 2,5 m/s

Water temperature : 80°C / 60°C

RH: 80%



BATTERY MODULES

CHANGE OVER MODULE

Heating mode Model	Airflow (m³/h)	Air inlet temperature (°C)	Air outlet temperature (°C)	Heating capacity (kW)	Air pressure drop (Pa)	Water flow rate (l/s)	Water pressure drop (kPa)
ECOEV0 3 40	4110	5	31	37	46,7	1,78	61,3
		10	33	32	47,1	1,55	47,5
		15	34	27	47,5	1,32	35,4
	3620	5	32	34	39,4	1,62	51,7
		10	34	29	39,6	1,41	40,2
		15	35	25	40,0	1,20	29,9
	2960	5	34	29	30,0	1,40	39,5
		10	35	25	30,2	1,21	30,6
		15	36	21	30,4	1,03	22,8
ECOEV0 3 44	4960	5	32	46	39,9	2,22	51,6
		10	33	39	40,2	1,90	39,2
		15	35	33	40,5	1,61	29,0
	4500	5	33	43	34,9	2,06	45,3
		10	34	37	35,2	1,77	34,4
		15	35	31	35,5	1,50	25,5
	4000	5	33	39	29,8	1,87	37,9
		10	35	34	30,0	1,62	29,3
		15	36	28	30,3	1,37	21,8
ECOEV0 3 56	5580	5	31	50	46,8	2,42	60,4
		10	33	44	47,1	2,10	46,9
		15	34	36	47,5	1,76	33,9
	4910	5	32	46	39,3	2,20	50,9
		10	33	39	39,6	1,89	38,6
		15	35	33	40,0	1,60	28,7
	4020	5	33	39	30,0	1,87	38,1
		10	35	34	30,2	1,63	29,6
		15	36	29	30,5	1,38	21,9
ECOEV0 3 66	6630	5	31	58	46,7	2,82	38,4
		10	32	51	47,1	2,44	29,5
		15	34	43	47,5	2,07	21,7
	5840	5	32	53	39,3	2,57	32,4
		10	33	46	39,6	2,23	24,9
		15	35	39	40,0	1,88	18,4
	4480	5	34	44	27,5	2,11	22,5
		10	35	38	27,7	1,83	17,4
		15	36	32	27,9	1,55	12,8
ECOEV0 3 87	8890	5	31	80	46,8	3,84	51,3
		10	33	69	47,1	3,34	39,8
		15	34	58	47,5	2,79	28,7
	7820	5	32	73	39,3	3,50	43,2
		10	33	62	39,6	3,00	32,7
		15	35	53	39,9	2,54	24,2
	6400	5	33	62	29,9	2,98	32,3
		10	35	54	30,2	2,59	25,0
		15	36	45	30,4	2,19	18,5

Airflow at velocities: 2,5; 2,2; 1,8 m/s

Water temperature : 45°C / 40°C

RH: 80%

BATTERY MODULES
CHANGE OVER MODULE

Cooling mode Model	Airflow (m³/h)	Air inlet temperature (°C)	Air outlet temperature (°C)	Cooling capacity (kW)	Air pressure drop (Pa)	Water flow rate (l/s)	Water pressure drop (kPa)
ECOEV0 3 40	4110	31	19	24	67,7	1,16	33,4
		28	18	18	67,5	0,88	20,2
		25	16	14	60,7	0,69	13,1
	3620	31	19	23	58,4	1,08	29,1
		28	17	17	58,2	0,81	17,6
		25	16	13	52,0	0,63	11,3
	2960	31	18	20	46,1	0,95	23,4
		28	17	15	45,9	0,72	14,1
		25	15	12	40,7	0,55	9,0
ECOEV0 3 44	4960	31	19	31	59,0	1,47	29,1
		28	17	23	58,8	1,11	17,5
		25	16	18	52,6	0,86	11,3
	4500	31	19	29	52,7	1,38	26,0
		28	17	22	52,5	1,04	15,8
		25	15	17	46,7	0,80	10,0
	4000	31	18	27	45,9	1,28	22,8
		28	17	20	45,7	0,97	13,9
		25	15	16	40,5	0,74	9,0
ECOEV0 3 56	5580	31	19	33	67,8	1,58	33,1
		28	18	25	67,5	1,19	19,9
		25	16	20	60,8	0,93	12,9
	4910	31	19	31	58,4	1,46	28,8
		28	17	23	58,1	1,10	17,3
		25	16	18	52,0	0,85	11,1
	4020	31	18	27	46,2	1,28	22,9
		28	17	20	46,0	0,97	13,9
		25	15	16	40,7	0,74	9,0
ECOEV0 3 66	6630	31	19	38	67,7	1,83	20,2
		28	18	29	67,5	1,37	12,1
		25	16	22	60,7	1,06	8,2
	5840	31	19	36	58,4	1,69	17,6
		28	17	27	58,1	1,27	10,4
		25	16	20	52,0	0,97	7,4
	4480	31	18	30	42,8	1,44	13,1
		28	17	22	42,6	1,07	8,3
		25	16	16	37,6	0,74	5,5
ECOEV0 3 87	8890	31	19	52	67,8	2,50	27,6
		28	18	39	67,5	1,88	16,6
		25	16	31	60,7	1,47	10,7
	7820	31	19	48	58,3	2,31	24,0
		28	17	36	58,1	1,73	14,4
		25	16	28	51,9	1,35	9,3
	6400	31	18	43	46,1	2,04	19,2
		28	17	32	45,9	1,53	11,5
		25	15	25	40,7	1,17	7,8

Airflow at velocities:: 2,5; 2,2; 1,8 m/s

Water temperature : 7°C / 12°C

RH: 50%



BATTERY MODULES

DIRECT EXPANSION MODULE

Heating mode Model	Airflow (m³/h)	Air inlet temperature (°C)	Air outlet temperature (°C)	Heating capacity (kW)	Air pressure drop (Pa)
ECOEV0 3 40	3750	5	32	34	43,4
		10	33	30	43,7
		15	35	26	44,1
	3300	5	33	31	36,5
		10	34	27	36,8
		15	36	24	37,1
	2700	5	34	27	27,8
		10	36	24	28,0
		15	37	21	28,2
ECOEV0 3 44	4920	5	31	44	43,4
		10	33	39	43,7
		15	35	34	44,1
	4330	5	32	40	36,5
		10	34	36	36,8
		15	36	31	37,1
	3540	5	34	35	27,8
		10	35	31	28,0
		15	37	27	28,2
ECOEV0 3 56	4920	5	31	44	43,4
		10	33	39	43,7
		15	35	34	44,1
	4330	5	32	40	36,5
		10	34	36	36,8
		15	36	31	37,1
	3540	5	34	35	27,8
		10	35	31	28,0
		15	37	27	28,2
ECOEV0 3 66	6130	5	32	57	43,5
		10	34	51	43,8
		15	36	44	44,2
	5390	5	33	52	36,5
		10	35	46	36,8
		15	37	40	37,1
	4410	5	35	45	27,8
		10	36	40	28,0
		15	38	35	28,3
ECOEV0 3 87	8260	5	33	78	43,5
		10	34	69	43,8
		15	36	60	44,1
	7270	5	34	71	36,5
		10	35	63	36,8
		15	37	55	37,1
	5950	5	35	62	27,9
		10	37	55	28,1
		15	38	47	28,3

Airflow at velocities:: 2,5; 2,2; 1,8 m/s

Condensing temperature R32: 50°C

RH: 80%

BATTERY MODULES
DIRECT EXPANSION MODULE

Cooling mode Model	Airflow (m³/h)	Air inlet temperature (°C)	Air outlet temperature (°C)	Cooling power (kW)	Air pressure drop (Pa)
ECOEV0 3 40	3750	31	18	26	62,1
		28	16	21	61,8
		25	15	17	61,5
	3300	31	18	24	53,4
		28	16	20	53,2
		25	14	15	52,9
	2700	31	17	21	42,2
		28	15	17	42,0
		25	14	14	41,8
ECOEV0 3 44	4920	31	18	35	62,2
		28	16	28	61,9
		25	15	22	61,6
	4330	31	18	32	53,5
		28	16	26	53,3
		25	14	21	53,0
	3540	31	17	28	42,2
		28	15	23	42,1
		25	14	18	41,9
ECOEV0 3 56	4920	31	18	35	62,2
		28	16	28	61,9
		25	15	22	61,6
	4330	31	18	32	53,5
		28	16	26	53,3
		25	14	21	53,0
	3540	31	17	28	42,2
		28	15	23	42,1
		25	14	18	41,9
ECOEV0 3 66	6130	31	18	43	62,4
		28	16	35	62,1
		25	15	27	61,8
	5390	31	18	39	53,6
		28	16	32	53,4
		25	14	25	53,2
	4410	31	17	35	42,3
		28	15	29	42,2
		25	14	23	42,0
ECOEV0 3 87	8260	31	18	57	62,4
		28	16	47	62,1
		25	15	37	61,8
	7270	31	18	53	53,6
		28	16	43	53,4
		25	14	34	53,2
	5950	31	17	47	42,4
		28	15	39	42,2
		25	14	31	42,0

Airflow at velocities:: 2,5; 2,2; 1,8 m/s

Evaporation temperature R32: 5°C

RH: 50%



BATTERY MODULES

ELECTRIC HEATING MODULE

Heating mode Model	Airflow (m³/h)	Air inlet temperature (°C)	Air outlet temperature (°C)	Heating capacity (kW)
ECOEV0 3 40	3320	5	21	18
		10	10	
		15	15	
	2845	5	5	
		10	10	
		15	15	
	2375	5	5	
		10	10	
		15	15	
ECOEV0 3 44	4195	5	24	27
		10	10	
		15	15	
	3595	5	5	
		10	10	
		15	15	
	2995	5	5	
		10	10	
		15	15	
ECOEV0 3 56	4195	5	24	27
		10	10	
		15	15	
	3595	5	5	
		10	10	
		15	15	
	2995	5	5	
		10	10	
		15	15	
ECOEV0 3 66	5715	5	24	36
		10	10	
		15	15	
	4900	5	5	
		10	10	
		15	15	
	4085	5	5	
		10	10	
		15	15	
ECOEV0 3 87	9200	5	20	48
		10	10	
		15	15	
	7885	5	5	
		10	10	
		15	15	
	6570	5	5	
		10	10	
		15	15	

Airflow at velocities: 3,5; 3,0; 2,5 m/s

RH: 80%

ACOUSTIC ATTENUATION MODULE

Model	Airflow (m³/h)	Air pressure drop (Pa)	Acoustic attenuation - Frequency (Hz)								
			63	125	250	500	1000	2000	4000	8000	Total dB(A)
ECOEV0 3 40	2800	21									
	3300	28	2	5	9	14	19	17	13	10	19
	3800	43									
ECOEV0 3 44	3000	17									
	3600	23	3	6	11	16	23	22	17	14	20
	4200	32									
ECOEV0 3 56	3900	24									
	4600	41	3	6	11	16	23	22	17	14	20
	5300	53									
ECOEV0 3 66	5000	40									
	5700	63	3	6	11	16	23	22	17	14	20
	6400	78									
ECOEV0 3 87	6900	68									
	7600	80	2	5	9	14	19	17	13	10	19
	8300	93									

PERFORMANCE CURVES

RECOVERY EFFICIENCY CURVE

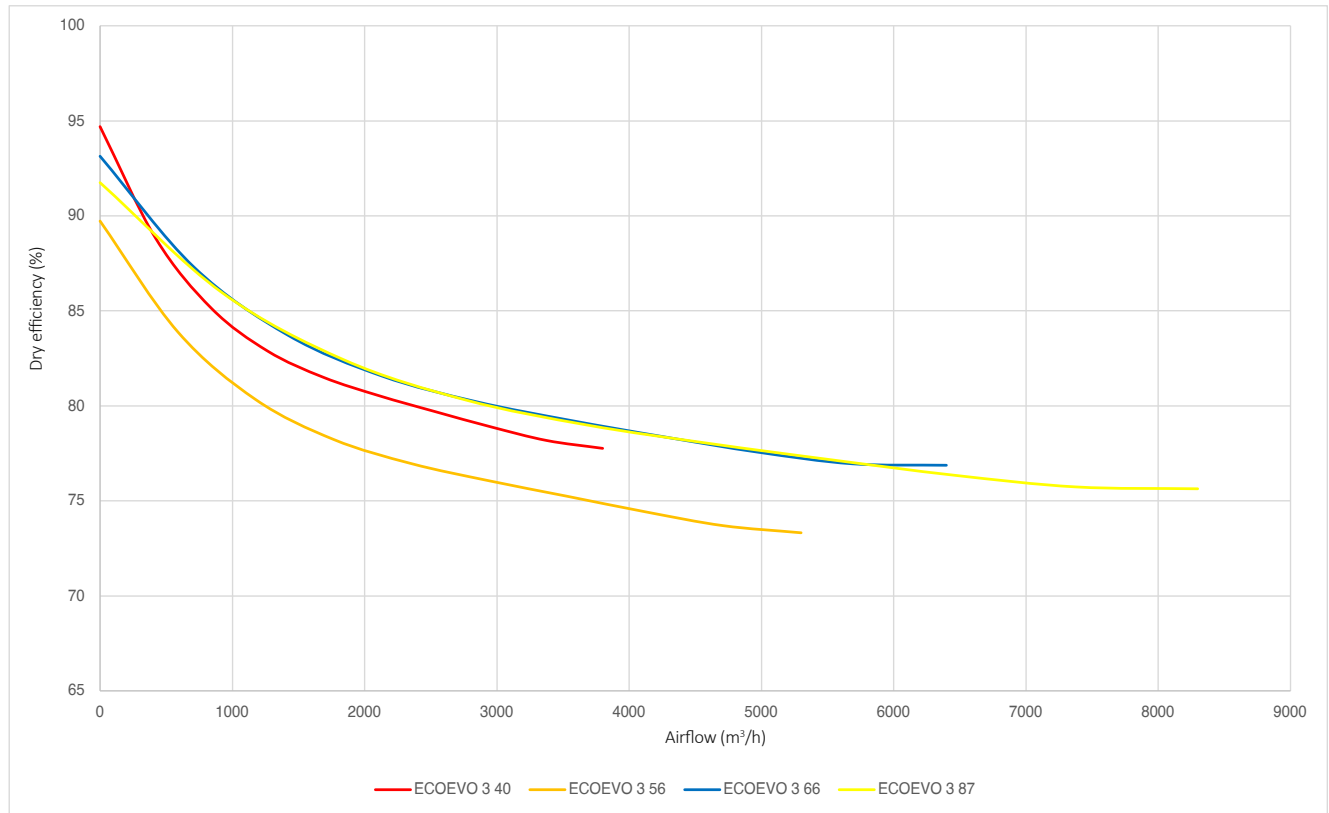

ECOEVO 3 ePM10 50%/M5

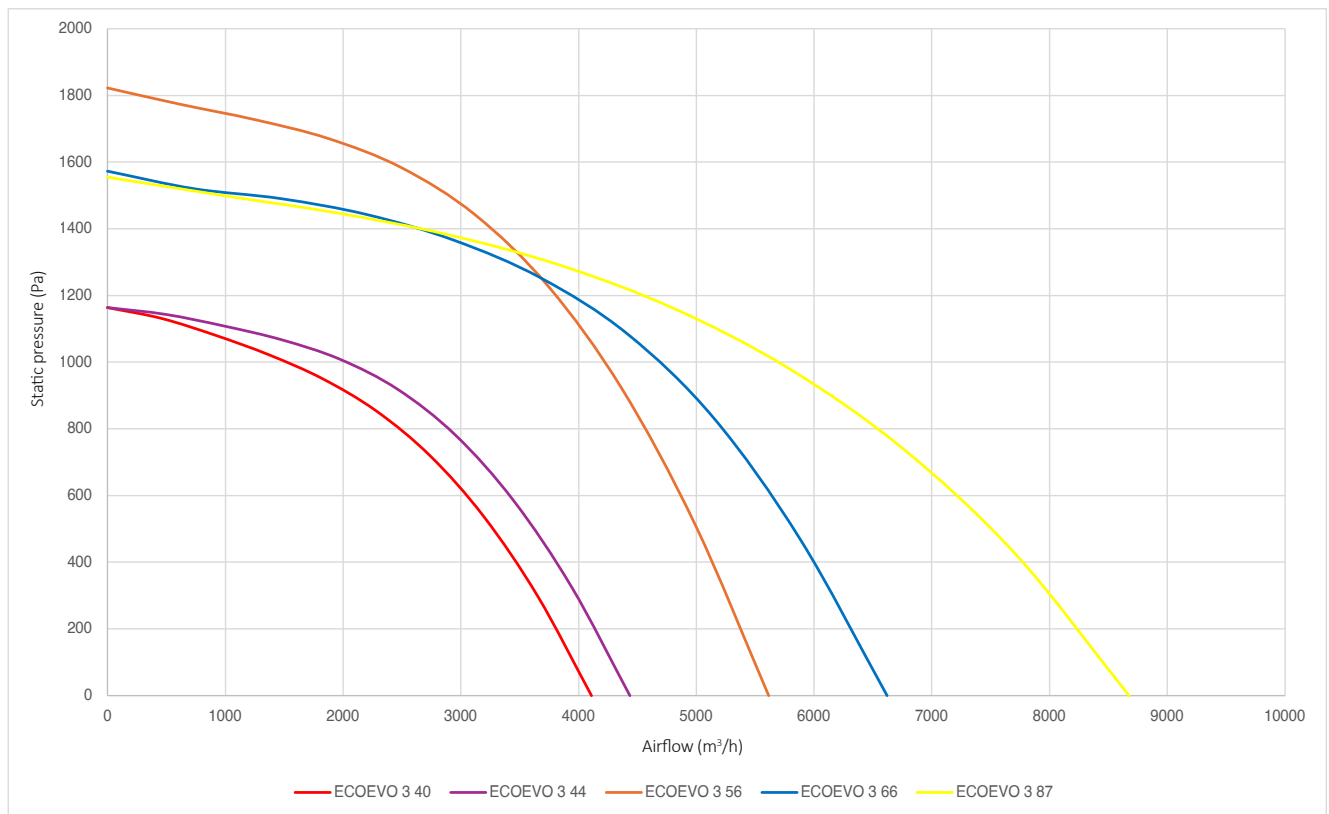



PERFORMANCE CURVES

HEAT RECOVERY

ECOEV0 3 ePM1 50%/F7

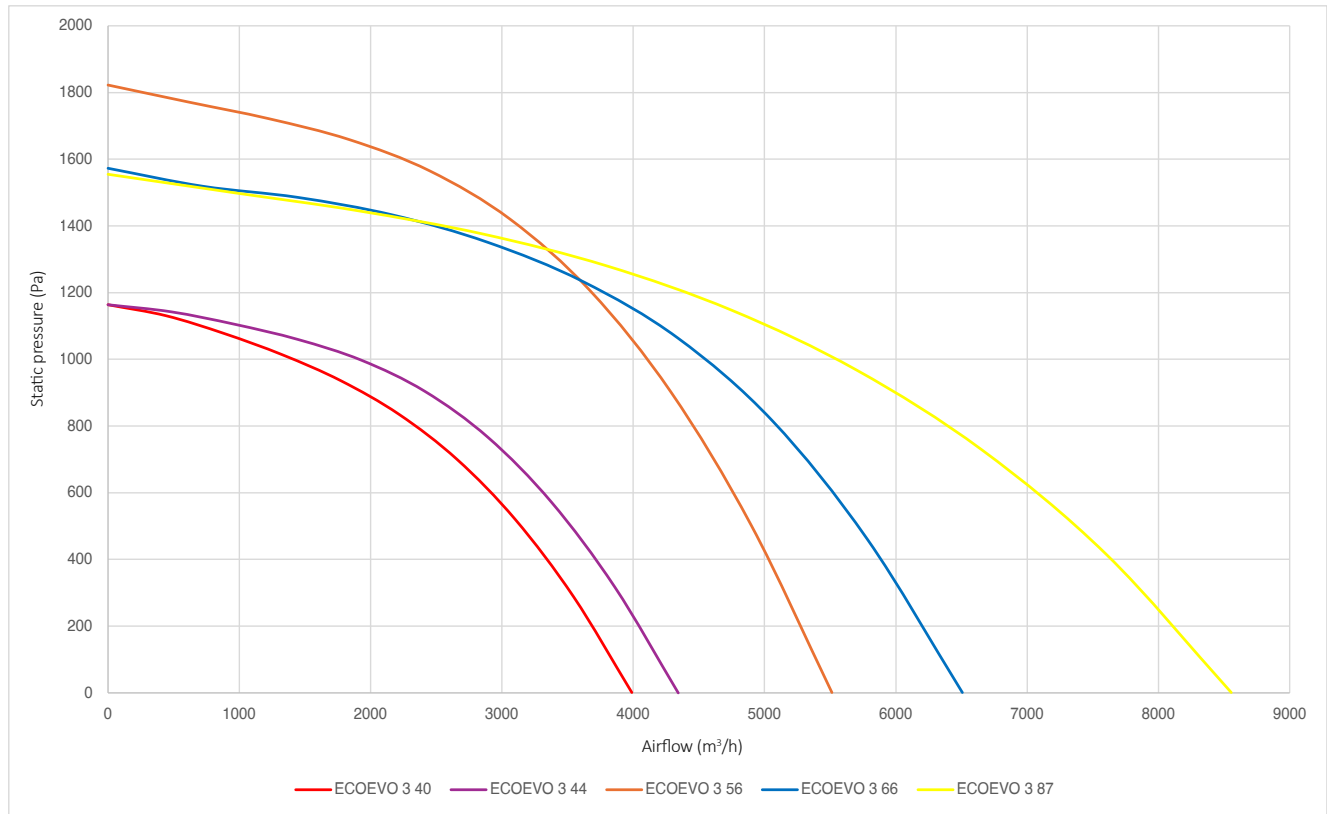

ECOEV0 3 ePM1 80%/F9

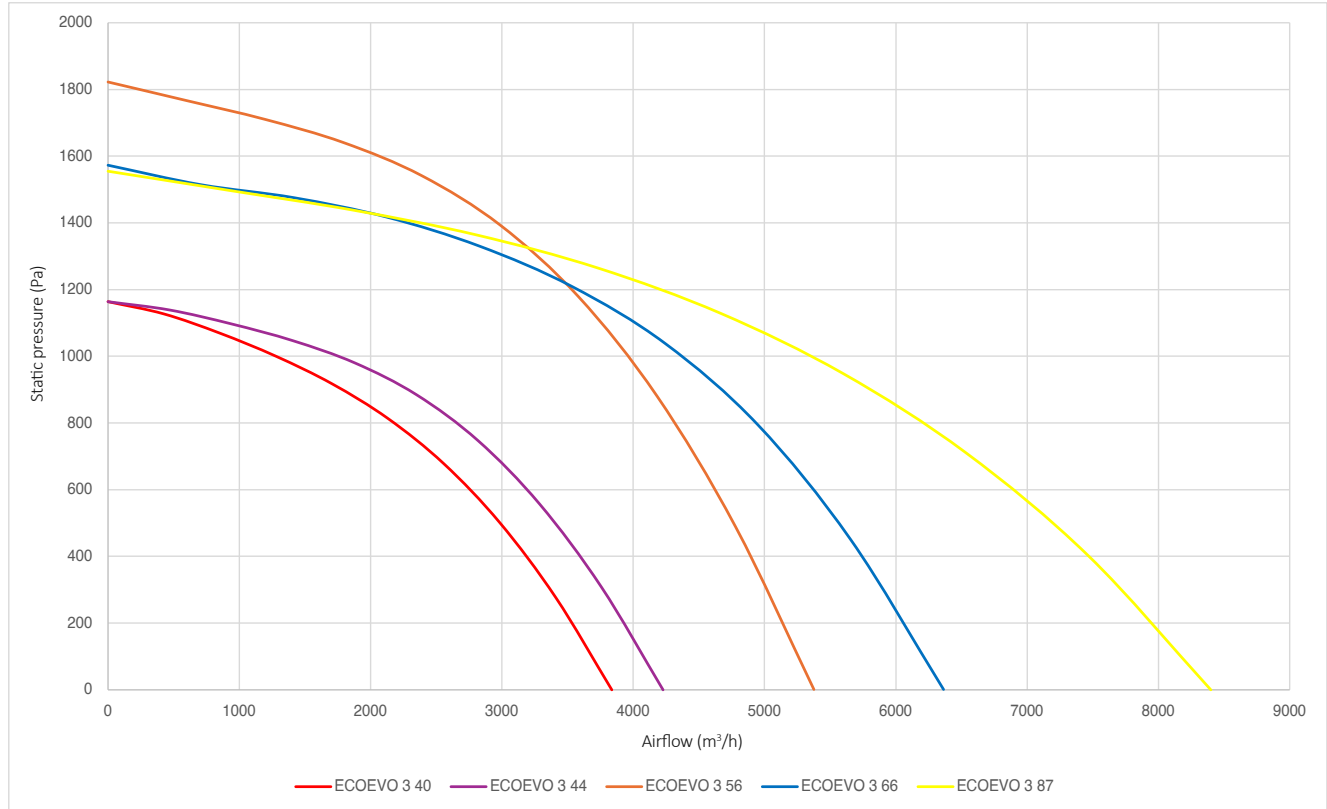

PERFORMANCE CURVES

ECOEVO 3 ePM10 50%/M5 + ePM1 50%/F7

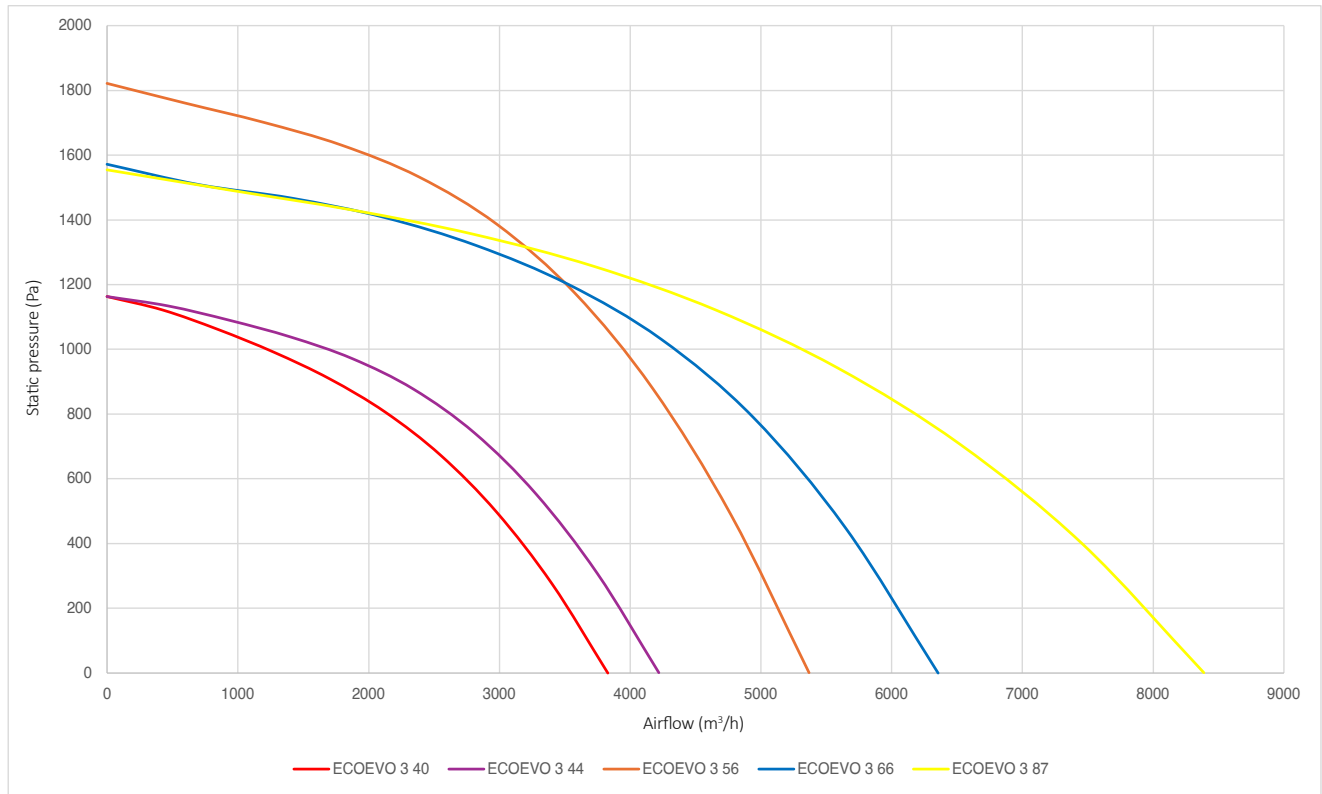

ECOEVO 3 ePM10 50%/M5 + ePM1 80%/F9

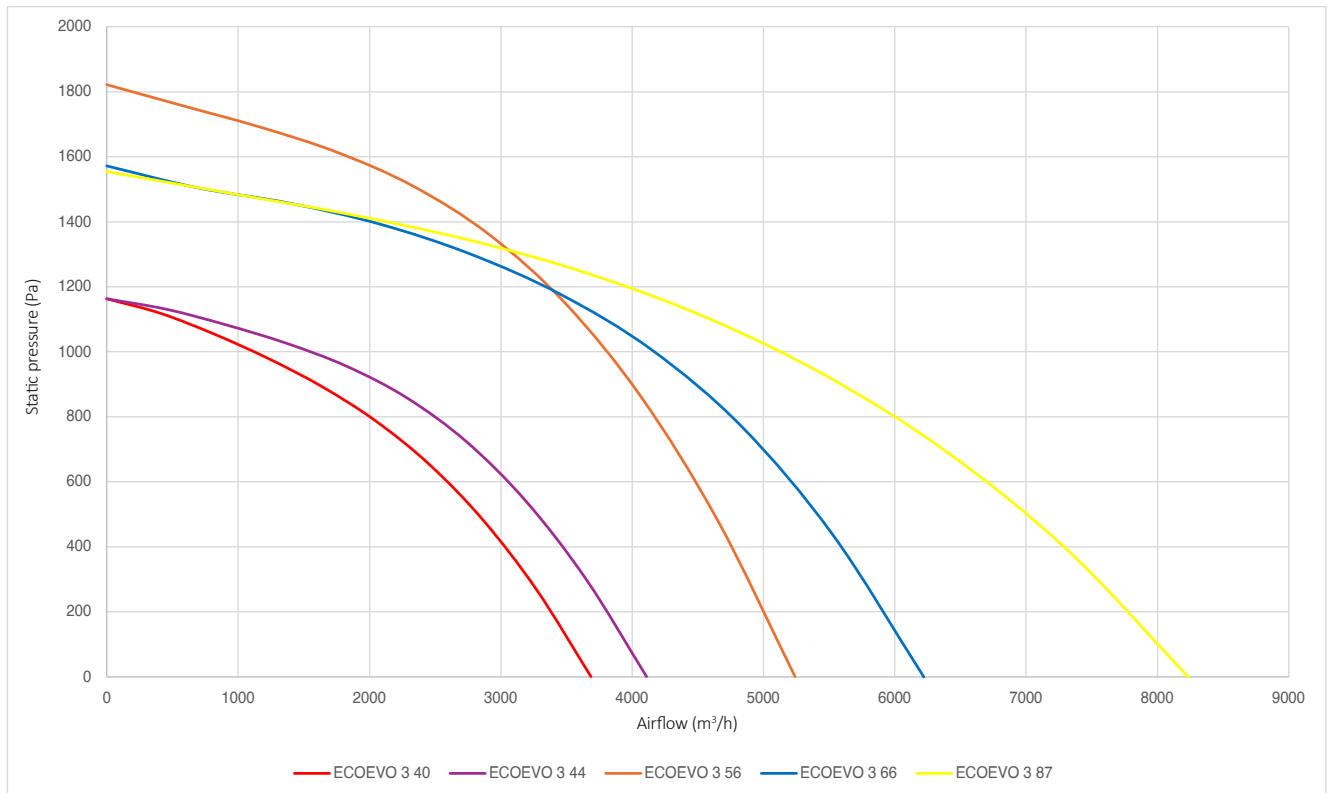



PERFORMANCE CURVES

ECOevo 3 ePM1 50%/F7 + ePM1 80%/F9

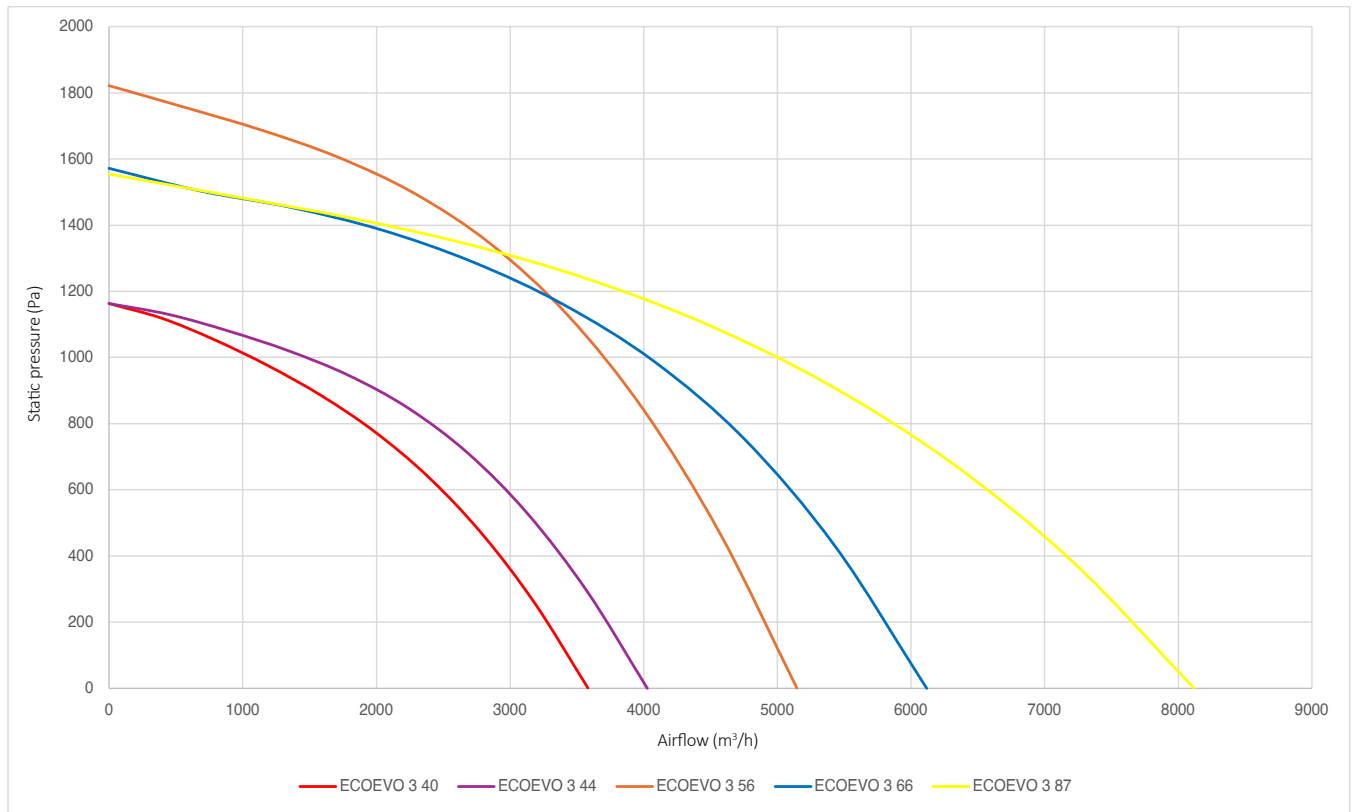

ECOevo 3 WATER HEATING MODULE

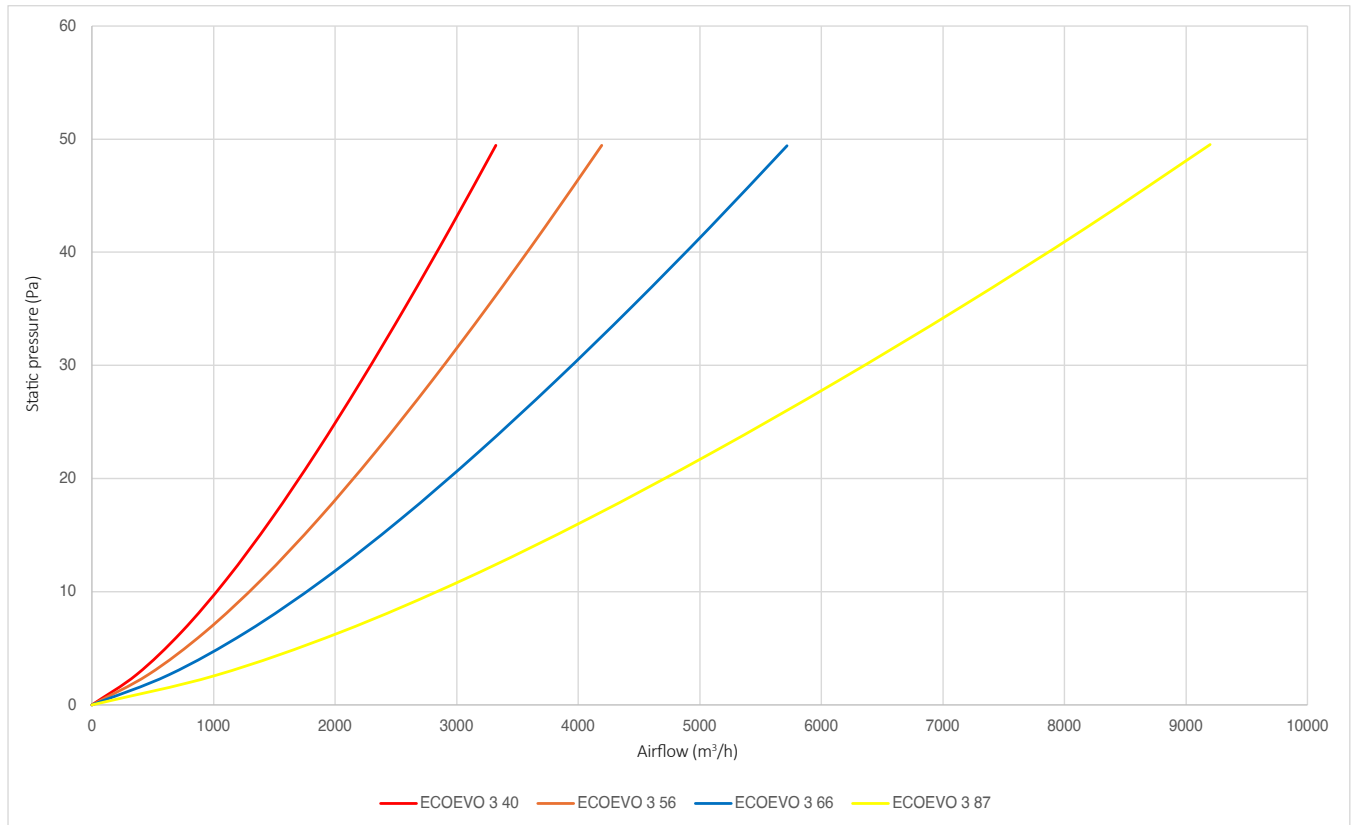



PERFORMANCE CURVES

ECOEVO 3 CHANGE OVER MODULE

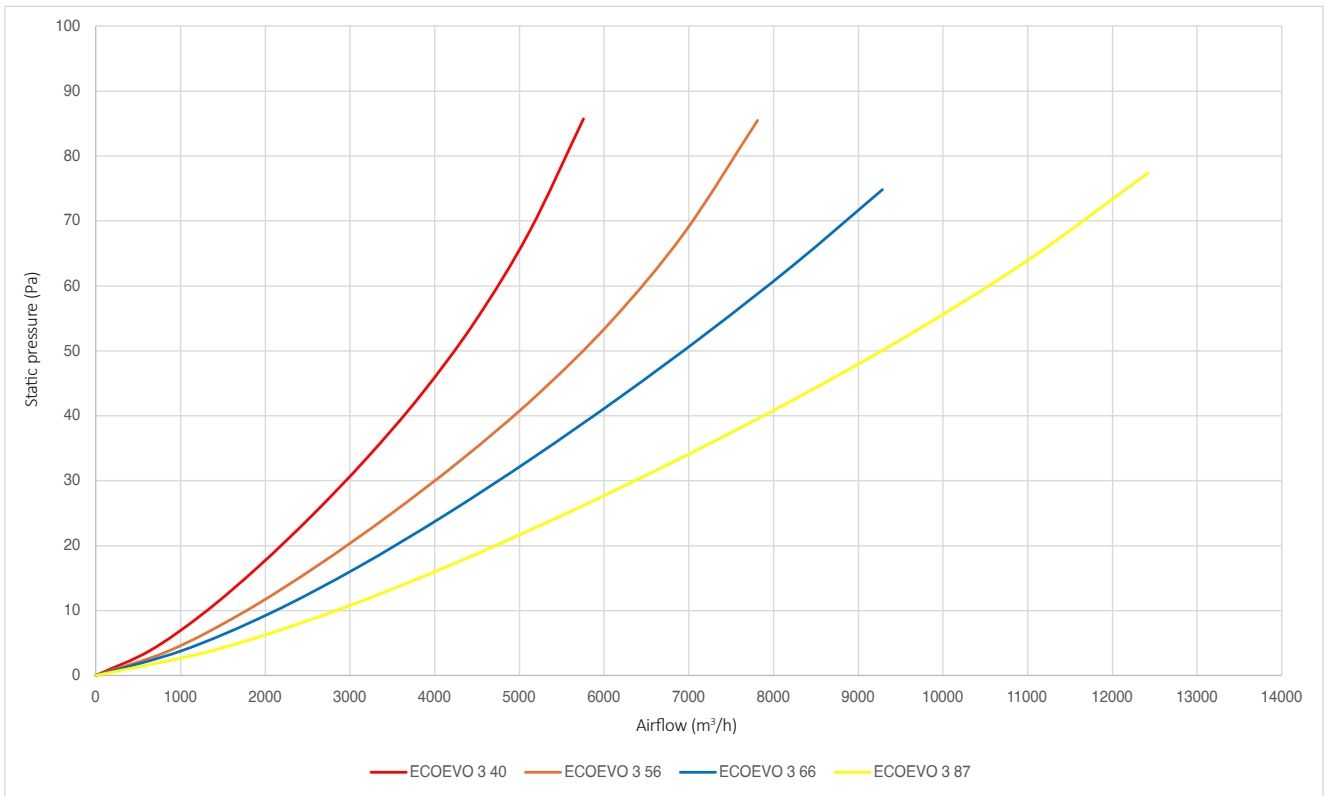

ECOEVO 3 DX MODULE

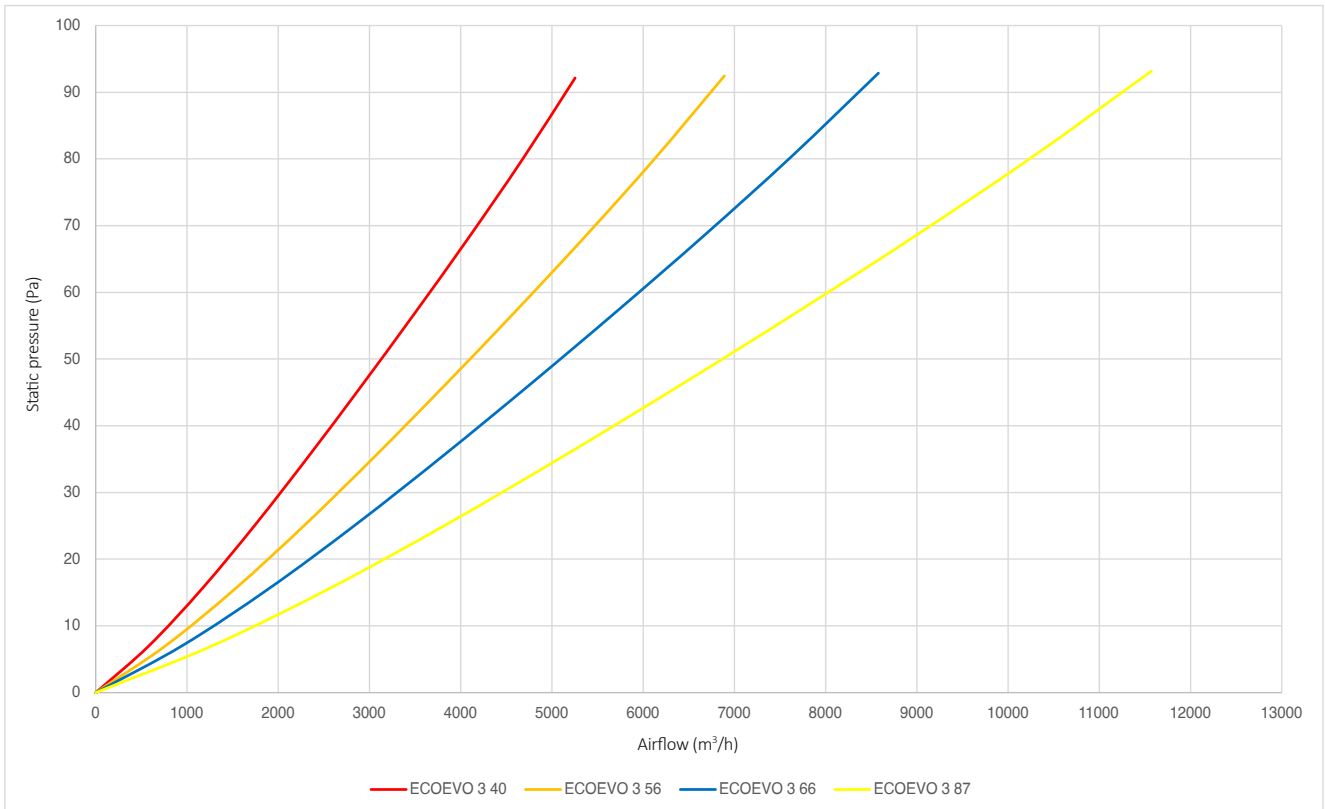

DX COIL - DIRECT EXPANSION COIL



DIMENSIONS

ECCOEVO 3 H	40	44	56	66	87
A (mm)	600	700	700	900	1150
L (mm)	1300	1400	1400	1400	1650
P (mm)	2200	2200	2200	2300	2900
D (mm)	450	500	500	500	630
C (mm)	605	655	655	655	780
H (mm)	540	640	640	840	1090
E (mm)	300	350	350	450	575
Weight (kg)	327	360	365	440	659

ECCOEVO 3 V	40	44	56	66	87
A (mm)	1410	1510	1510	1520	1760
L (mm)	600	700	700	900	1150
P (mm)	2200	2200	2200	2400	3000
D (mm)	450	500	500	500	630
C (mm)	540	640	640	840	1090
H (mm)	660	710	710	715	835
E (mm)	360	385	385	388	448
F (mm)	1050	1125	1125	1133	1313
Weight (kg)	327	360	365	440	659

DIMENSIONS

ECOEVO 3 H

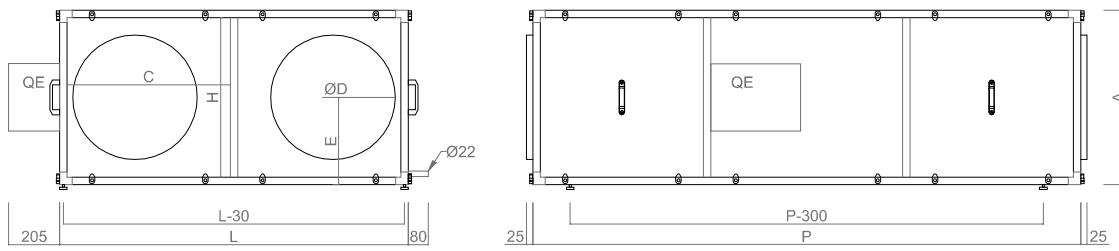

ECOEVO 3 V

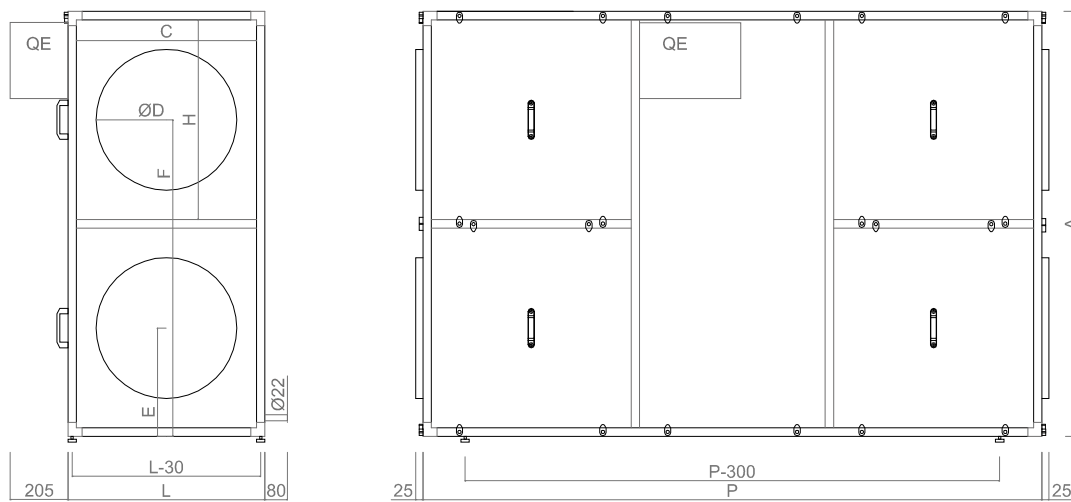

NOTE: MAINTENANCE CLEARANCE AND UNIT ACCESS DISTANCE | 750 MM



DIMENSIONS

WATER HEATING MODULE

ECCOEV0 3 / BAA	40	44	56	66	87
A (mm)	600	700	700	900	1150
L (mm)	725	775	775	775	900
P (mm)	350	350	350	350	350
Ø Hydraulic Connection (pol.)	3/4"	3/4"	3/4"	3/4"	1"
Weight (kg)	37	42	42	50	68

CHANGE OVER MODULE

ECCOEV0 3 / BCA	40	44	56	66	87
A (mm)	600	700	700	900	1150
L (mm)	800	850	850	850	975
P (mm)	865	1030	1030	1190	1205
Ø Hydraulic Connection (pol.)	1"	1 1/4"	1 1/4"	1 1/4"	1 1/2"
Ø Condensate Outlet (mm)			22		
Weight (kg)	99	129	129	157	194

DIRECT EXPANSION MODULE

ECCOEV0 3 / BCR	40	44	56	66	87
A (mm)	600	700	700	900	1150
L (mm)	800	850	850	850	975
P (mm)	865	1030	1030	1190	1205
Ø Liquid (mm)	28	28	28	35	42
Ø Steam (mm)	16	22	22	28	28
Ø Condensate Outlet (mm)			22		
Weight (kg)	98	120	123	152	188

ELECTRIC HEATING MODULE

ECCOEV0 3 / BRE	40	44	56	66	87
A (mm)	600	700	700	900	1150
L (mm)	725	775	775	775	900
P (mm)	350	350	350	350	350
Weight (kg)	29	35	35	43	56

ACOUSTIC ATTENUATION MODULE

ECCOEV0 3 / MAA	40	44	56	66	87
A (mm)	600	700	700	900	1150
L (mm)	650	700	700	700	825
P (mm)	700	700	700	700	700
Weight (kg)	42	54	54	62	75

STANDARD CONFIGURATIONS HORIZONTAL MODEL

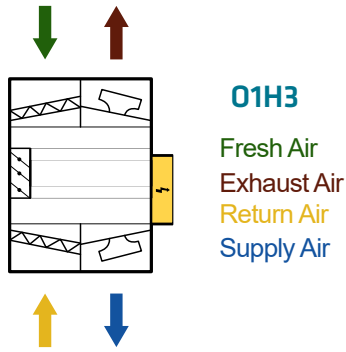

CONFIGURATIONS HORIZONTAL MODEL

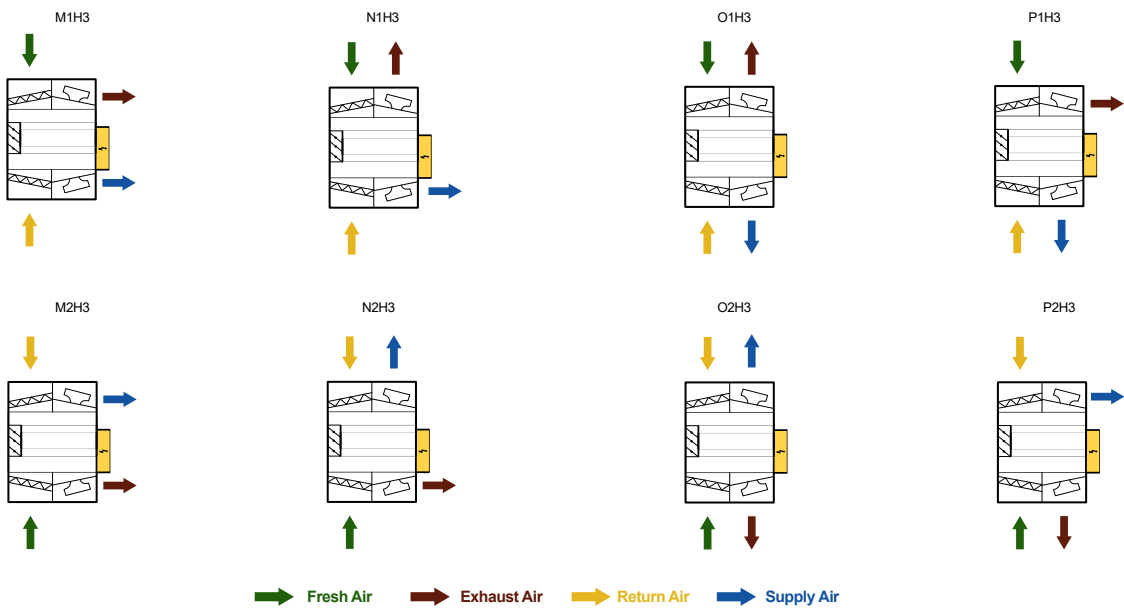

CONFIGURATIONS VERTICAL MODEL

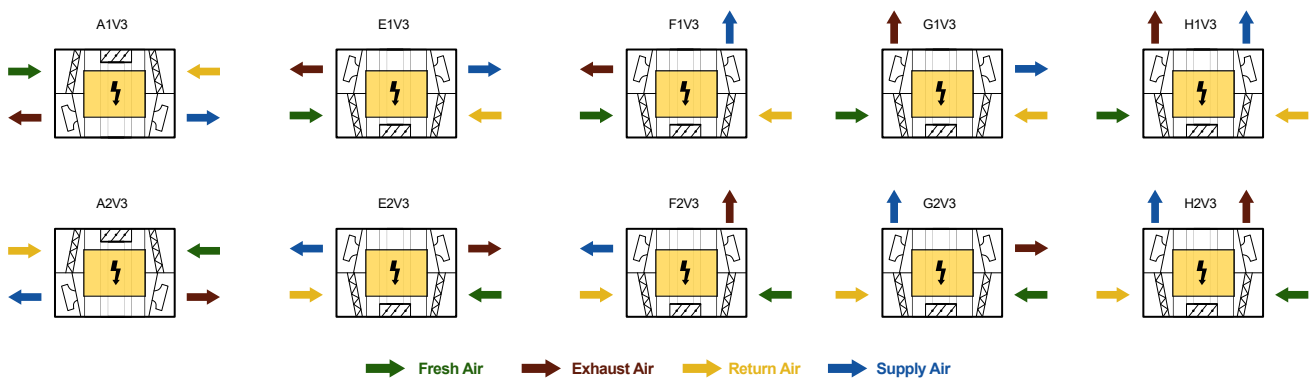

NOTE: FOR VERTICAL MODELS, IT IS NOT POSSIBLE TO INSTALL AN OUTDOOR ROOF IN CONFIGURATIONS F, G, AND H



ERP VERIFICATION DOCUMENT

MANUFACTURER		ARFIT AIR CONDITIONING, S.A.				
Model		40	44	56	66	87
Type		UVNR UVB				
Transmission Type		Variable Speed	Variable Speed	Variable Speed	Variable Speed	Variable Speed
Heat Recovery System Type		OTHER				
Heat Recovery Thermal Efficiency	%	77.2	74.3	73.7	76.7	75.5
Nominal Airflow	m ³ /s	0.986	1.164	1.319	1.7	2.133
Input Power	kW	1.311	1.19	2.381	2.15	3.268
SPFint	W m ² /s	1570.2	1462.6	1421.5	1440.9	1372.9
Frontal Velocity	m/s	6.20	5.93	6.72	8.66	6.85
Nominal External Pressure	Pa	285	107	607	256	385
Decrease in internal pressure ventilation	Pa	499	379	456	421	359
Static Efficiency of Fans	%	59.0	47.6	59.0	53.5	48.6
Maximum Declared Internal/External Leakage Rate	%	4,1/3,8	4,2/3,8	4,1/3,8	4,3/3,9	4,4/4,0
Filter Classification		F7/M5				
Description: Visual notice regarding filters		The filters warning is displayed on the unit's control system, either via a warning light or on-screen message, depending on the control system used. It is of the utmost importance to replace the filters regularly to improve the unit's performance and energy efficiency.				
Sound Power Level (Lwa)	dB(A)	73	74	80	77	85
Website		www.arfit.pt				

ECOevo 2 PLUS

INDEX



Be.On



Plug & Play



EC
Technology



Equipment
with control



High-efficiency
heat recovery
unit



50 mm
panel

DESCRIPTION

Industrial heat recovery unit, ECOevo 2 PLUS model, sound-insulated equipment for indoor or outdoor installation, with removable side panels for easy internal access, available with various accessories and configurations. Supplied as standard with Smart Evolution control and electrical panel equipped with isolating switch.

Modular structure in extruded aluminium profile (6060) according to DIN 17615 with 70 mm thickness and reinforced nylon corners. Double-wall panels with 50 mm thickness, outer face in Magnelis steel with corrosion class C5, inner face in galvanized steel sheet according to EN10192. The intermediate insulation of the panels is filled with self-extinguishing polystyrene boards 50 mm thick, with a density of 30 kg/m³, providing high resistance to different mechanical stresses.

Available in 5 sizes, horizontal or vertical version, with HVAC modules and Smart Evolution or Smart Pro 2 control.

STANDARDS AND CERTIFICATIONS



Class IE4

ADVANTAGES

- Plug & Play monoblock unit.
- High-efficiency heat exchanger with Eurovent certification.
- Panels with 50 mm insulation.
- Corrosion class C5.
- Multiple configurations.
- Possibility of integrating Be.On module with direct cloud connection and Be.Smart monitoring.
- 3-way valve and actuator included.

ACCESSORIES

- ePM10 50% / M5 filter
- ePM1 50% / F7 filter
- ePM1 80% / F9 filter
- Protection for rain
- Rain Roof
- Constant airflow control
- CO₂ Control

COMPONENTS

FAN

Centrifugal fans with directly coupled motor and single-inlet high-efficiency backward-curved impeller, statically and dynamically balanced according to ISO 1940 and AMCA 204-G2.5. The Plug Fan centrifugal fan is directly driven by an EC motor with external rotor and electronic commutation, high efficiency, insulation class F, efficiency class IE4 and IE5, and mechanical protection IP54 and IP55.

FILTERS

Filters of class ePM10 50%/M5, ePM1 50%/F7 or ePM1 80%/F9 according to EN 779 / ISO 16890. Filters are mounted in parallel on rails designed to maintain bypass leakage values within class F9 according to EN 1886.

**HEAT EXCHANGER**

High-efficiency parallel-flow heat exchangers with bypass. Allow recovery of sensible heat from exhaust air to supply air with efficiencies up to 96% (Eurovent certified). Constructed with stamped aluminium plates of 0.3 mm thickness, with double-fold edges at plate junctions ensuring airtightness up to 1500 Pa.

COMPLEMENTARY MODULES

To complement the heat recovery range, in addition to standard accessories, a series of optional modules is available. These modules are externally connected to the unit via ductwork.

WATER HEATING MODULE

Water heating coil composed of copper tubes with aluminium fins fixed by mechanical expansion, steel or copper headers and galvanized steel structure. Factory tested at 32 bar to ensure tightness and integrity. Includes 3-way valve and actuator.

CHANGE OVER MODULE

Water cooling/heating coil composed of copper tubes with aluminium fins mechanically expanded, steel or copper headers and galvanized steel structure. All coils are subject to rigorous testing, with tightness and integrity verified at 32 bar. Module equipped with stainless steel condensate tray. Includes 3-way valve and actuator.

ACOUSTIC ATTENUATION MODULE

Baffles made of mineral wool, with air-contact surface in non-fragmenting material, protected by mesh or micro-perforated sheet, with galvanized steel frame.

DIRECT EXPANSION MODULE

Direct expansion coil for R410A refrigerant, composed of copper tubes with aluminium fins mechanically expanded, steel or copper headers and galvanized steel structure. All coils are rigorously tested, with tightness and integrity verified at 60 bar. Module equipped with stainless steel condensate tray.

**ELECTRIC HEATING MODULE**

Electric finned heating elements in 8 mm diameter steel tube with 25 x 50 mm fins of the same material, with quick-fix screw and M4 threaded terminals. Designed for air handling applications. Mounted in frame and placed on rails for easy removal.

CHARACTERISTICS

ECOEVO 2 PLUS	11	18	25	42	56
Motor Power (kW)	2 x 0,17	2 x 0,50	2 x 0,50	2 x 1,30	2 x 1,4
Power Supply (V F Hz)	230 1 50				
IMAX (A)	2,9	5,1	4,5	13,3	12,1
Sound Pressure (dB(A)) *	29	39	36	40	41

* Sound pressure level at 4 m, measured in open field according to ISO 3744



COMPLEMENTARY MODULES

WATER HEATING MODULE

Model	Airflow (m ³ /h)	Air inlet temperature (°C)	Air outlet temperature (°C)	Heating capacity (kW)	Air pressure drop (Pa)	Water flow rate (l/s)	Water pressure drop (kPa)
ECOevo 2 PLUS 11	1000	5	27,6	8,4	116	0,1	4,7
		10	30,6	7,7		0,094	4
		15	33,6	7		0,085	3,3
	900	5	29,6	7,5	79	0,091	3,8
		10	32,5	6,8		0,083	3,2
		15	35,3	6,2		0,076	2,7
	700	5	32,3	6,4	50	0,079	2,9
		10	34,9	5,9		0,072	2,5
		15	37,4	5,3		0,065	2,1
ECOevo 2 PLUS 18	1800	5	31,4	16	63	0,2	5,1
		10	34,1	14,7		0,18	4,4
		15	36,8	13,3		0,16	3,7
	1550	5	33	16,6	48	0,18	4,4
		10	35,6	13,4		0,16	3,7
		15	38,1	12,1		0,15	3,1
	1300	5	34,9	13,1	35	0,16	3,6
		10	37,3	12		0,15	3,1
		15	39,7	10,9		0,13	2,6
ECOevo 2 PLUS 25	2500	5	28	19,4	115	0,24	7,2
		10	31	17,8		0,22	6,2
		15	34	16,1		0,2	5,2
	2200	5	29,3	18	91	0,22	6,3
		10	32,2	16,5		0,2	5,4
		15	35,1	15		0,18	4,5
	1900	5	30,8	16,6	70	0,2	5,4
		10	33,6	15,2		0,18	4,6
		15	36,3	13,7		0,17	3,9
ECOevo 2 PLUS 42	4200	5	27,7	32,1	150	0,39	22,4
		10	30,7	29,5		0,36	19,2
		15	33,8	26,8		0,33	16,2
	3800	5	28,6	30,3	125	0,37	20,2
		10	31,7	27,9		0,34	17,3
		15	34,7	25,4		0,31	14,6
	3200	5	30,4	27,5	90	0,34	16,9
		10	33,3	25,2		0,31	14,5
		15	36,2	23		0,28	12,2
ECOevo 2 PLUS 56	5600	5	28	43,4	129	0,53	11,4
		10	31	29,8		0,49	9,7
		15	34,1	26,2		0,44	8,2
	4900	5	39,3	40,3	101	0,49	9,9
		10	32,3	36,9		0,45	8,5
		15	35,2	33,6		0,41	7,1
	4400	5	30,5	37,8	83	0,46	8,8
		10	33,3	34,7		0,42	7,6
		15	36,1	31,5		0,38	6,4

Water temperature 80°C / 60°C



COMPLEMENTARY MODULES

CHANGE OVER MODULE

Heating mode Model	Airflow (m ³ /h)	Air inlet temperature (°C)	Air outlet temperature (°C)	Heating capacity (kW)	Air pressure drop (Pa)	Water flow rate (l/s)	Water pressure drop (kPa)
ECOevo 2 PLUS 11	1000	5	31,4	9,8	34	0,47	7
		10	32,7	8,5		0,41	5,4
		15	34	7,1		0,34	3,9
	900	5	32,8	8,5	25	0,41	5,4
		10	33,9	7,3		0,35	4,1
		15	35	6,1		0,29	3
	700	5	34,5	7	17	0,34	3,8
		10	35,4	6		0,29	2,9
		15	36,2	5		0,24	2,1
ECOevo 2 PLUS 18	1800	5	31,8	16,3	35	0,79	17,9
		10	33,1	14,1		0,68	13,8
		15	34,4	11,8		0,57	10,1
	1550	5	32,8	14,6	29	0,7	14,7
		10	34	12,6		0,61	11,3
		15	35,2	10,6		0,51	8,3
	1300	5	34,1	12,7	22	0,62	11,5
		10	35,1	11		0,53	8,9
		15	36,1	9,3		0,45	6,5
ECOevo 2 PLUS 25	2500	5	32,3	23	33	1,11	7,2
		10	33,6	20		0,96	6,2
		15	34,8	16,8		0,81	5,2
	2200	5	33,2	20,9	28	1,01	6,3
		10	34,3	18,1		0,88	5,4
		15	35,5	15,3		0,74	4,5
	1900	5	34,2	18,7	22	0,9	5,4
		10	35,2	16,2		0,78	4,6
		15	26,2	13,7		0,66	3,9
ECOevo 2 PLUS 42	4200	5	30,5	36,1	45	1,74	14,7
		10	31,9	31,2		1,51	11,3
		15	33,4	26,2		1,27	8,3
	3800	5	31,2	33,6	39	1,62	12,9
		10	32,6	29		1,4	9,9
		15	33,9	24,4		1,2	7,3
	3200	5	32,4	29,6	38	1,43	10,3
		10	33,6	25,6		1,24	7,9
		15	34,8	21,6		1,04	5,8
ECOevo 2 PLUS 56	5600	5	31,5	50,1	38	2,42	21
		10	32,8	43,3		2,09	16,1
		15	34,2	36,5		1,76	11,8
	4900	5	32,4	45,4	32	2,19	17,6
		10	33,7	39,3		1,9	13,5
		15	34,9	33,1		1,6	9,9
	4400	5	33,2	41,9	27	2,02	15,2
		10	34,3	36,2		1,75	11,7
		15	35,5	30,6		1,48	8,6

Water temperature in Heating mode 45°C / 40°C

COMPLEMENTARY MODULES

CHANGE OVER MODULE

Cooling mode Model	Airflow (m ³ /h)	Air inlet temperature (°C)	Air outlet temperature (°C)	Cooling capacity (kW)	Air pressure drop (Pa)	Water flow rate (l/s)	Water pressure drop (kPa)
ECOevo 2 PLUS 11	1100	31	20,8	6	48	0,28	3,4
		28	19,4	4,1		0,19	1,7
		25	18,1	2,6		0,12	0,8
	900	31	20,2	5,1	36	0,24	2,6
		28	19,5	3,1		0,15	1,1
		25	17,4	2,4		0,11	0,7
	700	31	19,6	4,2	24	0,2	1,8
		28	18,5	2,8		0,13	0,9
		25	16,6	2,1		0,1	0,6
ECOevo 2 PLUS 18	1800	31	20,1	11	53	0,53	10,3
		28	18,3	8,3		0,4	6,3
		25	16,8	5,8		0,28	3,3
	1550	31	19,6	10	42	0,48	8,6
		28	17,9	7,5		0,36	5,2
		25	16,6	5,1		0,24	2,6
	1300	31	19	8,8	33	0,42	0,9
		28	17,4	6,6		0,31	4,1
		25	16,4	4,4		0,21	2
ECOevo 2 PLUS 25	2500	31	19,7	16,2	50	0,77	13,2
		28	17,9	12,4		0,59	8,3
		25	16,3	8,9		0,42	4,6
	2200	31	19,2	14,8	42	0,71	11,4
		28	17,5	11,4		0,5	7,1
		25	16,1	8,1		0,38	3,9
	1900	31	18,7	13,4	34	0,64	9,5
		28	17,1	10,2		0,49	5,9
		25	15,7	7,2		0,34	3,2
ECOevo 2 PLUS 42	4200	5	20,8	23,9	68	1,14	8,1
		10	18,9	18		0,86	4,9
		15	17,3	12,4		0,59	2,5
	3800	5	20,5	22,4	58	1,07	7,2
		10	18,6	16,8		0,8	4,3
		15	19,2	11,4		0,55	2,2
	3200	5	19,9	19,9	45	0,95	5,9
		10	18,2	14,9		0,71	3,5
		15	16,9	9,9		0,47	1,7
ECOevo 2 PLUS 56	5600	31	20,3	33,8	58	1,61	10,1
		28	18,5	25,6		1,22	6,2
		25	16,9	17,9		0,85	3,3
	4900	31	19,8	30,9	47	1,47	8,6
		28	18,1	23,4		1,11	5,2
		25	16,6	16,1		0,77	2,7
	4400	31	19,4	28,8	40	1,37	7,6
		28	17,8	21,6		1,03	4,6
		25	16,5	14,8		0,7	2,3

Water temperature em Cooling mode 7°C / 12°C; Air humidity 50%



COMPLEMENTARY MODULES

DIRECT EXPANSION MODULE

Heating mode Model	Airflow (m³/h)	Air inlet temperature (°C)	Air outlet temperature (°C)	Heating power (kW)	Air pressure drop (Pa)
ECOEV0 2 PLUS 11	1100	5	22,7	6,6	46
		10	24,9	5,6	
		15	27,2	4,6	
	900	5	24,1	5,8	32
		10	26,2	5	
		15	28,2	4,1	
	700	5	25,9	5	20
		10	27,7	4,2	
		15	29,5	3,5	
ECOEV0 2 PLUS 18	1800	5	25	12,3	45
		10	27,2	10,5	
		15	29,3	8,8	
	1550	5	26,2	11,2	35
		10	28,1	9,6	
		15	30,1	8	
	1300	5	27,6	10	25
		10	29,3	8,6	
		15	31,1	7,2	
ECOEV0 2 PLUS 25	2500	5	26,1	17,9	37
		10	28,1	15,4	
		15	30,1	12,9	
	2200	5	27,1	16,5	30
		10	29	14,2	
		15	30,8	11,9	
	1900	5	28,2	15	23
		10	30	12,9	
		15	31,7	10,8	
ECOEV0 2 PLUS 42	4200	5	22,9	25,5	53
		10	25,2	21,7	
		15	27,4	17,9	
	3800	5	23,7	24,1	44
		10	25,8	20,5	
		15	27,9	16,8	
	3200	5	24,9	21,7	33
		10	26,9	18,4	
		15	28,8	15,2	
ECOEV0 2 PLUS 56	5600	5	25,4	38,7	42
		10	27,4	33,3	
		15	29,5	27,8	
	4900	5	26,4	35,6	33
		10	28,3	30,6	
		15	30,3	25,6	
	4400	5	27,2	33,2	27
		10	29,1	28,6	
		15	30,9	23,9	

Condensing temperature 50°C

COMPLEMENTARY MODULES
DIRECT EXPANSION MODULE

Cooling mode Model	Airflow (m ³ /h)	Air inlet temperature (°C)	Air outlet temperature (°C)	Cooling capacity (kW)	Air pressure drop (Pa)
ECOEV0 2 PLUS 11	1000	31	19,4	5,8	96
		28	17,5	4,7	
		25	15,6	3,7	
	800	31	18,7	5	68
		28	16,9	4	
		25	15,1	3,2	
	600	31	17,8	4,1	43
		28	16,1	3,3	
		25	14,4	2,6	
ECOEV0 2 PLUS 18	1300	31	18,4	8,4	66
		28	16,6	6,8	
		25	14,8	5,4	
	1050	31	17,7	7,3	47
		28	15,9	5,9	
		25	14,2	4,7	
	800	31	16,8	6,1	30
		28	15,2	4,9	
		25	13,6	3,9	
ECOEV0 2 PLUS 25	2500	31	19,1	15	92
		28	17,2	12,2	
		25	15,4	9,4	
	2200	31	18,7	13,9	75
		28	16,8	11,2	
		25	15	8,8	
	1900	31	18,2	12,6	60
		28	16,4	10,2	
		25	14,6	8	
ECOEV0 2 PLUS 42	3400	31	19,3	16	91
		28	17,4	12,3	
		25	15,6	18,9	
	3100	31	19	15,1	79
		28	17,1	11,8	
		25	15,3	17,7	
	2800	31	18,7	14,3	67
		28	16,8	11	
		25	15,1	-	
ECOEV0 2 PLUS 56	5200	31	19,1	31,1	91
		28	17,3	24,8	
		25	14,5	16,3	
	4800	31	18,9	26,9	80
		28	17,1	23,7	
		25	15,3	18,4	
	4400	31	18,6	28	70
		28	16,8	22,6	
		25	17,4	17,4	

Evaporation temperature 5°C; Air humidity 50%



COMPLEMENTARY MODULES

ELECTRIC HEATING MODULE

Model	Airflow (m³/h)	Air inlet temperature (°C)	Air outlet temperature (°C)	Heating capacity (kW)	Air pressure drop (Pa)
ECOevo 2 PLUS 11	1100	5	21,2	6	2
		10	26,2		
		15	31,2		
	900	5	24,8		
		10	29,8		
		15	34,8		
	700	5	30,4		
		10	35,4		
		15	40,4		
ECOevo 2 PLUS 18	1800	5	24,8	12	2
		10	29,8		
		15	34,8		
	1550	5	28,0		
		10	33,0		
		15	38,0		
	1300	5	32,4		
		10	37,4		
		15	42,4		
ECOevo 2 PLUS 25	2500	5	19,2	12	2
		10	24,2		
		15	29,2		
	2200	5	21,2		
		10	26,2		
		15	31,2		
	1900	5	23,7		
		10	28,7		
		15	33,7		
ECOevo 2 PLUS 42	4200	5	17,7	0	2
		10	22,7		
		15	27,7		
	3800	5	19,1		
		10	24,1		
		15	29,1		
	3200	5	21,7		
		10	26,7		
		15	31,7		
ECOevo 2 PLUS 56	5600	5	19,3	27	3
		10	24,3		
		15	29,3		
	4900	5	21,4		
		10	26,4		
		15	31,4		
	4400	5	23,2		
		10	28,2		
		15	33,2		

COMPLEMENTARY MODULES

ACOUSTIC ATTENUATION MODULE

Model	Airflow	Air pressure drop (Pa)	Acoustic attenuation - Frequency (Hz)								
			63	125	250	500	1000	2000	4000	8000	Total dB(A)
ECOevo 2 PLUS 11	1100	13	3	8	13	19	28	29	22	20	22
	900	11									
	700	5									
ECOevo 2 PLUS 18	1800	30	3	8	13	19	28	29	22	20	22
	1550	24									
	1300	14									
ECOevo 2 PLUS 25	2500	25	2	7	12	17	25	25	19	6	21
	2200	19									
	1900	16									
ECOevo 2 PLUS 42	4200	33	2	7	12	17	25	25	19	16	21
	3800	29									
	3200	24									
ECOevo 2 PLUS 56	5600	40	2	7	12	17	25	25	19	16	21
	4900	33									
	4400	28									

PERFORMANCE CURVES

RECOVERY EFFICIENCY CURVE

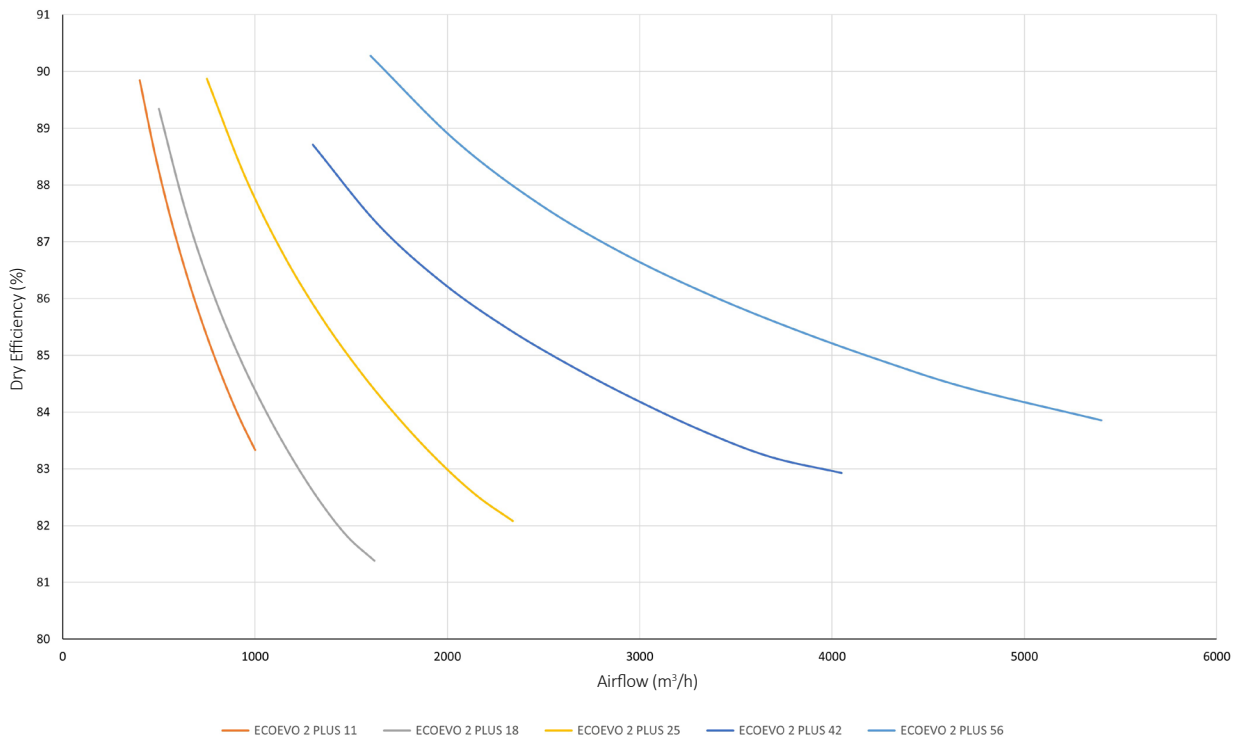

ECOEVO 2 PLUS ePM10 50% /M5

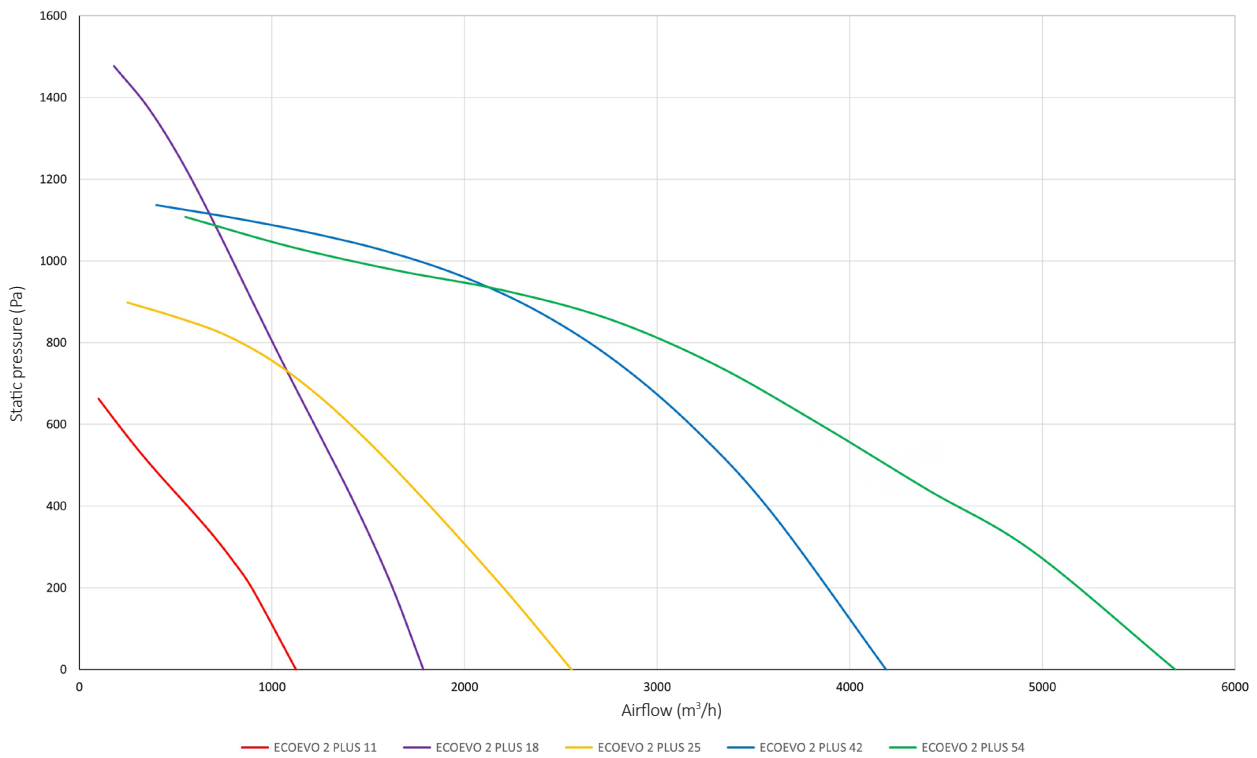



PERFORMANCE CURVES

ECOevo 2 PLUS ePM1 50%/F7

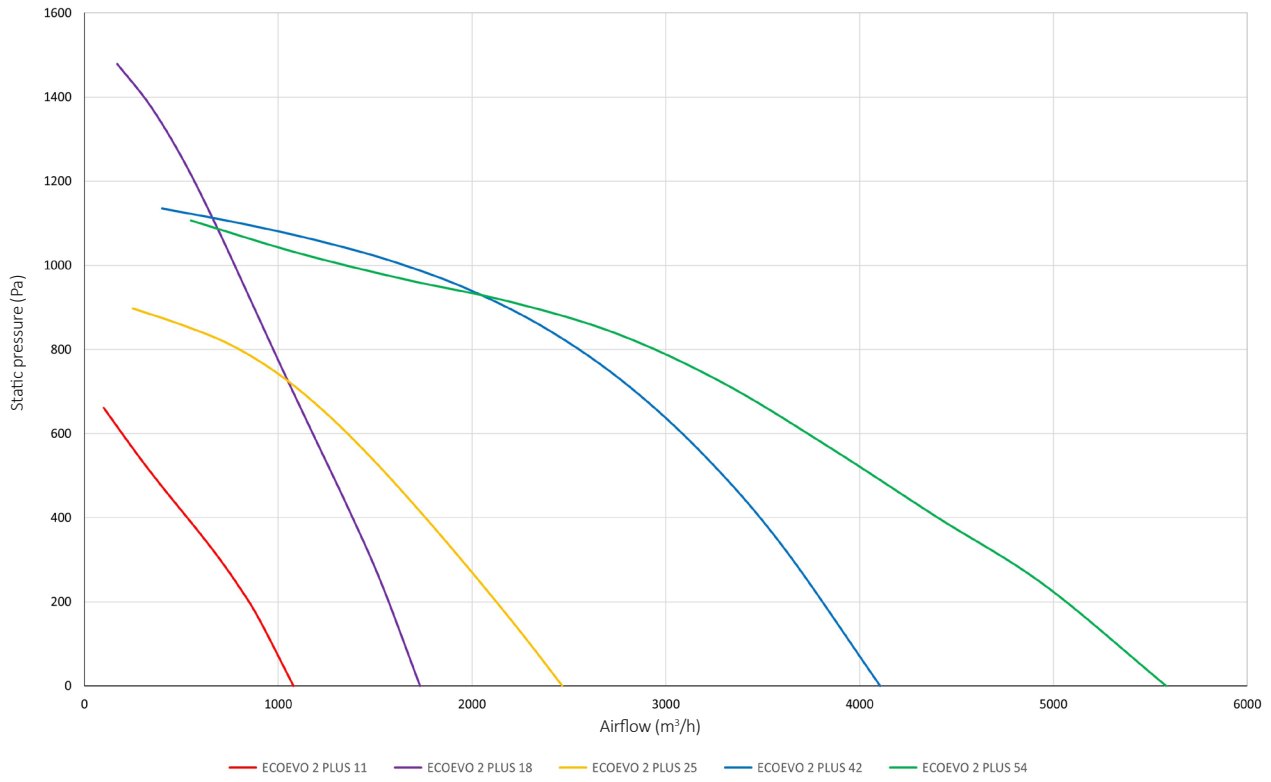

ECOevo 2 PLUS ePM10 50%/M5 + ePM1 50%/F7

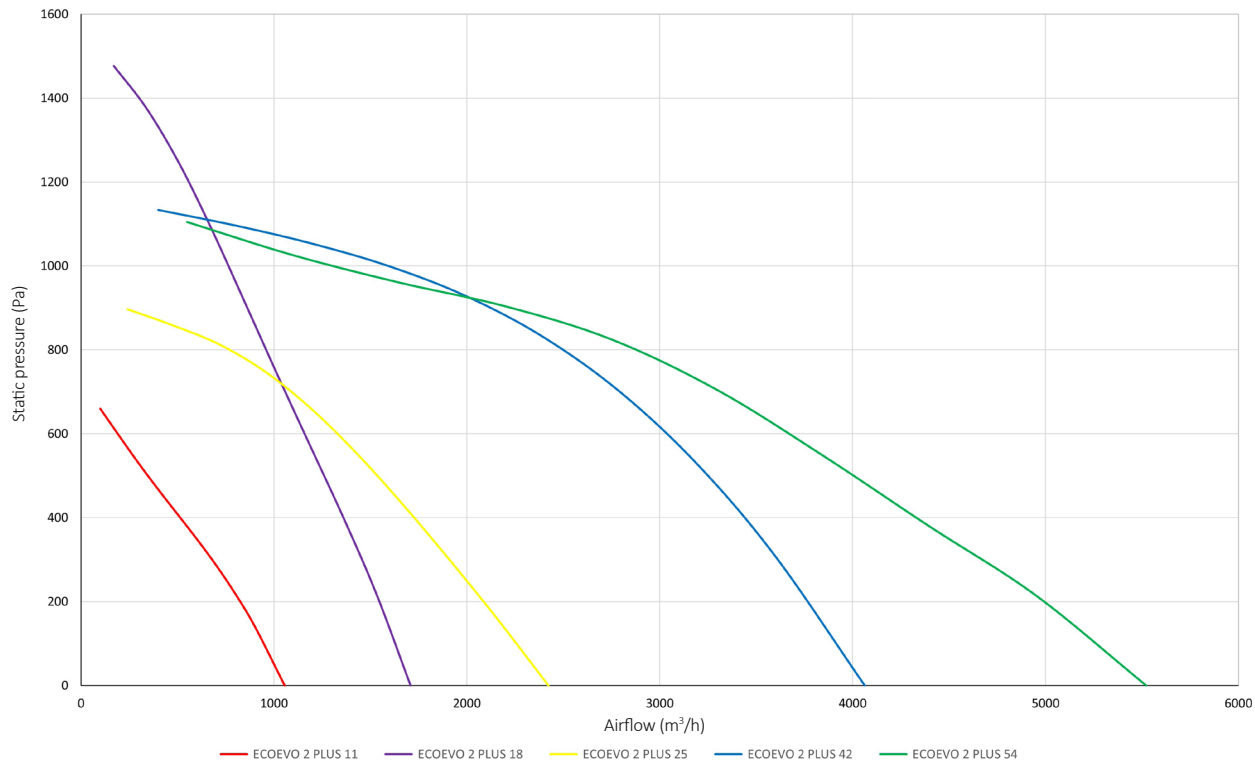

PERFORMANCE CURVES

ECOEVO 2 PLUS ePM10 50%/M5 + ePM1 80%/F9

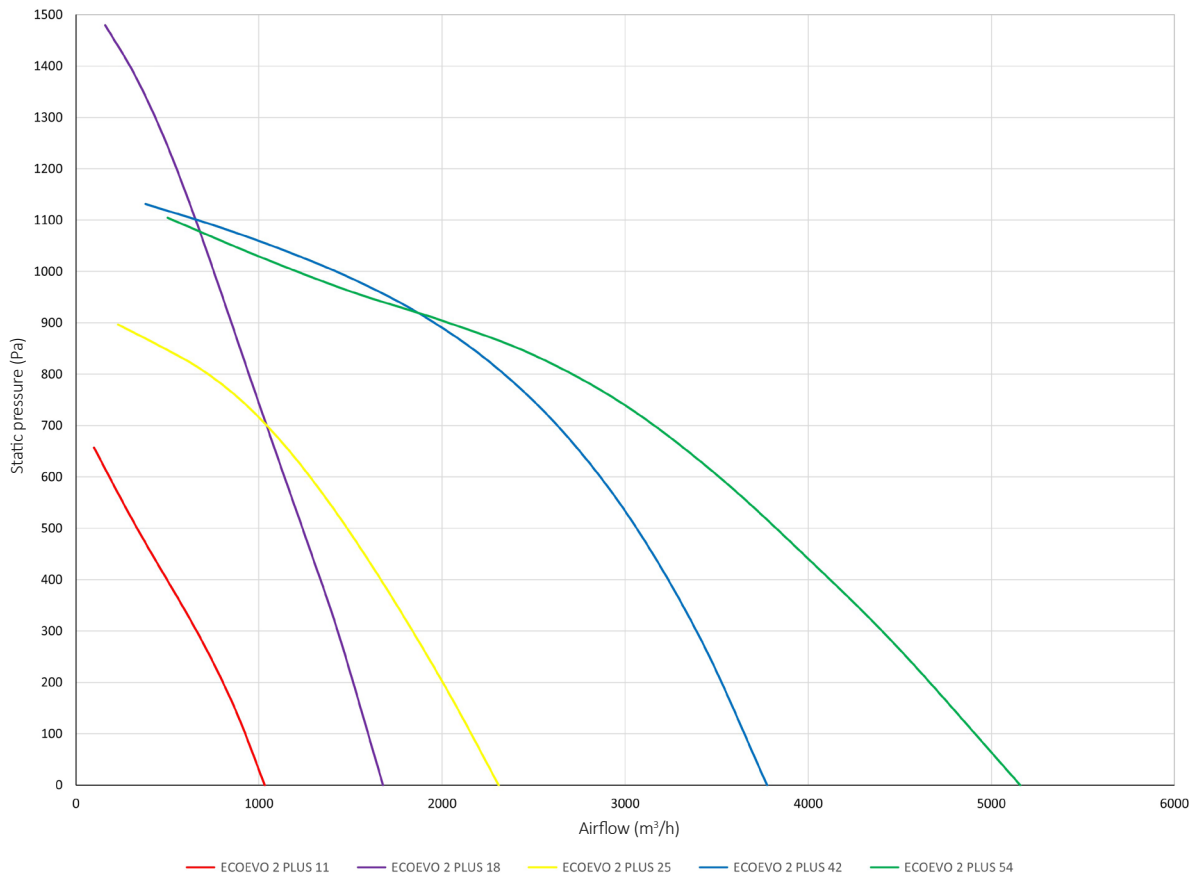

ECOEVO 2 PLUS ePM1 50%/F7 + ePM1 80%/F9

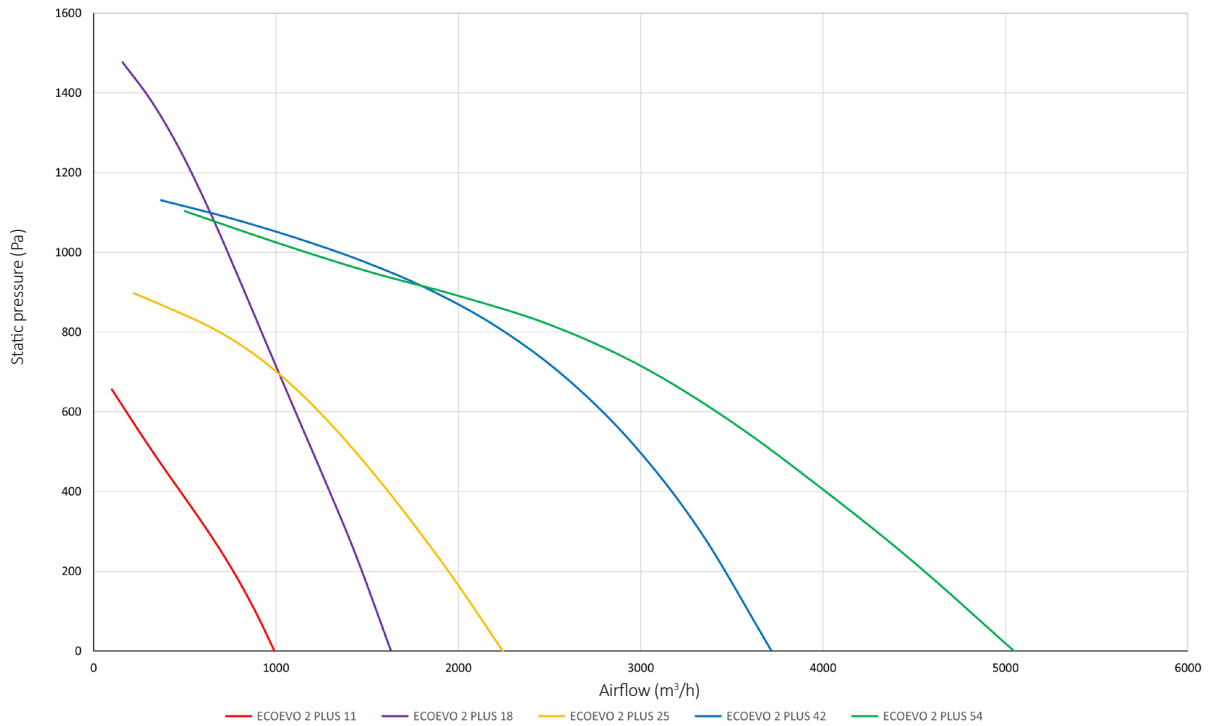



DIMENSIONS

ECOEVO 2 PLUS H	11	18	25	42	56
A (mm)	545	580	580	730	865
L (mm)	910	1050	1500	1650	1790
P (mm)	1550	1750	1950	2250	2650
ØD (mm)	315	355	355	450	450
E (mm)	273	290	290	365	433
Weight (kg)	92	156	217	268	296
ECOEVO 2 PLUS V	11	18	25	42	56
A (mm)	910	1050	1500	1650	1790
L (mm)	545	580	580	730	865
P (mm)	1550	1750	1950	2250	2650
ØD (mm)	315	355	355	450	450
E (mm)	245	280	393	430	465
F (mm)	245	280	393	430	465
Weight (kg)	92	156	217	268	296

ECOEVO 2 PLUS H

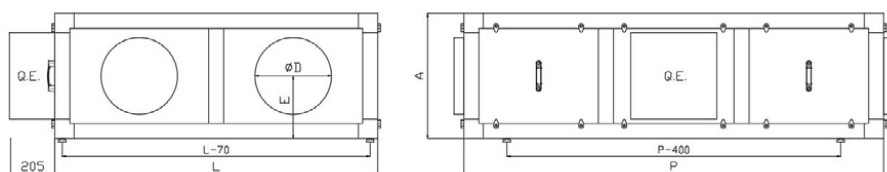

ECOEVO 2 PLUS V

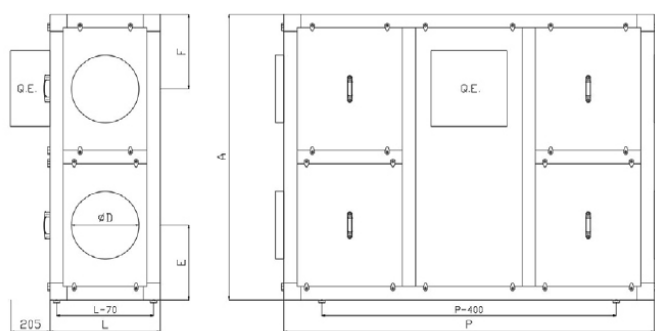

NOTE: MAINTENANCE AND ACCESS DISTANCE FOR THE MODULE UP TO SIZE 18 | 750 MM; FROM SIZE 18 | 1000 MM

DIMENSIONS
CHANGE OVER / DIRECT EXPANSION MODULE

MBCR/A	11	18	25	42	56
A (mm)	545	580	580	730	865
L (mm)	600	700	850	950	1100
P (mm)	700	800	850	900	1000
∅ Steam (mm)	16	16	28	35	35
∅ Liquid (mm)	22	28	35	35	42
∅ Water (pol)	3/4"	1"	1 1/4"	1 1/2"	2"
Weight (kg)	58	71	85	105	137

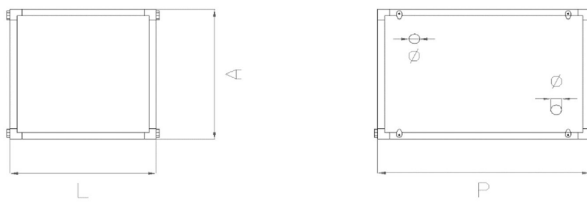

NOTE: MAINTENANCE AND ACCESS DISTANCE FOR THE MODULE UP TO SIZE 18 | 750 MM; FROM SIZE 18 | 1000 MM

WATER HEATING MODULE

MBAA	11	18	25	42	56
A (mm)	545	580	580	730	865
L (mm)	455	520	750	825	895
P (mm)	400	400	400	400	400
∅ Water (pol)	3/4"	1"	1 1/4"	1 1/2"	2"
Weight (kg)	33	38	45	51	59



DIMENSIONS

ELECTRIC HEATING MODULE

MBRE	11	18	25	42	56
A (mm)	545	580	580	730	865
L (mm)	455	525	750	825	895
P (mm)	400	400	400	400	400
Weight (kg)	32	38	45	51	59

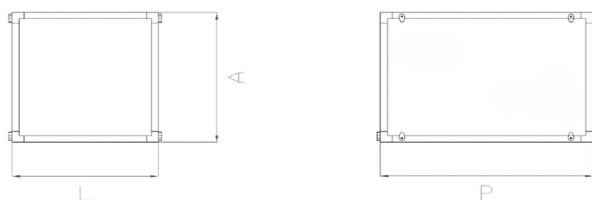

NOTE: MAINTENANCE AND ACCESS DISTANCE FOR THE MODULE UP TO SIZE 18 | 750 MM; FROM SIZE 18 | 1000 MM

ACOUSTIC ATTENUATION MODULE

MAA	11	18	25	42	56
A (mm)	545	580	580	730	865
L (mm)	475	570	650	750	750
P (mm)	750	750	750	750	750
Weight (kg)	47	53	55	66	74

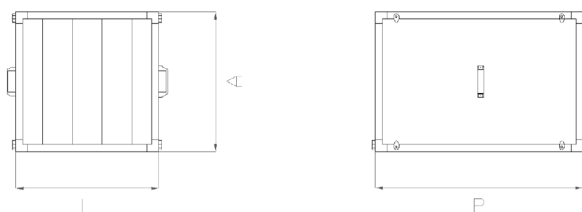

NOTE: MAINTENANCE AND ACCESS DISTANCE FOR THE MODULE UP TO SIZE 18 | 750 MM; FROM SIZE 18 | 1000 MM

STANDARD CONFIGURATIONS HORIZONTAL MODEL

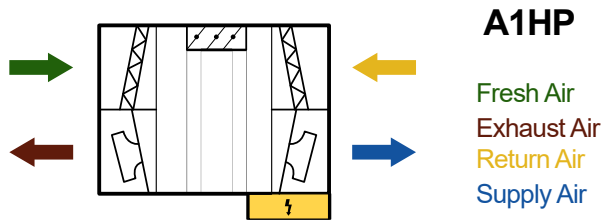

CONFIGURATIONS HORIZONTAL MODEL

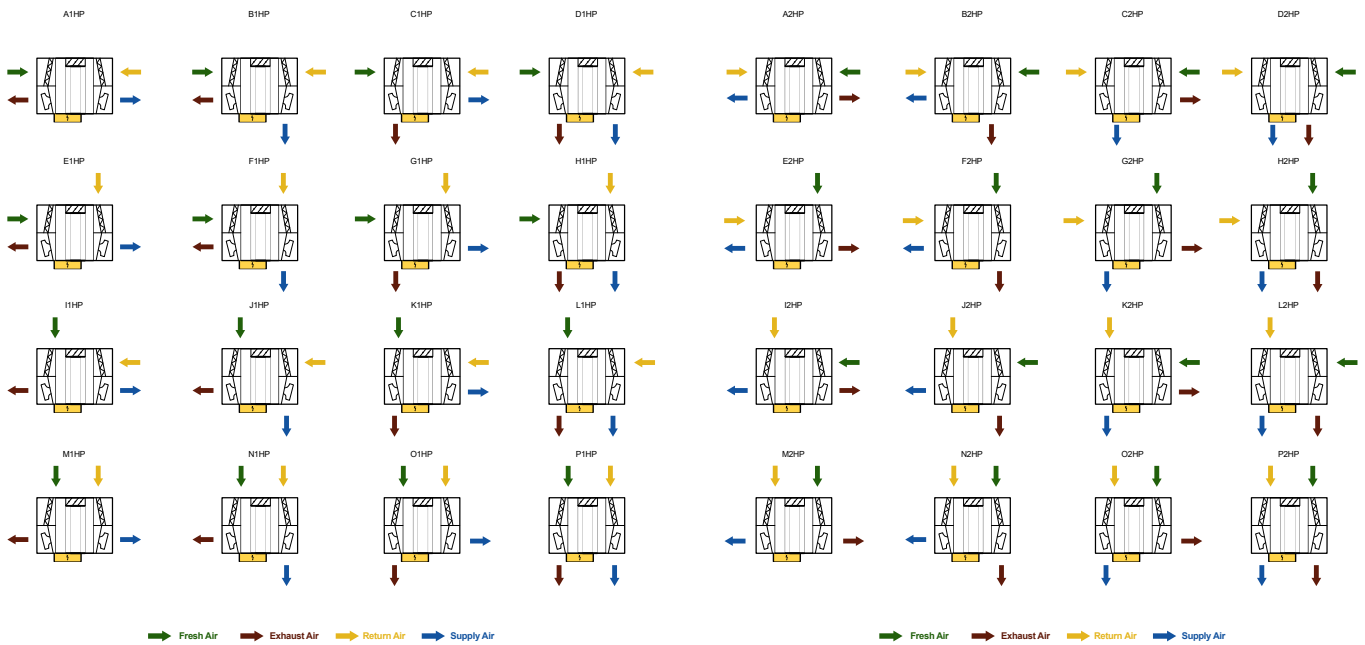



CONFIGURATIONS VERTICAL MODEL

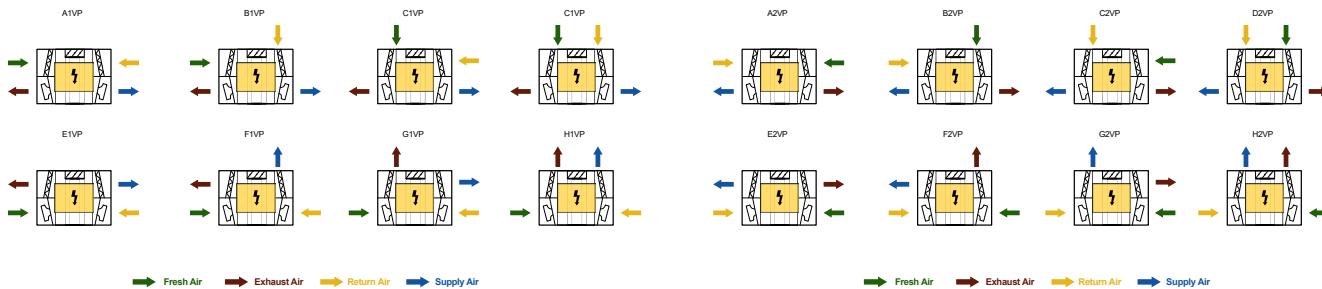

HEAT RECOVERY

ERP VERIFICATION DOCUMENT

MANUFACTURER		ARFIT AIR CONDITIONING, S.A.				
Model		11	18	25	42	56
Type		UVNR UVB				
Transmission Type		Variable Speed	Variable Speed	Variable Speed	Variable Speed	Variable Speed
Heat Recovery System Type		OTHER				
Heat Recovery Thermal Efficiency	%	78,3	78,1	79	79,6	81,1
Nominal Airflow	m ³ /s	0,268	0,521	0,65	1,114	1,483
Input Power	kW	0,189	0,489	0,522	1,199	1,467
SPFint	W/m ³ /s	785,7	1251,2	1023,7	1437,5	1597,8
Frontal Velocity	m/s	1,86	2,71	2,38	2,65	2,60
Nominal External Pressure	Pa	100	100	100	100	100
Reduction in Internal Pressure (Ventilation)	Pa	214	444	323	399	363
Static Efficiency of Fans	%	49,6	64,5	58,5	51,6	41,9
Maximum Declared Internal/External Leakage Rate	%	3,4/4,3	3,4/4,1	3,8/3,9	4,2/3,8	4,2/3,8
Filter Classification		F7/M5				
Description: Visual notice regarding filters		The filters warning is displayed on the unit's control system, either via a warning light or on-screen message, depending on the control system used. It is of the utmost importance to replace the filters regularly to improve the unit's performance and energy efficiency.				
Sound Power Level (Lwa)	dB(A)	52	66	60	64	65
Website		www.arfit.pt				



DEHUMIDIFICATION





DDS - DCS

INDEX



Plug & Play



Equipment with control



Display

DESCRIPTION

Domestic dehumidifier, DDS - DCS model, supplied as standard with advanced control, fully autonomous and designed for wall installation. DDS models are intended for direct installation within the conditioned space. Their design provides elegance, making them suitable for environments such as museums, archives, libraries, churches and basements. The sober yet refined appearance facilitates installation in both public and private environments, typically characterized by sophisticated design.

DCS models are designed for installation in a technical room adjacent to the dehumidified space: in this case, installation requires supply and return ductwork and plenums.

Polyester-coated structure for corrosion resistance and heat exchangers with anti-corrosion treatment. Removable front panel for full access to the unit, ensuring simple and fast maintenance. Screws and fastening systems in non-oxidizing materials, stainless steel or carbon steel with surface treatment. Stainless steel condensate tray. Rotary refrigerant compressor.

Available in 11 sizes with the possibility of installation within the conditioned space.

ADVANTAGES

- Direct installation in the conditioned space.
- Advanced integrated control.
- Fully autonomous humidity management.
- DDS model with casing for direct installation in the environment.
- DCS model concealed in adjacent technical room, with only supply and return grilles visible.
- Possibility of integrating Be.On module with direct cloud connection and Be.Smart monitoring.

ACCESSORIES

- Support feet
- Epoxy coil coating
- Silent version

COMPONENTS

FAN

3-speed EC centrifugal fan, allowing airflow rates in the range of 350 to 2000 m³/h. Corrosion-resistant structure.

HOT WATER COIL

Composed of a hot water post-heating coil and a 3-way valve directly controlled by the unit, designed to heat the supply air using hot water from a boiler or heat pump. The unit is supplied with coil and valve already installed and wired. For positioning of hydraulic connections, refer to dimensional drawings.

ELECTRICAL HEATERS

Allows heating of supply air when hot water is not available. Safety is ensured by a thermostat that, in case of overheating, deactivates the heating elements and signals an alarm. The unit is supplied with electric heating elements already installed internally.



CHARACTERISTICS

DDS-DCS	40	50	60	70	90	100
Dehumidification Capacity (30°/80% R.H.) (L/day)	46	52	62	68	92	99
Dehumidification airflow (m³/h)	350	450	500	600	700	800
Available static pressure (Pa)	40	40	40	40	40	40
Hot Water Coil (30°/80°-70°) (kW)	3,7	4,5	4,5	6,1	6,8	7,5
Electrical Heaters Power (kW)	1,5	1,5	1,5	2	3,6	3,6
Power consumption (kW)	0,9	0,9	1	1	1,7	1,7
Power Supply (V F Hz)	230 1 50					
Sound Pressure (dB(A))*	43	45	46	47	48	49

DDS-DCS	160	190	210	230	300
Dehumidification Capacity (30°/80% R.H.) (L/day)	165	186	211	226	300
Dehumidification airflow (m³/h)	1000	1200	1500	1500	2000
Available static pressure (Pa)	40	40	40	40	40
Hot Water Coil (30°/80°-70°) (kW)	10,1	11,5	14,5	14,5	17,7
Electrical Heaters Power (kW)	4,0	4,0	7,2	7,2	7,2
Power consumption (kW)	2,6	2,7	3,6	3,9	5
Power Supply (V F Hz)	230/1/50	230/1/50	400/3/50	400/3/50	400/3/50
Sound Pressure (dB(A))*	51	53	54	55	57

* Sound pressure level at 1 m, measured in open field in accordance with ISO 3744

DIMENSIONS

DDS	40	50	60	70	90	100	160	190	210	230	300
A (mm)	782	782	782	782	782	782	852	852	852	852	852
L (mm)	845	845	845	1045	1045	1045	1345	1345	1545	1545	1545
P (mm)	282	282	282	282	282	282	333	333	333	333	333
Weight (kg)	46	46	46	55	55	55	88	88	100	100	102
DCS	40	50	60	70	90	100	160	190	210	230	300
A (mm)	745	745	745	745	745	745	815	815	815	815	815
L (mm)	800	800	800	1000	1000	1000	1300	1300	1500	1500	1500
P (mm)	257	257	257	257	257	257	306	306	306	306	306
Weight (kg)	46	46	46	55	55	55	88	88	100	100	102

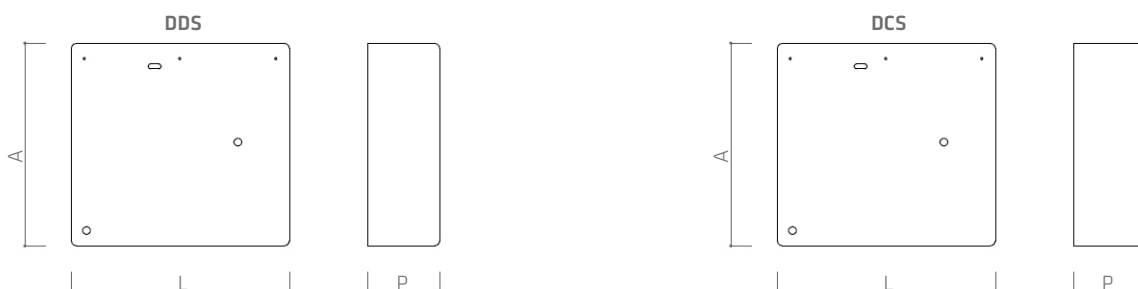



OPERATING LIMITS

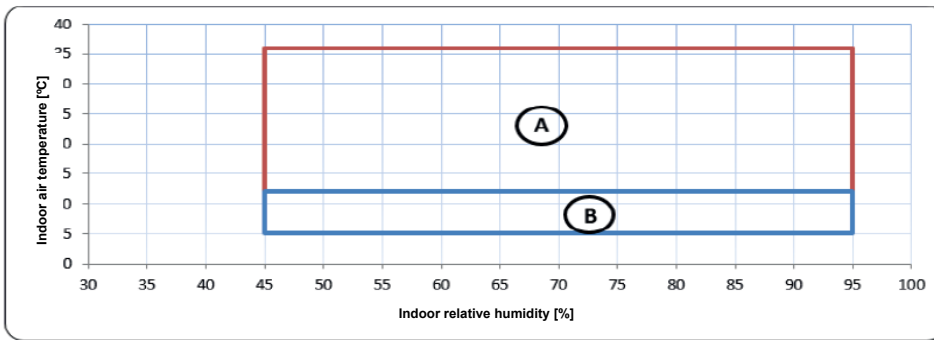

- A. Limite operacional do desumidificador
- B. Limite operacional com instalação de opção de GÁS DEFROST



Plug & Play

 Equipment
with control

Display

DESCRIPTION

Domestic dehumidifier, DVS model, supplied as standard with advanced control, fully autonomous and designed for wall installation, directly in the space to be dehumidified. The sober yet elegant appearance facilitates installation in public and private environments, typically characterized by sophisticated design.

Polyester-coated structure for corrosion resistance and heat exchangers with anti-corrosion treatment. Removable front panel providing full access to the unit for simple and fast maintenance. Screws and fastening systems in non-oxidizing materials, stainless steel or carbon steel with surface treatment. Stainless steel condensate tray.

Available in 7 sizes with the possibility of installation within the conditioned space or in an adjacent area.

ADVANTAGES

- Direct installation in the conditioned space.
- Advanced integrated control.
- Fully autonomous humidity management.
- Cabinet-type unit installed directly in the treated space.
- Possibility of integrating Be.On module with direct cloud connection and Be.Smart monitoring.

ACCESSORIES

- Support feet
- Epoxy coil coating
- Reinforced electrical heaters (optional)
- Silent version

COMPONENTS

FAN

Single-inlet electronic centrifugal fan with plastic impeller, providing higher corrosion resistance and significant noise reduction, improving acoustic comfort.

HOT WATER COIL

Composed of a hot water post-heating coil and a 3-way valve directly controlled by the unit, designed to heat the supply air using hot water from a boiler or heat pump. The unit is supplied with coil and valve already installed and wired. For positioning of hydraulic connections, refer to dimensional drawings.

ELECTRICAL HEATERS

Allows heating of supply air when hot water is not available. Safety is ensured by a thermostat that, in case of overheating, deactivates the heating elements and signals an alarm. The unit is supplied with electric heating elements already installed internally.





CHARACTERISTICS

DVS	50	70	90	100	160	190	210	230
Dehumidification Capacity (30°/80% R.H.) (L/day)	52	68	92	99	165	186	213	226
Dehumidification airflow (m³/h)	450	600	700	800	1000	1200	1400	1400
Available static pressure (Pa)	250	200	175	150	230	200	160	160
Hot Water Coil (30°/80°-70°) (kW)	5,2	6,1	6,8	7,5	10,4	11,9	13,3	13,3
Electrical heaters power (kW)	1,5	2	2	2	4	4	4	4
Power consumption (kW)	1,2	1	1,5	1,6	2,4	2,6	3,8	3,8
Power Supply (V F Hz)	230 1 50	230 1 50	230 1 50	230 1 50	230 1 50	230 1 50	400 3 50	400 3 50
Sound Pressure (dB(A))*	45	46	47	48	50	52	55	55

* Sound pressure level at 1 m, measured in open field in accordance with ISO 3744

DIMENSIONS

DVS	50	70	90	100	160	190	210	230
A (mm)	1652	1652	1652	1652	1652	1652	1652	1652
L (mm)	550	550	550	550	750	750	750	750
P (mm)	330	330	330	330	330	330	330	330
Weight (kg)	80	80	80	80	140	140	160	160

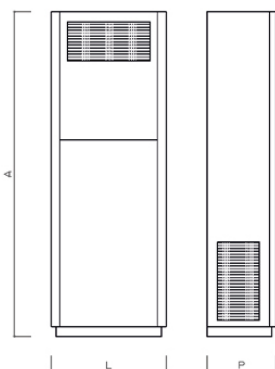

DEHUMIDIFICATION

OPERATING LIMITS

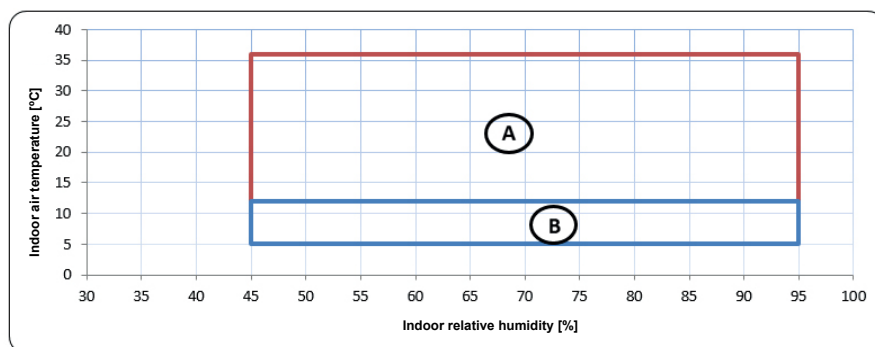

- A. Dehumidifier operating limit
- B. Operating limit with optional GAS DEFROST installation

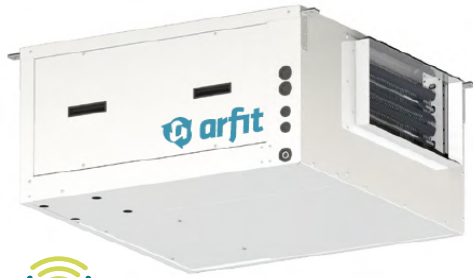

Plug & Play



Equipment with control



Display

ADVANTAGES

- Direct installation in the conditioned space.
- Advanced integrated control.
- Fully autonomous humidity management.
- Possibility of integrating Be.On module with direct cloud connection and Be.Smart monitoring.

DESCRIPTION

Domestic dehumidifier, DOS model, supplied as standard with advanced control, fully autonomous and designed for wall or false ceiling installation in humid environments, such as swimming pools, museums, libraries and archives. In these cases, installation requires ductwork, supply and return air grilles. It is fully autonomous in humidity management: the integrated control reads the ambient humidity and activates the dehumidification process when required.

Polyester-coated structure for corrosion resistance and heat exchangers with anti-corrosion treatment. Removable front panel for full access to the unit, ensuring simple and fast maintenance. Screws and fastening systems in non-oxidizing materials, stainless steel or carbon steel with surface treatment. Stainless steel condensate tray.

Available in 7 sizes with the possibility of installation within the conditioned space or in an adjacent area.

ACCESSORIES

- Epoxy coil coating
- Silent version
- Electrical heaters

COMPONENTS

FAN

Single-inlet electronic centrifugal fan with plastic impeller, providing higher corrosion resistance and significant noise reduction, improving acoustic comfort.

HOT WATER COIL

Composed of a hot water post-heating coil and a 3-way valve directly controlled by the unit, designed to heat the supply air using hot water from a boiler or heat pump. The unit is supplied with coil and valve already installed and wired.

For positioning of hydraulic connections, refer to dimensional drawings.

ELECTRICAL HEATERS

Allows heating of supply air when hot water is not available. Safety is ensured by a thermostat that, in case of overheating, deactivates the heating elements and signals an alarm. The unit is supplied with electric heating elements already installed internally.





CHARACTERISTICS

DOS	50	70	90	100	160	190	210	230
Dehumidification Capacity (30°/80% R.H.) (L/day)	52	68	92	99	165	186	213	226
Dehumidification airflow (m³/h)	450	600	700	800	1000	1200	1500	1500
Available static pressure (Pa)	250	200	175	150	230	200	150	150
Hot Water Coil (30°/80°-70°) (kW)	5,2	6,1	6,8	7,5	10,4	11,9	13,3	13,3
Electrical heaters power (kW)	1,5	2	2	2	4	4	4	4
Power consumption (kW)	1,2	1	1,5	1,6	2,4	2,6	3,8	3,8
Power Supply (V F Hz)	230 1 50	230 1 50	230 1 50	230 1 50	230 1 50	230 1 50	400 3+N 50	400 3+N 50
Sound Pressure (dB(A))*	45	46	47	48	50	52	53	54

*Sound pressure level at 1 m, measured in open field according to ISO 3744.

DIMENSIONS

DOS	50	70	90	100	160	190	210	230
A (mm)	1105	1105	1105	1105	1105	1105	1105	1105
B (mm)	801	801	801	801	1051	1051	1051	1051
C (mm)	410	410	410	410	510	510	510	510
D (mm)	500	500	500	500	500	500	500	500
E (mm)	500	500	500	500	500	500	500	500
F (mm)	500	500	500	500	500	500	500	500
Weight (kg)	84	84	84	84	147	147	168	168

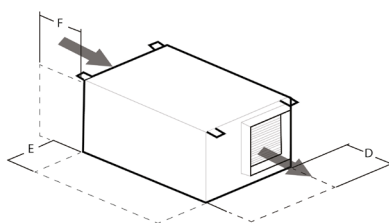
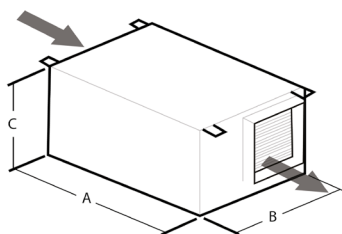

OPERATING LIMITS

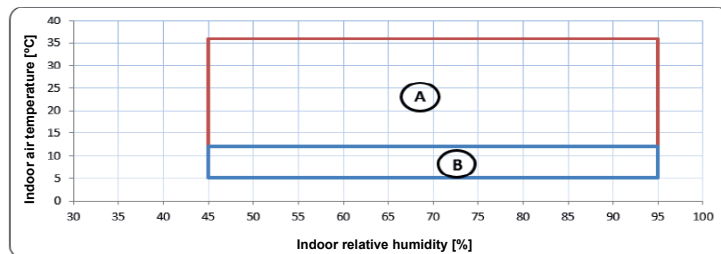

- A. Dehumidifier operating limit
- B. Operating limit with optional GAS DEFROST installation

CCV - CCA - CCW

INDEX



Plug & Play



Equipment with control



Display

DESCRIPTION

Domestic dehumidifier, CCV - CCA - CCW model, for high-precision humidity and temperature control, professional range with cabinet, designed for vertical floor-mounted installation. Equipped with integrated refrigeration circuit, with optional humidifier and electric heater. Complete control system fully integrated in the Plug & Play unit.

CCV models are designed for air-cooled condensation.

CCA models are equipped with remote condenser.

CCW models are designed for water-cooled condensation using the existing chiller system.

Available in 3 sizes, with installation within the conditioned space or in an adjacent area.

ADVANTAGES

- Long-term reliability.
- Low energy consumption.
- Advanced programmable control with time scheduling.
- Autonomous precision units for temperature and humidity control.
- Possibility of integrating Be.On module with direct cloud connection and Be.Smart monitoring.

ACCESSORIES

- Electrode humidifier
- Electrical heaters
- Filter
- Silent version

COMPONENTS

FAN

Centrifugal fan with backward-curved blades, directly coupled to an EC electric motor, ensuring lower energy consumption and reduced noise emission.

ELECTRICAL HEATERS

Allows heating of supply air when hot water is not available. Safety is ensured by a thermostat that, in case of overheating, deactivates the heating elements and signals an alarm. The unit is supplied with electric heating elements already installed internally.

INTERNAL COMPRESSOR

Internal compressor capable of three types of condensation: to an external condenser connected via copper piping with refrigerant gas (CCA model), water-cooled condensation using the existing chiller system (CCW model), or air-cooled condensation using a second EC fan to ventilate the compressor (CCV model).





CHARACTERISTICS

Model	CCV		CCA			CCW		
	300	450	300	450	900	300	450	900
Size	300	450	300	450	900	300	450	900
Total Cooling Capacity (kW)	1,45	2,15	1,50	2,2	4,4	1,55	2,25	4,6
Airflow (m³/h)	300	450	300	450	900	300	450	900
Available static pressure (Pa)	150	150	220	220	220	-	220	220
Electrical Heater Nom. Capacity (kW)	1,3	1,3	1,3	1,3	2,6	1,3	1,3	2,6
Electrical consumption (A)	2,5 - 3,9 - 13,5	3,2 - 6,3 - 22,4	2,5 - 3,9 - 13,5	3,2 - 6,3 - 22,4	7,1 - 11,7 - 40,8	2,2 - 3,1 - 12,7	2,9 - 4,9 - 21,2	6,5 - 9,3 - 38,4
Consumption without options (kW)	0,6	0,8	0,6	0,8	1,5	0,6	0,8	1,5
Power Supply (V F Hz)	230 1+N 50Hz 230 1+N 50Hz 230 1+N 50Hz 230 1+N 50Hz 230 1+N 50Hz 230 1+N 50Hz 230 1+N 50Hz 230 1+N 50Hz							
Nominal Humidifier Capacity (kW)	1,575	1,575	1,575	1,575	1,80	1,575	1,575	1,80
Max. consumption Unit + Heater (kW)	2,2	2,4	2,2	2,4	4,8	2,2	2,3	4,5
Max. consumption Unit + Heater + Humidifier (kW)	4,5	4,7	4,5	4,7	7,1	4,3	4,5	6,7
Max. consumption Unit + Heater + Humidifier (A)	15-19,3-28,9	15,7-21,8-37,9	15-19,3-28,9	15,7-21,8-37,9	25,3-32,8-61,9	15-19,3-28,9	15,4-20,4-36,7	24,7-30,4-59,5

DIMENSIONS

STANDARD DIMENSIONS

Model	CCV		CCA			CCW		
	300	450	300	450	900	300	450	900
Size	300	450	300	450	900	300	450	900
A (mm)	1690	1690	1690	1690	1690	1690	1690	1690
L (mm)	650	650	650	650	650	650	650	650
P (mm)	450	450	450	450	450	450	450	450
Weight (kg)	85	90	85	90	95	85	90	95

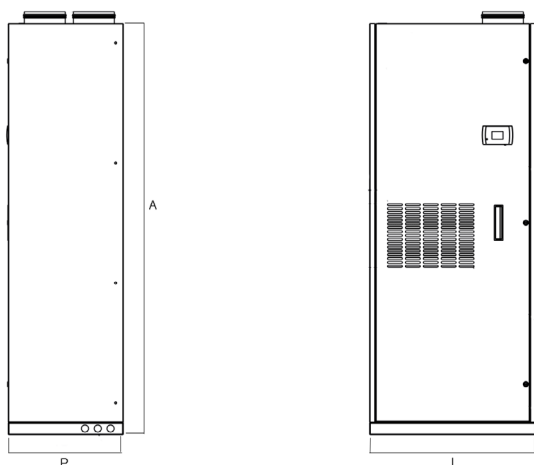

NOTE: MAINTENANCE DISTANCE: 700 MM

DIMENSIONS
DIMENSIONS WITH REAR INTAKE

Model	CCV			CCA			CCW		
Size	300	450	900	300	450	900	300	450	900
A (mm)	1690	1690	1690	1690	1690	1690	1690	1690	1690
L (mm)	650	650	650	650	650	650	650	650	650
P (mm)	450	450	450	450	450	450	450	450	450

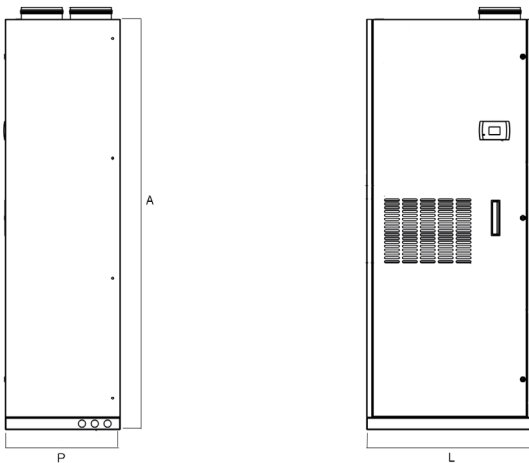

NOTE: MAINTENANCE DISTANCE: 400 MM

CONDENSER DIMENSIONS (ONLY AVAILABLE IN CCA)

Model	CCV	CCA	CCW
Size	300	450	900
A (mm)	300	300	300
L (mm)	463	463	463
P (mm)	286	286	286

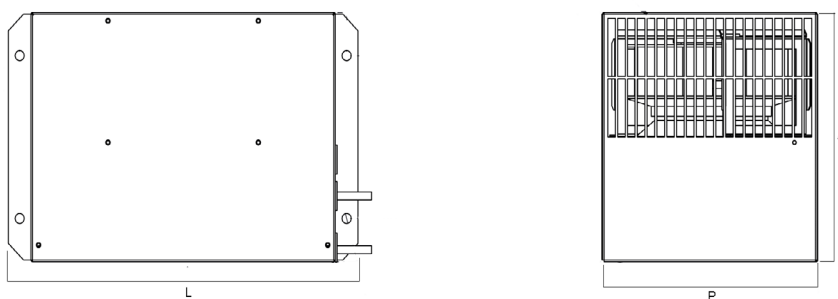

NOTE: MAINTENANCE DISTANCE: 500 MM



ID/SP - IT/ST

INDEX



Be.On



Plug & Play

Equipment
with control

Display

DESCRIPTION

Industrial dehumidifier, model ID/SP - IT/ST, designed for use in environments with high latent loads requiring 24-hour operation. ID-SP units are typically installed in environments such as public swimming pools, dairy processing plants, basements, wine cellars, warehouses, or wherever lack of humidity control may damage the structure or the stored product. Thanks to the temperature control function, IT-ST units equipped with a remote condenser ensure full control not only of humidity but also of ambient temperature, making them suitable for applications where control of both parameters is required.

Structure fully coated with polyester paint to resist corrosion. Heat exchangers treated with anticorrosion coatings. Fasteners and fixing systems made of non-oxidizing materials such as stainless steel or carbon steel with surface treatment. Units are equipped with removable panels to allow full access and facilitate maintenance.

Available in 20 sizes (ID-SP + IT-ST). Versions: ID (Industrial Dehumidifier), IT (Industrial Dehumidifier with condenser), SP (Pool Dehumidifier), and ST (Pool Dehumidifier with condenser).

ADVANTAGES

- Total humidity control (ID / SP) and ambient temperature and humidity control (IT / ST).
- Possible integration of Be On module with direct cloud connection and Be Smart monitoring.

ACCESSORIES

- Desuperheater
- Electrical Heaters
- EC fan
- Low-noise version

COMPONENTS

FAN

Centrifugal fan with backward-curved blades, directly coupled to an AC motor, uprated AC motor, or EC motor, the latter ensuring lower energy consumption and reduced noise levels.

HOT WATER COIL

Consisting of a hot water reheat coil and a 3-way valve directly controlled by the unit, intended to heat the supply air using hot water from a boiler or heat pump. The unit is supplied with the coil and valve already installed and wired. For hydraulic connection positioning, refer to dimensional drawings.

ELECTRICAL HEATERS

Allows heating of the supply air when no hot water is available. Safety is ensured by a thermostat which, in case of overheating, deactivates the heating elements and signals an alarm. The unit is supplied with the electric heating elements already installed inside.

INTERNAL COMPRESSOR

Internal compressor performing condensation in three possible ways: to a remote condenser connected by copper refrigerant pipes (model IT/ST), water condensation for pool reheating (optional desuperheater), or air condensation where air cools the compressor while reheating the air.

CHARACTERISTICS

ID-SP IT-ST	100	130	160	190	210	260	300
Dehumidification Capacity (30°/80% R.H.) (L/day)	100	128	157	190	210	268	302
Airflow (m³/h)	900	1200	1600	1600	2000	2800	2800
Cooling capacity (kW)	4,9	6,5	8	10	11	15	16
Available static pressure (Pa)	50	50	50	50	50	50	50
Available static pressure EC fan (kW)	450	450	400	400	550	350	350
Hot Water Coil (30°/80°-70°) (kW)	5,5	9,8	9,8	9,8	16,5	17	17
Desuperheater (kW)	1,7	2	2,5	2,8	3,5	4,6	4,8
Power consumption (kW)	2,2	2,5	3,6	5,3	5,5	6,8	7
Power Supply (V F Hz)	230 1 50	230 1 50	230 1 50	230 1 50	400 3 50	400 3 50	400 3 50
Sound pressure level (dB(A))*	56	56	60	61	62	62	63
Weight (Kg)	100	100	105	110	120	130	140

ID-SP IT-ST	350	450	580	770	950	1100	1400
Dehumidification Capacity (30°/80% R.H.) (L/day)	358	452	581	760	955	1120	1350
Airflow (m³/h)	3800	4000	4800	7000	8200	11000	12500
Cooling capacity (kW)	19	23	30	38	50	56	66
Available static pressure (Pa)	50	50	50	130	130	200	200
Available static pressure EC fan (kW)	550	540	450	450	400	480	450
Hot Water Coil (30°/80°-70°) (kW)	26,5	26,5	27	48	55	76	83
Desuperheater (kW)	4,8	5,8	8,1	11,5	14,5	14	18
Power consumption (kW)	8,5	10	13,4	16,3	20	23	26,6
Power Supply (V F Hz)	400 3 50	400 3 50	400 3 50	400 3 50	400 3 50	400 3 50	400 3 50
Sound pressure level (dB(A))*	64	65	65	66	66	68	69

ID-SP IT-ST	1500	1700	1900	2200	3000	4500
Dehumidification Capacity (30°/80% R.H.) (L/day)	1480	1710	1870	2180	2960	4650
Airflow (m³/h)	13000	15000	15000	17000	25000	35000
Cooling capacity (kW)	75	86	96	110	148	226
Available static pressure (Pa)	200	200	200	200	200	200
Available static pressure EC fan (kW)	450	480	480	450	400	280
Hot Water Coil (30°/80°-70°) (kW)	98	107	107	118	168	235
Desuperheater (kW)	19	22	25	29	37	55
Power consumption (kW)	29	35	38	42	62	90
Power Supply (V F Hz)	400 3 50	400 3 50	400 3 50	400 3 50	400 3 50	400 3+N 50
Sound pressure level (dB(A))*	70	71	71	72	73	74

*Sound pressure level at 1 m, measured in open field in accordance with ISO 3744.



DIMENSIONS

ID-SP IT-ST	100	130	160	190	210	260	300	350	450	580	750	950
A (mm)	900	900	900	900	900	900	900	1350	1350	1350	1350	1350
L (mm)	700	700	700	700	700	700	700	830	830	830	1000	1000
P (mm)	550	550	550	550	850	850	850	850	850	850	1400	1400
Weight (kg)	100	100	105	110	120	130	140	220	230	240	410	430

ID-SP IT-ST	1100	1400	1500	1700	1900	2200	3000	4500
A (mm)	1640	1640	1640	1640	1640	1640	1640	1640
L (mm)	1000	1000	1000	1000	1000	1000	1000	1000
P (mm)	1950	1950	2500	2500	2500	2500	3390	4430
Weight (kg)	650	720	780	840	900	950	1250	1550

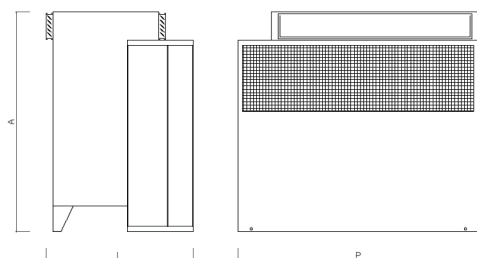

REMOTE CONDENSER	100	130	160	190	210	260	300	350	450	580	750	950
A (mm)	575	575	575	575	575	575	575	575	575	575	1130	1130
L (mm)	748	748	748	748	1303	1303	1303	1303	1858	1858	1858	1858
P (mm)	404	404	404	404	404	404	404	404	404	404	404	404
Weight (kg)	24	24	24	24	34	34	34	42	58	64	102	128

REMOTE CONDENSER	1100	1400	1500	1700	1900	2200	3000	4500
A (mm)	1130	1130	1144	1144	1144	1144	1144	1144
L (mm)	2413	2413	3800	3800	3800	3800	5550	3800
P (mm)	404	404	1100	1100	1100	1100	1100	1100
Weight (kg)	147	147	332	332	332	332	535	332

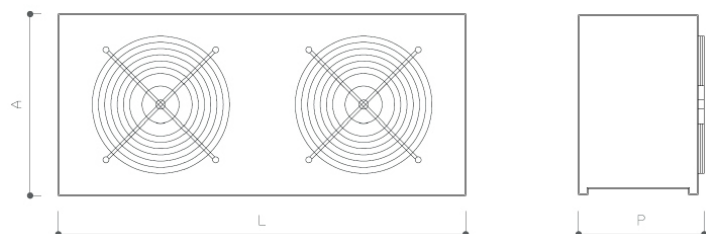

OPERATING LIMITS

ID-SP

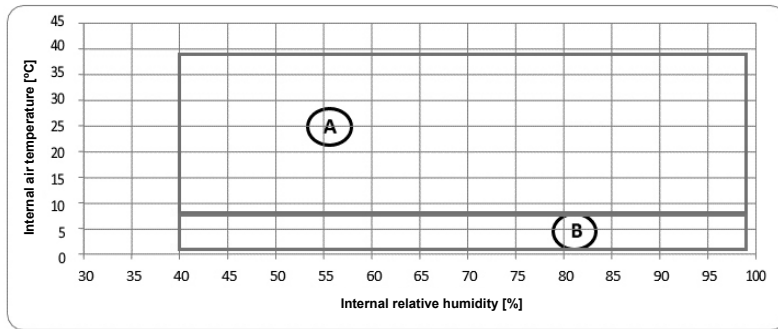

- A. Dehumidifier operating limit
- B. Operating limit with optional GAS DEFROST installation



SPR - STR

INDEX



Be.On



Plug & Play



Equipment with control



Display

DESCRIPTION

Heat recovery dehumidifier, models SPR - STR, ideal for swimming pools that not only require dehumidification but also need to renew indoor air while recovering its heat. Up to 80% efficiency guaranteed by the high-efficiency heat recovery system. These units use only high energy-efficiency EC fans and are equipped with software that allows measurement, control, and adjustment of the dehumidifier airflow. In STR units, thanks to the temperature control function with a remote condenser, the units ensure total control not only of humidity but also of ambient temperature, making them suitable for applications where both parameters must be controlled. Installation of the dehumidifier is extremely simple and fast.

Structure fully coated with polyester paint to resist corrosion. Heat exchangers treated with anticorrosion coatings. Fasteners and fixing systems made of non-oxidizing materials such as stainless steel or carbon steel with surface treatment. Removable panels allow full access to the unit and facilitate maintenance.

Available in 20 sizes (SPR + STR). Version with air-side heat recovery or recovery and condensation: SPR (Pool Dehumidifier) and STR (Pool Dehumidifier with condenser).

ADVANTAGES

- Equipped with software to measure, control, and adjust airflow.
- Total humidity control (SPR) and ambient temperature and humidity control (STR).
- High-efficiency heat recovery.
- Possible integration of Be.On module with direct cloud connection and Be.Smart monitoring.

ACCESSORIES

- Desuperheater
- Electrical Heaters
- Hot water coil
- Low-noise version
- Automatic airflow control

COMPONENTS

FAN

Centrifugal fan with backward-curved blades, directly coupled to an EC electric motor, ensuring lower energy consumption and reduced noise levels.

HOT WATER COIL

Consisting of a hot water reheat coil and a 3-way valve directly controlled by the unit, intended to heat the supply air using hot water from a boiler or heat pump. The unit is supplied with the coil and valve already installed and wired. For hydraulic connection positioning, refer to dimensional drawings.

ELECTRICAL HEATERS

Allows heating of the supply air when no hot water is available. Safety is ensured by a thermostat which, in case of overheating, deactivates the heating elements and signals an alarm. The unit is supplied with the electric heating elements already installed inside.

INTERNAL COMPRESSOR

Internal compressor performing condensation in three possible ways: to a remote condenser connected by copper refrigerant pipes (model STR), water condensation for pool reheating (optional desuperheater), or air condensation where air cools the compressor while reheating the air.

CHARACTERISTICS

SPR STR	100	130	160	190	210	260	300
Dehumidification Capacity (30°/80% R.H.) (L/day)	100	128	157	190	210	268	302
Nominal Airflow (m³/h)	900	1200	1600	1600	2000	2800	2800
Renewal Airflow (m³/h)	0-900	0-1200	0-1200	0-1200	0-2000	0-2000	0-2000
Cooling capacity (kW)	4,9	6,5	8	10	11	15	16
Supply/return pressure drop (Pa)	400/400	400/400	350/400	350/400	400/430	200/400	200/400
Heat recovery efficiency (%)	70	70	70	70	70	70	70
Hot Water Coil (kW)	5,5	9,8	9,8	9,8	16,5	17	17
Desuperheater (kW)	1,7	2	2,5	2,8	2,9	4,6	4,8
Power consumption (kW)	3,2	3,3	4,4	6,1	6,5	7,8	8
Power Supply (V/F/Hz)	230/1/50	230/1/50	230/1/50	230/1/50	400/3/50	400/3/50	400/3/50
Sound pressure level (dB(A))*	57	57	61	62	63	63	64
SPR STR	350	450	580	750	950	1100	1400
Dehumidification Capacity (30°/80% R.H.) (L/day)	358	452	581	760	955	1120	1350
Nominal Airflow (m³/h)	3800	4000	4800	7000	8200	11000	12500
Renewal Airflow (m³/h)	0-2000	0-2000	0-2000	0-6000	0-6000	0-11000	0-12500
Cooling capacity (kW)	19	23	30	38	50	56	66
Supply/return pressure drop (Pa)	460/500	440/480	440/420	650/480	600/450	750/1050	600/950
Heat recovery efficiency (%)	70	70	70	70	70	70	70
Hot Water Coil (kW)	26,5	26,5	27	48	55	76	83
Desuperheater (kW)	4,3	5,8	8,1	11,5	14,5	14	18
Power consumption (kW)	9,6	11,2	14,4	18,9	22,6	28,5	31,8
Power Supply (V/F/Hz)	400/3/50	400/3/50	400/3/50	400/3/50	400/3/50	400/3/50	400/3/50
Sound Pressure (dB(A))*	65	66	66	67	67	69	70
SPR STR	1500	1700	1900	2200	3000	4500	
Dehumidification Capacity (30°/80% R.H.) (L/day)	1480	1710	1870	2180	2960	4650	
Nominal Airflow (m³/h)	13000	15000	15000	17000	25000	35000	
Renewal Airflow (m³/h)	0-13000	0-13000	0-13000	0-13000	0-20000	0-28000	
Cooling capacity (kW)	75	86	96	110	148	226	
Supply/return pressure drop (Pa)	500/700	480/650	480/650	400/600	300/480	280/450	
Heat recovery efficiency (%)	70	70	70	70	70	70	
Hot Water Coil (kW)	98	107	107	118	168	235	
Desuperheater (kW)	19	22	25	29	38	55	
Power consumption (kW)	34,2	40,4	43,8	47,8	68	96	
Power Supply (V/F/Hz)	400/3/50	400/3/50	400/3/50	400/3/50	400/3/50	400/3/50	
Sound Pressure (dB(A))*	71	72	72	73	74	75	

*Sound pressure level at 1 m, measured in open field according to ISO 3744.



DIMENSIONS

SPR STR	100	130	160	190	210	260	300	350	450	580	750	950
A (mm)	1320	1320	1320	1320	1320	1320	1320	1769	1769	1769	1950	1950
L (mm)	550	550	550	550	850	850	850	850	850	850	1400	1400
P (mm)	1452	1452	1452	1452	1452	1452	1452	1682	1682	1682	2331	2331
Weight (kg)	155	155	160	165	200	210	220	250	270	300	515	540

SPR STR	1100	1400	1500	1700	1900	2200	3000	4500
A (mm)	2385	2385	2385	2385	2385	2385	2385	2385
L (mm)	1950	1950	2500	2500	2500	2500	3390	4430
P (mm)	2510	2510	2510	2510	2510	2510	2510	2510
Weight (kg)	870	1060	1280	1280	1290	1290	1680	2825

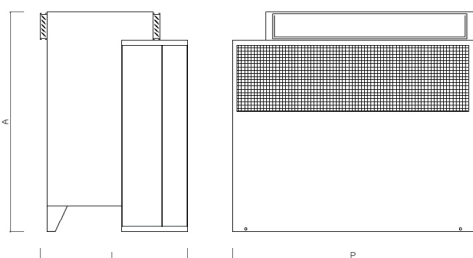

DEHUMIDIFICATION

REMOTE CONDENSER	100	130	160	190	210	260	300	350	450	580	750	950
A (mm)	575	575	575	575	575	575	575	575	575	575	1130	1130
L (mm)	748	748	748	748	1303	1303	1303	1303	1858	1858	1858	1858
P (mm)	404	404	404	404	404	404	404	404	404	404	404	404
Weight (Kg)	24	24	24	24	34	34	34	42	58	64	102	128

REMOTE CONDENSER	1100	1400	1500	1700	1900	2200	3000	4500*
A (mm)	1130	1130	1144	1144	1144	1144	1144	1144
L (mm)	2413	2413	3800	3800	3800	3800	5550	3800
P (mm)	404	404	900	900	900	900	900	900
Weight (Kg)	147	147	332	332	332	332	535	332

* Size 4500 requires two condensers; the indicated characteristics are per condenser.

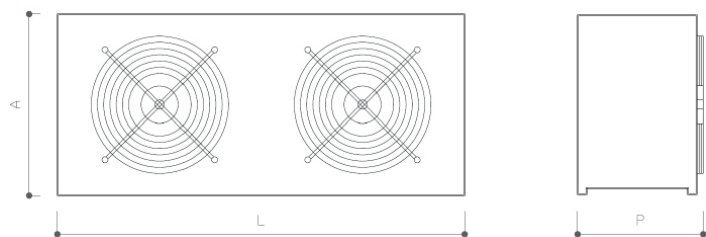

OPERATING LIMITS

SPR

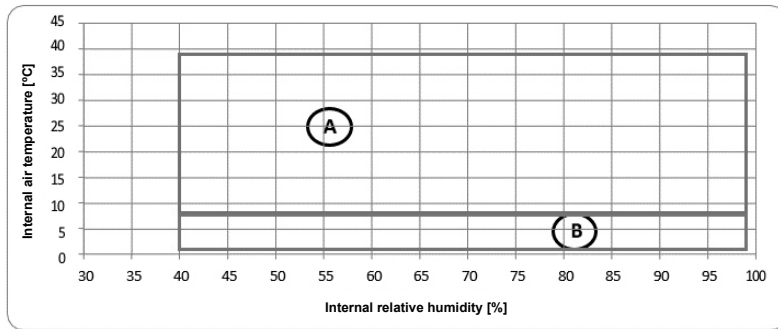

- A. Dehumidifier operating limit
- B. Operating limit with optional GAS DEFROST installation

STR

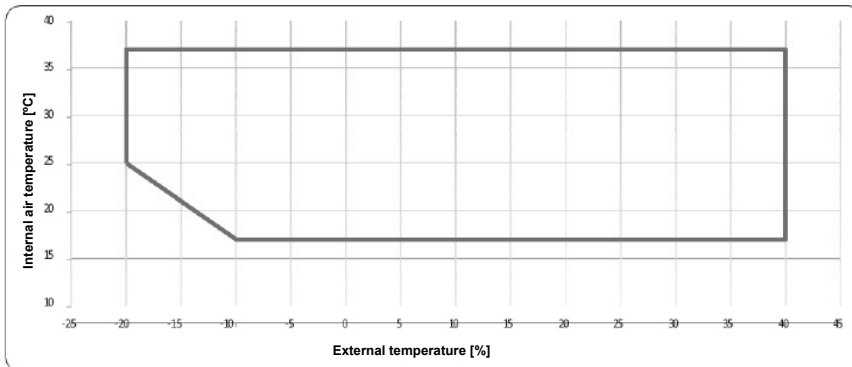

A decorative graphic consisting of multiple thin, light green lines that flow and wave across the page, creating a sense of movement and depth. The lines are most concentrated in the middle section where the text is located.

your
COMPLETE SOLUTIONS

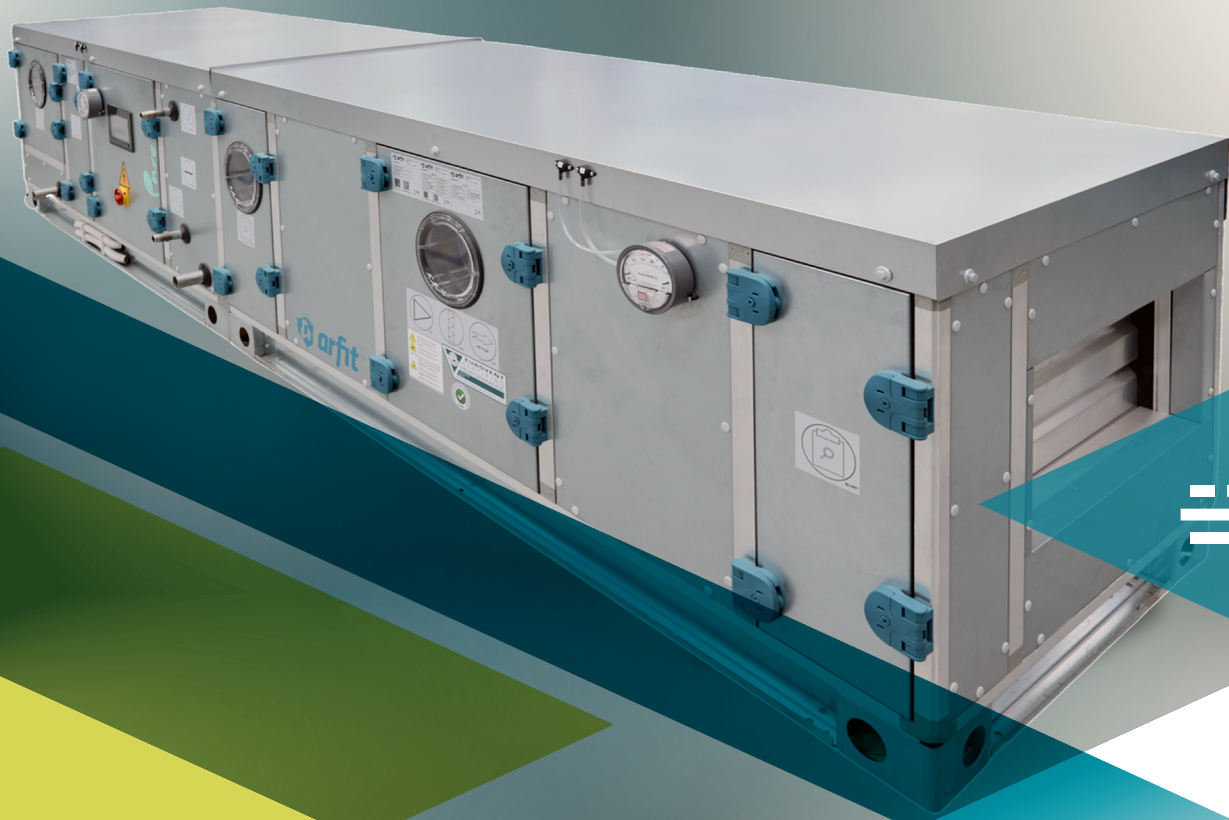

AIR TREATMENT



PURE P

INDEX



Plug & Play



Equipment with control



Display

DESCRIPTION

Air handling unit, model PURE P, designed to adapt to all requirements of HVAC and air treatment systems, combining demanding technical specifications with the highest performance standards.

Tested in independent laboratories in accordance with EN 1886 and EN 13053 standards, VDI 6022, and EUROVENT certified. High mechanical strength structure with double-skin panels and aluminum profiles with thermal break. Panels are 50 mm thick with rock wool insulation (70 kg/m³), ensuring high thermal performance in accordance with EN 1886. Unique versatility, with fully removable panels via quick-fit hinges, ensuring easy and fast access for installation and maintenance. The height, length, and depth of the unit can be adapted to the available technical space.

The electrical panel is integrated into the unit, providing a truly integrated solution.

STANDARDS AND CERTIFICATIONS



CLASSIFICATION ACCORDING TO EN 1886

Mechanical strength of casing	D1 (M)
Casing air leakage at -400 Pa	L1 (M)
Casing air leakage at +700 Pa	L1 (M)
Filter bypass leakage	F9 (M)
Thermal transmittance of casing	T2
Thermal bridging of casing	TB2

ADVANTAGES

- Unit adaptable to available space.
- Corrosion class C5.
- Flexibility and versatility.
- Plug & Play control system.
- Integrated electrical panel.
- Warranty up to 5 years.
- Possible integration of Be On module with direct cloud connection

ACCESSORIES

- ePM10 50% / M5 filter
- ePM1 50% / F7 filter
- ePM1 80% / F9 filter
- Differential air pressure switch
- Constant airflow control
- CO₂ Control

COMPONENTS

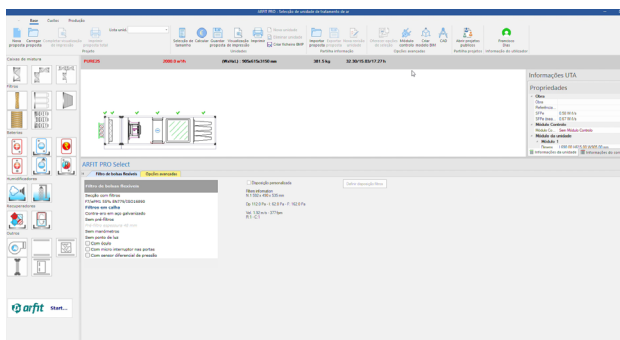

PURE H

INDEX



Be.On



Plug & Play



Equipment with control



Display

DESCRIPTION

Hygienic air handling unit, model PURE H, developed to meet the highest requirements of HVAC and air treatment systems in environments with stringent hygiene demands, ensuring high technical and sanitary performance standards. Units are tested in independent laboratories in accordance with EN 1886 and EN 13053 standards, as well as hygienic requirements defined by VDI 6022-1 and DIN 1946-4, holding EUROVENT certification and hygienic certification issued by TÜV NORD (PURE-H).

The structure features high mechanical strength, consisting of aluminum profiles with thermal break and double-skin panels 50 mm thick. These panels incorporate rock wool insulation with a density of 70 kg/m³, ensuring high thermal performance in accordance with EN 1886. The unit design also prioritizes hygiene and ease of cleaning, with suitable internal surfaces and selected materials to prevent dirt accumulation and facilitate maintenance operations.

The unit also stands out for its high construction versatility, allowing dimensional adaptation. Panels are fully removable via quick-fit hinges, ensuring simple and effective access to internal components for inspection, cleaning, and maintenance. With an integrated electrical panel, it provides a functional and fully integrated solution for system management and control.

STANDARDS AND CERTIFICATIONS

TÜV NORD

TÜV NORD Systems GmbH & Co. KG

Certified Product

Air Handling Unit Range: "PURE-H"

Certification Scheme TNS-KKL Hygiene Characteristics tested on sample acc. to DIN 1946-4 and VDI 6022-1

tuev-nord.com KKL/1010/21



CLASSIFICATION ACCORDING TO EN 1886

Mechanical strength of casing	D1 (M)
Casing air leakage at -400 Pa	L1 (M)
Casing air leakage at +700 Pa	L1 (M)
Filter bypass leakage	F9 (M)
Thermal transmittance of casing	T2
Thermal bridging of casing	TB3

ADVANTAGES

- Unit adaptable to available space.
- Corrosion class C5.
- Flexibility and versatility.
- Plug & Play control system.
- Integrated electrical panel.
- Warranty up to 5 years.
- Possible integration of Be On module with direct cloud connection and Be Smart monitoring.

ACCESSORIES

- ePM10 50% / M5 filter
- ePM1 50% / F7 filter
- ePM1 80% / F9 filter
- Differential air pressure switch
- Constant airflow control
- CO₂ control

COMPONENTS

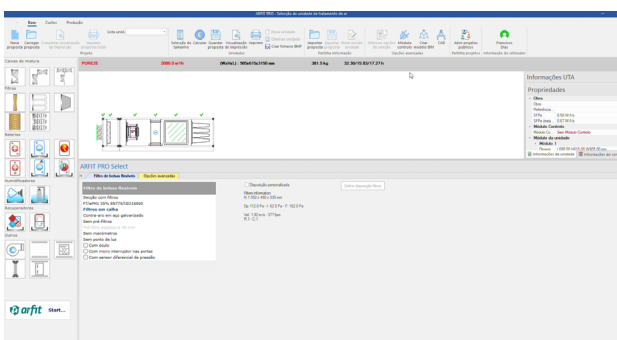

A decorative graphic consisting of numerous thin, light green lines that flow and wave across the middle of the page, creating a sense of movement and depth. The lines are more densely packed in some areas, creating a mesh-like effect.

your
COMPLETE SOLUTIONS



AIR HANDLING / CONTIONING UNITS



UBP EC

INDEX

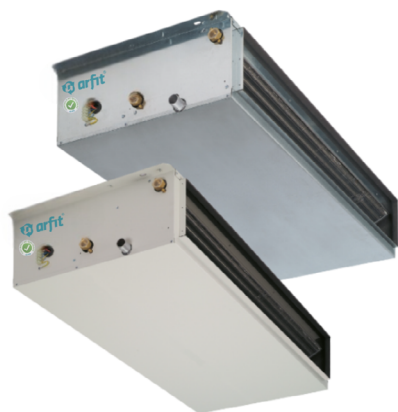

DESCRIPTION

Low profile unit, model UBP EC, with removable self-supporting panels provided with fixing holes for direct ceiling or wall mounting through the structure. Reversible unit access on-site for easy maintenance.

Single-skin structure made of galvanized steel sheet with thermal and acoustic insulation (Class M1) on all parts in contact with the coils.

Available in 9 sizes for 2-pipe systems and 12 sizes for 4-pipe systems, with rear or front air intake and horizontal or vertical installation.

ADVANTAGES

- High efficiency.
- Removable self-supporting panels.
- Compact dimensions.
- Easy maintenance.
- Acoustic attenuation.
- Optional double-skin panels with 25 mm insulation.
- Optional marine protection coating.
- Optional stainless steel panels.

ACCESSORIES

- G3 filter
- Plenum with G3 filter
- Plenum with G7 filter
- Bioxygen
- Standard control thermostat, with optional ModBus communication
- 3-way valve kit with On-Off or Modulating actuator
- 2-way valve kit with On-Off or Modulating actuator
- Auxiliary condensate drain tray for valves
- Unit in pre-painted steel sheet
- Unit with double-skin panel and 20 mm fiberglass insulation
- Electrical heaters
- Acoustic attenuators

COMPONENTS

MOTOR

High-efficiency EC electronically commutated motor with 2 protections (TP-thermal/Klixon + EP-electronic/SW), IP20, Class B, double insulation, inverter with dry alarm contact, 230 Vac -1Ph-50/60 Hz. High-efficiency HEE motor with improved performance and consequent CO₂ reduction. Modulating control with 0...10 Vdc signal. Airflow modulation from 0-100% allows performance adjustment at any moment according to actual room requirements, ensuring total comfort and reduced noise levels.

FAN

Ventilation section composed of 1, 2, or 3 double-inlet centrifugal fans with latest-generation ABS blades, directly coupled to the electric motor. Manufactured in accordance with international standards. Mounted on anti-vibration supports and statically and dynamically balanced. Large-diameter fans (high airflow and high static pressure) with low RPM speed (low noise level). Easy removal and available in different motor configurations.

WATER COIL

High-efficiency heat exchanger composed of copper tubes and aluminum fins mechanically expanded onto the tubes. Coil connections are supplied with anti-torsion system, manual air vent, and water drain valves. Standard hydraulic connections on the right side, with left-side hydraulic connections available on request. Unit hydraulic connections can be easily reversed on-site. Unit suitable for installation in 2-pipe or 4-pipe systems. Coils tested at 30 bar pressure, suitable for operation with water at a maximum pressure of 15 bar.

CHARACTERISTICS

UBP EC 2 PIPES	122			132			142		
	min.	med.	max.	min.	med.	max.	min.	med.	max.
Speed									
Airflow (m ³ /h)	318	755	1198	350	835	1325	340	810	1283
Water flow rate (2) (l/h)	1089			1378			1610		
Water flow rate (3) (l/h)	1208			1489			1586		
Motor Power (kW)	0,2			0,2			0,2		
Power Supply (V F Hz)	230 1 50			230 1 50			230 1 50		
IMAX (A)	1,4			1,4			3,4		
Sound Pressure (4) (dB(A))	16	37	51	17	39	51	17	39	51
Static Pressure (Pa)	100			100			100		
Water pressure drop (2) (kPa)	30,8			33,8			33,1		
Water pressure drop (3) (kPa)	32,9			34,7			27,9		
Total cooling capacity (1) (kW)	3,15	5,02	6,33	3,97	6,34	8,01	4,65	7,42	9,36
Sensible cooling capacity (1) (kW)	2,02	3,60	4,86	2,49	4,45	6,02	2,80	5,01	6,76
Heating capacity (3) (kW)	3,11	5,32	7,02	3,85	6,60	8,71	4,08	7	9,22
Main coil	3R			3R			4R		

CHARACTERISTICS

UBP EC 2 PIPES	222			232			242		
Speed	min.	med.	max.	min.	med.	max.	min.	med.	max.
Airflow (m³/h)	527	1393	2253	575	1517	2455	547	1442	2333
Water flow rate (2) (l/h)	1824			2309			2705		
Water flow rate (3) (l/h)	2145			2653			2804		
Motor Power (kW)	0,4			0,4			0,4		
Power Supply (V F Hz)	230 1 50			230 1 50			230 1 50		
IMAX (A)	1,80			1,80			1,80		
Sound Pressure (4) (dB(A))	18	41	52	19	42	53	19	42	53
Static Pressure (Pa)	100			100			100		
Water pressure drop (2) (kPa)	21,9			29,9			23,9		
Water pressure drop (3) (kPa)	26,2			34,3			22,3		
Total cooling capacity (1) (kW)	4,91	8,32	10,61	6,23	10,52	13,42	7,29	12,33	15,72
Sensible cooling capacity (1) (kW)	3,22	6,20	8,48	3,99	7,65	10,48	4,46	8,54	11,70
Heating capacity (3) (kW)	5,09	9,33	12,45	6,32	11,54	15,42	6,68	12,20	16,30
Main coil	3R			3R			3R		
UBP EC 2 PIPES	322			332			342		
Speed	min.	med.	max.	min.	med.	max.	min.	med.	max.
Airflow (m³/h)	790	2138	3485	858	2320	3783	818	2215	3610
Water flow rate (2) (l/h)	2617			3320			3993		
Water flow rate (3) (l/h)	3162			3916			4180		
Motor Power (kW)	0,6			0,6			0,6		
Power Supply (V F Hz)	230 1 50			230 1 50			230 1 50		
IMAX (A)	2,50			2,50			2,50		
Sound Pressure (4) (dB(A))	15	41	54	16	43	55	16	43	55
Static Pressure (Pa)	100			100			100		
Water pressure drop (2) (kPa)	17,5			24,7			20,8		
Water pressure drop (3) (kPa)	22,2			29,8			19,8		
Total cooling capacity (1) (kW)	6,93	11,88	15,22	8,79	15,08	19,30	10,57	18,13	23,22
Sensible cooling capacity (1) (kW)	4,65	9,07	12,48	5,75	11,22	15,44	6,48	12,65	17,41
Heating capacity (3) (kW)	7,38	13,70	18,39	9,13	16,96	22,77	9,74	18,11	24,30
Main coil	3R			3R			4R		

CHARACTERISTICS

UBP EC 4 PIPES	124			134			224			234		
Speed	min.	med.	max.	min.	med.	max.	min.	med.	max.	min.	med.	max.
Airflow (m ³ /h)	305	728	1155	335	805	1275	512	1342	2175	547	1442	2333
Water flow rate (2) (l/h)	1066			1345			1780			2234		
Water flow rate (3) (l/h)	335			357			579			607		
Motor Power (kW)	0,2			0,2			0,2			0,2		
Power Supply (V F Hz)	230 1 50			230 1 50			230 1 50			230 1 50		
IMAX (A)	1,40						1,80					
Sound Pressure (4) (dB(A))	16	37	51	17	39	51	18	41	52	19	42	53
Static Pressure (Pa)	100			100			100			100		
Water pressure drop (2) (kPa)	29,5			32,2			20,9			28,0		
Water pressure drop (3) (kPa)	11,1			12,4			8,8			9,4		
Total cooling capacity (1) (kW)	3,07	4,91	6,20	3,87	6,20	7,82	4,81	8,11	10,35	6,02	10,18	12,99
Sensible cooling capacity (1) (kW)	1,96	3,51	4,74	2,41	4,33	5,85	3,16	6,03	8,27	3,83	7,34	10,05
Heating capacity (3) (kW)	3,60	6,02	7,80	3,82	6,42	8,31	5,79	10,27	13,46	6,05	10,78	14,12
Main coil	3R			3R			3R			3R		
UBP EC 4 PIPES	324			334			125			135		
Speed	min.	med.	max.	min.	med.	max.	min.	med.	max.	min.	med.	max.
Airflow (m ³ /h)	760	2060	3355	818	2215	3610	298	713	1130	328	783	1240
Water flow rate (2) (l/h)	2569			3226			1051			1321		
Water flow rate (3) (l/h)	848			886			535			569		
Motor Power (kW)	0,6			0,6			0,2			0,2		
Power Supply (V F Hz)	230 1 50			230 1 50			230 1 50			230 1 50		
IMAX (A)	2,50						1,40					
Sound Pressure (4) (dB(A))	15	41	54	16	43	55	16	37	51	17	39	51
Static Pressure (Pa)	100			100			100			100		
Water pressure drop (2) (kPa)	16,9			23,3			28,7			31,1		
Water pressure drop (3) (kPa)	8,9			9,6			9,1			10,1		
Total cooling capacity (1) (kW)	6,80	11,67	14,94	8,54	14,65	18,76	3,03	4,84	6,11	3,81	6,09	7,68
Sensible cooling capacity (1) (kW)	4,54	8,88	12,21	5,54	10,83	14,90	1,92	3,45	4,66	2,37	4,24	5,73
Heating capacity (3) (kW)	8,28	15	19,72	8,66	15,67	20,62	5,73	9,61	12,45	6,10	10,22	13,23
Main coil	3R			3R			3R			3R		

CHARACTERISTICS

UBP EC 4 PIPES	225			235			325			335		
Speed	min.	med.	max.	min.	med.	max.	min.	med.	max.	min.	med.	max.
Airflow (m ³ /h)	493	1302	2110	537	1418	2295	743	2008	3273	800	2163	3528
Water flow rate (2) (l/h)	1750			2220			2524			3181		
Water flow rate (3) (l/h)	936			989			1381			1454		
Motor Power (kW)	0,4			0,4			0,6			0,6		
Power Supply (V F Hz)	230 1 50			230 1 50			230 1 50			230 1 50		
IMAX (A)	1,80						2,50					
Sound Pressure (4) (dB(A))	18	41	52	19	42	53	15	41	54	16	43	55
Static Pressure (Pa)	100			100			100			100		
Water pressure drop (2) (kPa)	20,2			27,6			16,2			22,6		
Water pressure drop (3) (kPa)	7,5			8,2			7,3			8,0		
Total cooling capacity (1) (kW)	4,72	7,97	10,18	5,98	10,12	12,91	6,69	11,46	14,68	8,42	14,44	18,49
Sensible cooling capacity (1) (kW)	3,08	5,91	8,10	3,79	7,28	9,97	4,45	8,69	11,95	5,49	10,70	14,73
Heating capacity (3) (kW)	9,32	16,59	21,76	9,85	17,56	23	13,50	24,42	32,12	14,21	25,69	33,81
Main coil	3R			3R			3R			3R		

(1) Water temperature 7°C/12°C, dry bulb temperature 27°C, wet bulb temperature 19°C (47% relative humidity) according to EN 1397:2015

(2) Water temperature 7°C/12°C, dry bulb temperature 27°C, wet bulb temperature 19°C (47% relative humidity)

(3) Water temperature 45°C/40°C for 2-pipe units and water temperature 80°C/60°C for 4-pipe units, air temperature 20°C

(4) Sound pressure level measured at 3 m in free field conditions, according to ISO 3741 - ISO 3742

DIMENSIONS UBP 2 PIPES

UBP EC H	122	132	142	222	232	242	322	332	342
L (mm)	800	800	800	1200	1200	1200	1600	1600	1600
A (mm)	760	760	760	1160	1160	1160	1560	1560	1560
B (mm)	235	235	235	235	235	235	235	235	235
Weight (kg)	38	39	41	53	55	58	69	71	74
UBP EC V	122	132	142	222	232	242	322	332	342
L (mm)	800	800	800	1200	1200	1200	1600	1600	1600
A (mm)	760	760	760	1160	1160	1160	1560	1560	1560
B (mm)	235	235	235	235	235	235	235	235	235
Weight (kg)	38	39	41	53	55	58	69	71	74

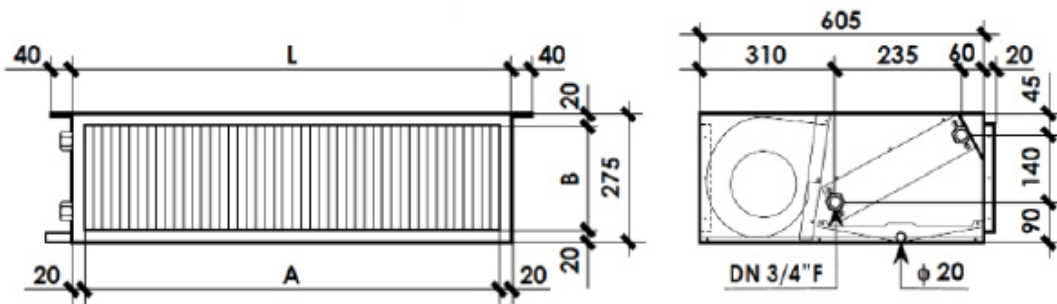

DIMENSIONS UBP 4 PIPES

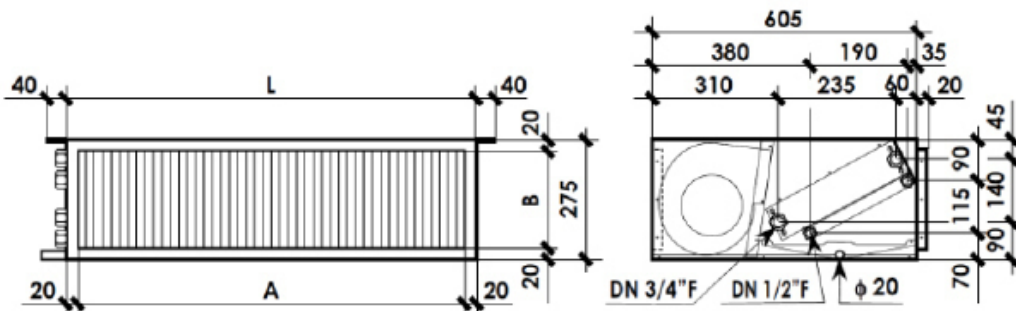
UBP EC H	124	134	224	234	324	334	125	135	225	235	325	335
L (mm)	800	800	1200	1200	1600	1600	800	800	1200	1200	1600	1600
A (mm)	760	760	1160	1160	1560	1560	760	760	1160	1160	1560	1560
B (mm)	235	235	235	235	235	235	235	235	235	235	235	235
Weight (kg)	40	41	56	58	73	75	40	41	56	58	73	75
UBP EC V	124	134	224	234	324	334	125	135	225	235	325	335
L (mm)	800	800	1200	1200	1600	1600	800	800	1200	1200	1600	1600
A (mm)	760	760	1160	1160	1560	1560	760	760	1160	1160	1560	1560
B (mm)	235	235	235	235	235	235	235	235	235	235	235	235
Weight (kg)	40	41	56	58	73	75	40	41	56	58	73	75

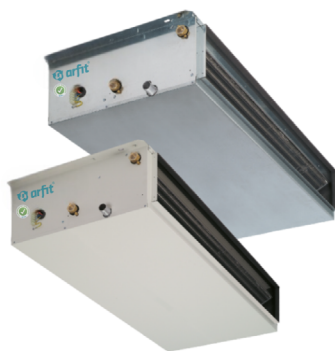

UBP AC

INDEX



Thermal and acoustic insulation



Bioxygen

DESCRIPTION

Low profile unit, model UBP, with removable self-supporting panels, provided with fixing holes for direct ceiling or wall mounting through the structure, and reversible unit access on-site for easy maintenance.

Structure type available with galvanized steel panel and internal thermal-acoustic insulation (Class M1) on all parts in contact with the coils.

Available in 9 sizes for 2-pipe systems and 12 sizes for 4-pipe systems, with rear or front air intake and horizontal or vertical installation.

ADVANTAGES

- High efficiency.
- Removable self-supporting panels.
- Compact dimensions.
- Easy maintenance.
- Acoustic attenuation.
- Optional double-skin panels with 25 mm insulation.
- Optional marine protection coating.
- Optional stainless steel panels.

ACCESSORIES

- G3 filter
- Plenum with G3 filter
- Plenum with G7 filter
- Bioxygen
- Standard control thermostat, with optional ModBus communication
- 3-way valve kit with On-Off or Modulating actuator
- 2-way valve kit with On-Off or Modulating actuator
- Auxiliary condensate drain tray for valves
- Unit in pre-painted steel sheet
- Unit with double-skin panel and 20 mm fiberglass insulation
- Electrical heaters
- Acoustic attenuators

COMPONENTS

MOTOR

Single-phase asynchronous AC motor with 5 speeds (3 factory wired), equipped with TH thermal protection (Klixon), permanently connected run capacitor, 4 poles, IP20, Class F, double insulation, 230 Vac - 1Ph - 50/60 Hz.

FAN

Ventilation section composed of 1, 2, or 3 double-inlet centrifugal fans with latest-generation ABS blades, directly coupled to the motor. Manufactured in accordance with international standards. Mounted on anti-vibration supports, statically and dynamically balanced. Large-diameter fans (high airflow and high static pressure) with low RPM speed (low noise level), easy to remove, and available in different motor configurations.

WATER COIL

High-efficiency heat exchanger composed of copper tubes and aluminum fins mechanically expanded onto the tubes. Coil connections are supplied with anti-torsion system, manual air vent, and water drain valves. Standard hydraulic connections on the right side, with left-side hydraulic connections available on request. Unit hydraulic connections can be easily reversed on-site. Unit suitable for installation in 2-pipe or 4-pipe systems. Coils tested at 30 bar pressure, suitable for operation with water at a maximum pressure of 15 bar.

CHARACTERISTICS

UBP AC 2 PIPES	122			132			142		
	min.	med.	max.	min.	med.	max.	min.	med.	max.
Speed									
Airflow (m ³ /h)	552	812	1010	645	923	1144	629	905	1110
Water flow rate (2) (l/h)	980			1258			1472		
Water flow rate (3) (l/h)	1079			1359			1443		
Motor Power (kW)	0,3			0,3			0,3		
Power Supply (V F Hz)	230 1 50			230 1 50			230 1 50		
IMAX (A)	1,25			1,25			1,25		
Sound Pressure (4) (dB(A))	34	43	51	35	44	50	35	44	50
Static Pressure (Pa)	100			100			100		
Water pressure drop (2) (kPa)	25,0			28,2			27,6		
Water pressure drop (3) (kPa)	26,3			28,6			23,0		
Total cooling capacity (1) (kW)	4,19	5,11	5,70	5,46	6,57	7,31	6,41	7,73	8,56
Sensible cooling capacity (1) (kW)	2,90	3,74	4,31	3,72	4,72	5,42	4,20	5,34	6,10
Heating capacity (3) (kW)	4,36	5,51	6,28	5,59	6,96	7,90	5,95	7,42	8,39
Main coil	3R			3R			4R		

CHARACTERISTICS

HANDLING UNITS

UBP AC 2 PIPES	222			232			242		
Speed	min.	med.	max.	min.	med.	max.	min.	med.	max.
Airflow (m³/h)	1158	1786	2006	1310	1997	2232	1259	1900	547
Water flow rate (2) (l/h)	1697			2177			2539		
Water flow rate (3) (l/h)	1984			2491			2622		
Motor Power (kW)	0,6			0,6			0,6		
Power Supply (V F Hz)	230 1 50			230 1 50			230 1 50		
IMAX (A)	2,70			2,70			2,70		
Sound Pressure (4) (dB(A))	37	48	51	38	49	52	38	49	52
Static Pressure (Pa)	100			100			100		
Water pressure drop (2) (kPa)	19,0			25,0			28,2		
Water pressure drop (3) (kPa)	22,5			30,3			19,5		
Total cooling capacity (1) (kW)	7,47	9,32	9,87	9,66	11,98	12,66	11,37	14,02	21,1
Sensible cooling capacity (1) (kW)	5,45	7,24	7,80	6,91	9,11	9,79	7,77	10,17	10,87
Heating capacity (3) (kW)	8,29	10,77	11,53	10,51	13,56	14,49	11,18	14,33	15,2
Main coil	3R			3R			4R		
UBP AC 2 PIPES	322			332			342		
Speed	min.	med.	max.	min.	med.	max.	min.	med.	max.
Airflow (m³/h)	2122	2714	2997	2376	3036	3300	2268	2856	3150
Water flow rate (2) (l/h)	2383			3051			17,5		
Water flow rate (3) (l/h)	2863			3579			3821		
Motor Power (kW)	0,8			0,8			0,8		
Power Supply (V F Hz)	230 1 50			230 1 50			230 1 50		
IMAX (A)	3,90			3,90			3,90		
Sound Pressure (4) (dB(A))	46	51	53	47	52	54	47	52	54
Static Pressure (Pa)	100			100			100		
Water pressure drop (2) (kPa)	27,6			19,0			17,5		
Water pressure drop (3) (kPa)	18,2			24,9			16,5		
Total cooling capacity (1) (kW)	11,65	13,19	13,86	15,04	17,02	17,74	18,10	20,33	21,33
Sensible cooling capacity (1) (kW)	8,95	10,51	11,20	11,30	13,26	14	12,75	14,82	15,79
Heating capacity (3) (kW)	13,54	15,69	16,65	17,09	19,801	20,81	18,25	20,96	22,21
Main coil	3R			3R			4R		

CHARACTERISTICS

UBP AC 4 PIPES	124			134			224			234		
Speed	min.	med.	max.	min.	med.	max.	min.	med.	max.	min.	med.	max.
Airflow (m ³ /h)	539	795	1155	628	902	1105	1128	1704	1907	1259	1885	2092
Water flow rate (2) (l/h)	959			1230			1641			2087		
Water flow rate (3) (l/h)	300			325			531			565		
Motor Power (kW)	0,3			0,3			0,6			0,6		
Power Supply (V F Hz)	230 1 50			230 1 50			230 1 50			230 1 50		
IMAX (A)	1,25						2,70					
Sound Pressure (4) (dB(A))	34	43	49	35	44	50	37	48	51	38	49	52
Static Pressure (Pa)	100			100			100			100		
Water pressure drop (2) (kPa)	23,9			27,0			17,7			24,5		
Water pressure drop (3) (kPa)	8,9			10,3			7,4			8,2		
Total cooling capacity (1) (kW)	4,13	5,04	6,20	5,37	6,47	7,15	7,31	9,02	9,54	9,39	11,53	12,14
Sensible cooling capacity (1) (kW)	2,85	3,68	4,74	3,65	4,63	5,28	5,34	7	7,53	6,67	8,69	9,30
Heating capacity (3) (kW)	4,99	6,23	6,97	5,50	6,76	7,56	9,19	11,60	12,34	9,88	12,41	13,14
Main coil	3R			3R			3R			3R		
UBP AC 4 PIPES	324			334			125			135		
Speed	min.	med.	max.	min.	med.	max.	min.	med.	máx.	min.	med.	máx.
Airflow (m ³ /h)	2028	2574	2847	2268	2856	3150	530	779	953	614	874	1071
Water flow rate (2) (l/h)	2321			2964			946			1207		
Water flow rate (3) (l/h)	761			810			479			517		
Motor Power (kW)	0,8			0,8			0,3			0,3		
Power Supply (V F Hz)	230 1 50			230 1 50			230 1 50			230 1 50		
IMAX (A)	3,90						1,25					
Sound Pressure (4) (dB(A))	46	51	53	47	52	54	34	43	49	35	44	50
Static Pressure (Pa)	100			100			100			100		
Water pressure drop (2) (kPa)	13,8			19,6			23,2			26,0		
Water pressure drop (3) (kPa)	7,1			8,0			7,3			8,3		
Total cooling capacity (1) (kW)	11,38	12,84	13,49	14,62	14,42	17,24	4,08	4,97	5,50	5,29	6,34	7,02
Sensible cooling capacity (1) (kW)	8,71	10,17	10,86	10,91	12,68	13,51	2,81	3,62	4,13	3,59	4,52	5,16
Heating capacity (3) (kW)	14,65	16,74	17,70	15,70	17,86	18,84	8	9,95	11,13	8,78	44	12,02
Main coil	3R			3R			3R			3R		

CHARACTERISTICS

UBP AC 4 PIPES	225			235			325			335		
Speed	min.	med.	max.	min.	med.	max.	min.	med.	max.	min.	med.	max.
Airflow (m ³ /h)	1105	1646	1819	1250	1833	2036	1976	2508	2736	2255	2788	2993
Water flow rate (2) (l/h)	1596			2061			2259			2873		
Water flow rate (3) (l/h)	848			914			1227			1305		
Motor Power (kW)	0,6			0,6			0,8			0,8		
Power Supply (V F Hz)	230 1 50			230 1 50			230 1 50			230 1 50		
IMAX (A)	2,70						3,90					
Sound Pressure (4) (dB(A))	37	48	51	38	49	52	46	51	53	47	52	54
Static Pressure (Pa)	100			100			100			100		
Water pressure drop (2) (kPa)	16,8			23,8			13,0			18,4		
Water pressure drop (3) (kPa)	6,2			7,0			5,8			6,4		
Total cooling capacity (1) (kW)	7,21	8,83	9,28	9,36	11,38	11,98	11,16	12,58	13,13	14,50	16,13	16,70
Sensible cooling capacity (1) (kW)	5,26	6,83	7,28	6,66	8,55	9,16	8,51	9,94	10,51	10,89	12,50	13,09
Heating capacity (3) (kW)	14,91	18,68	19,73	16,16	20,06	21,26	23,82	27,21	28,55	25,93	29,18	30,34
Main coil	3R			3R			3R			3R		

(1) Water temperature 7°C/12°C, dry bulb temperature 27°C, wet bulb temperature 19°C (47% relative humidity) according to EN1397:2015

(2) Water temperature 7°C/12°C, dry bulb temperature 27°C, wet bulb temperature 19°C (47% relative humidity)

(3) Water temperature 45°C/40°C for 2-pipe units and water temperature 80°C/60°C for 4-pipe units, air temperature 20°C

(4) Sound pressure level measured at 3 m in free field conditions according to ISO 3741 - ISO 3742

DIMENSIONS UBP 2 PIPES

UBP AC H	122	132	142	222	232	242	322	332	342
L (mm)	800	800	800	1200	1200	1200	1600	1600	1600
A (mm)	760	760	760	1160	1160	1160	1560	1560	1560
B (mm)	235	235	235	235	235	235	235	235	235
Weight (kg)	37	38	40	52	54	57	68	70	73
UBP AC V	122	132	142	222	232	242	322	332	342
L (mm)	800	800	800	1200	1200	1200	1600	1600	1600
A (mm)	760	760	760	1160	1160	1160	1560	1560	1560
B (mm)	235	235	235	235	235	235	235	235	235
Weight (kg)	37	38	40	52	54	57	68	70	73

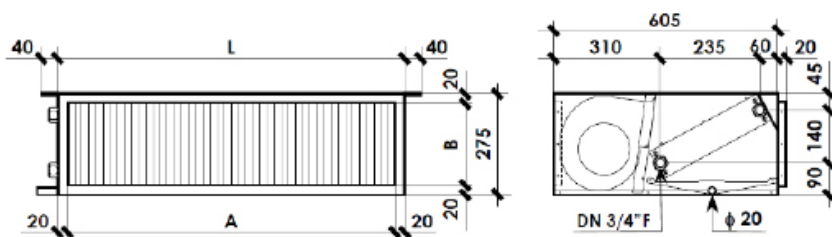

DIMENSIONS UBP 4 PIPES

UBP AC H	124	134	224	234	324	334	125	135	225	235	325	335
L (mm)	800	800	1200	1200	1600	1600	800	800	1200	1200	1600	1600
A (mm)	760	760	1160	1160	1560	1560	760	760	1160	1160	1560	1560
B (mm)	235	235	235	235	235	235	235	235	235	235	235	235
Weight (kg)	39	40	55	57	72	74	40	41	56	58	73	75
UBP AC V	124	134	224	234	324	334	125	135	225	235	325	335
L (mm)	800	800	1200	1200	1600	1600	800	800	1200	1200	1600	1600
A (mm)	760	760	1160	1160	1560	1560	760	760	1160	1160	1560	1560
B (mm)	235	235	235	235	235	235	235	235	235	235	235	235
Weight (kg)	39	40	55	57	72	74	40	41	56	58	73	75

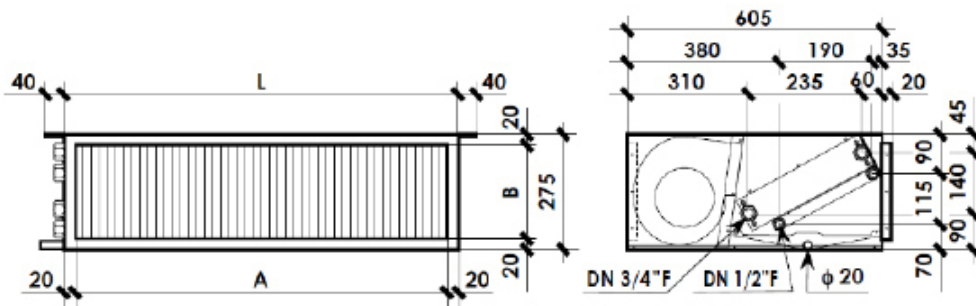

UBP PLUS EC

INDEX



350 Pa

SP up to 350 Pa

DESCRIPTION

High available static pressure ventilation and air conditioning units, model UBP PLUS EC by Arfit. Systems designed to provide efficient and flexible solutions for commercial and industrial environments. Low-profile ducted units equipped with 230 V EC brushless motors, known for their superior efficiency and silent operation.

UBP PLUS EC units feature a galvanized steel structure with internal thermal insulation, ensuring durability and efficiency.

ADVANTAGES

- Robustness, versatility, and durability.
- Reduced height, suitable for indoor duct installation with high capacity and high available static pressure. Structure designed to reduce noise levels, providing more comfortable environments.
- Installation flexibility with reversible hydraulic connections and mounting options that facilitate adaptation to site conditions.
- Possibility of integrating the Be.On module with direct cloud connection and Be.Smart monitoring.

ACCESSORIES

- Acoustic attenuators
- G3, M5, and F7 filters
- 2-way or 3-way valves with On-Off or Modulating actuator
- Auxiliary valve drain tray
- Electrical heaters
- Thermostat with ModBus communication
- Relay box

COMPONENTS

MOTOR

HEE (High Energy Efficiency) motor with high efficiency (greater than 50%) and consequent CO₂ reduction. Speed control via 0...10 Vdc signal using the CM3D or TH thermostat. 0-100% airflow modulation (and consequently heating and cooling capacity modulation) allows performance to be adjusted in real time according to the actual requirements of the conditioned space, ensuring total comfort and reduced noise levels.

COOLING COIL

Sections with cooling coils are equipped with an inclined condensate drain tray, with a 30 mm drain connection for more effective condensate removal. The condensate tray is made of galvanized steel with external thermal insulation (Class M1).

WATER COIL

Highly efficient water coil made of copper tubes with aluminum fins mechanically expanded onto the tubes. Tested at 30 bar pressure, suitable for operation with water at a maximum pressure of 15 bar. Standard connections on the right side; left-side connections are available and can be easily reversed, even on-site. Coils are suitable for operation with hot water (boilers), low-temperature hot water (condensing boilers, solar panels, heat pumps, etc.), chilled water (chillers and/or industrial processes), and water with glycol addition. Versions are available with 3-row coils, 6-row coils, and 3 + 2-row coils in the 4-pipe version.

CHARACTERISTICS
2-PIPE UNITS

UBP PLUS EC 3R 2T	4			5			6		
Speed	min.	méd.	max.	min.	méd.	max.	min.	méd.	max.
Airflow (m ³ /h)	845	1945	3050	2295	3280	4260	1485	3460	5430
Static pressure (Pa)	200			200			200		
Motor Power (kW)	1,1			1,0			2,2		
IMAX (A)	4,6			4,4			9,5		
Sound Pressure (dB(A))	29	42	51	43	50	56	33	47	57
Total cooling capacity (kW)	6,99	11,82	15,40	13,70	16,99	19,78	12,48	21,27	27,73
Sensible cooling capacity (kW)	4,84	9,04	12,54	10,25	13,32	16,10	8,58	16,16	22,44
Water outlet temperature during cooling mode (°C)*	9,3	10,8	12	10,5	11,3	12	9,3	10,8	12
Water flow rate (l/h)	2648			3402			4770		
Water pressure drop (kPa)	22,6			22,4			28,5		
Heating capacity (kW)	7,42	13,45	18,34	15,26	19,59	23,44	12,99	23,75	32,41
Water outlet temperature during heating mode (°C)**	43	41,3	40	41,8	40,8	40	43	41,3	40
Water flow rate(l/h)	3155			4031			5575		
Water pressure drop (kPa)	27,9			27,3			33,8		
Main coil	3R			3R			3R		

UBP PLUS EC 3R 2T	12			13			14		
Speed	min.	méd.	max.	min.	méd.	max.	min.	méd.	max.
Airflow (m ³ /h)	1800	3400	5000	1770	3840	5900	1690	3890	6100
Static pressure (Pa)	200			200			200		
Motor Power (kW)	2,2			2,2			2,2		
IMAX (A)	9,2			9,2			9,2		
Sound Pressure (dB(A))	36	48	57	34	47	57	32	45	54
Total cooling capacity (kW)	12,95	19,23	24,10	14,21	23,10	29,74	13,97	23,63	30,79
Sensible cooling capacity (kW)	9,51	15,27	20,20	9,95	17,76	24,27	6,72	18,14	25,17
Water outlet temperature during cooling mode (°C)*	9,7	11	12	9,4	10,9	12	9,3	10,8	12
Water flow rate (l/h)	4145			5115			5296		
Water pressure drop (kPa)	25,8			26,8			23,8		
Heating capacity (kW)	14,37	22,55	29,40	15,07	26,14	35,15	14,75	26,73	36,46
Water outlet temperature during heating mode (°C)**	42,6	41,2	40	42,9	41,3	40	43	41,3	40
Water flow rate (l/h)	5057			6046			6271		
Water pressure drop (kPa)	33,3			32,5			29		
Main coil	3R			3R			3R		

*Cooling water inlet temperature at 7°C.

**Heating water inlet temperature at 45°C.

CHARACTERISTICS

2-PIPE UNITS

UBP PLUS EC 6R 2T	4			5			6		
Speed	min.	méd.	max.	min.	méd.	max.	min.	méd.	max.
Airflow (m³/h)	845	1945	3050	2295	3280	4260	1485	3460	5430
Static pressure (Pa)	200			200			200		
Motor Power (kW)	1,1			1,0			2,2		
IMAX (A)	4,6			4,4			9,5		
Sound Pressure (dB(A))	29	42	51	43	50	56	33	47	57
Total cooling capacity (kW)	9,00	17,62	24,63	19,75	25,99	31,49	15,61	30,89	43,21
Sensible cooling capacity (kW)	5,80	12,08	17,67	13,27	18,03	22,47	10,02	21,08	30,88
Water outlet temperature during cooling mode (°C)*	8,8	10,6	12	10,1	11,1	12	8,8	10,6	12
Water flow rate (l/h)	4237			5416			7433		
Water pressure drop (kPa)	25,1			25,5			27,5		
Heating capacity (kW)	8,01	16,69	24,43	18,40	15,02	31,17	13,83	29,12	42,67
Water outlet temperature during heating mode (°C)**	43,4	41,6	40	42,1	41	40	43,4	41,6	40
Water flow rate (l/h)	4202			5362			7340		
Water pressure drop (kPa)	21,4			21,7			23,3		
Main coil	6R			6R			6R		

UBP PLUS EC 6R 2T	12			13			14		
Speed	min.	méd.	max.	min.	méd.	max.	min.	méd.	max.
Airflow (m³/h)	1800	3400	5000	1770	3840	5900	1690	3890	6100
Static pressure (Pa)	200			200			200		
Motor Power (kW)	2,2			2,2			2,2		
IMAX (A)	9,2			9,2			9,2		
Sound Pressure (dB(A))	36	48	57	34	47	57	32	45	54
Total cooling capacity (kW)	18,28	30,28	40,30	18,68	34,78	47,87	17,86	34,99	48,91
Sensible cooling capacity (kW)	12,23	21,30	29,50	12,15	23,96	34,45	11,52	23,97	35,08
Water outlet temperature during cooling mode (°C)*	9,3	10,8	12	9	10,6	12	8,8	10,6	12
Water flow rate (l/h)	6932			8233			8413		
Water pressure drop (kPa)	31,3			31			26,6		
Heating capacity (kW)	17,10	29,81	41,30	16,76	33,09	47,60	15,92	33,16	48,56
Water outlet temperature during heating mode (°C)**	42,9	41,4	40	43,2	41,5	40	43,4	41,6	40
Water flow rate (l/h)	7104			8188			8352		
Water pressure drop (kPa)	28,5			26,6			22,8		
Main coil	6R			6R			6R		

*Cooling water inlet temperature at 7°C.

**Heating water inlet temperature at 45°C.

CHARACTERISTICS
4-PIPE UNITS

UBP PLUS EC 3R+2R 4T	4			5			6		
Speed	min.	méd.	max.	min.	méd.	max.	min.	méd.	max.
Airflow (m ³ /h)	845	1945	3050	2295	3280	4260	1485	3460	5430
Static pressure (Pa)	200			200			200		
Motor Power (kW)	1,1			1,0			2,2		
IMAX (A)	4,6			4,4			9,5		
Sound Pressure (dB(A))	29	42	51	43	50	56	33	47	57
Total cooling capacity (kW)	6,99	11,92	15,40	13,70	16,99	19,78	12,48	21,27	27,73
Sensible cooling capacity (kW)	4,84	9,04	12,54	10,25	13,32	16,10	8,58	16,16	22,44
Water outlet temperature during cooling mode (°C)*	9,3	10,8	12	10,5	11,3	12	9,3	10,8	12
Water flow rate (l/h)	2648			3402			4770		
Water pressure drop (kPa)	22,6			22,4			28,5		
Heating capacity (kW)	13,18	22,10	28,95	25,03	31,10	36,35	23,05	38,93	51,03
Water outlet temperature during heating mode (°C)**	65,5	62,4	60	63,1	61,5	60	65,5	62,4	60
Water flow rate (l/h)	2490			3126			4389		
Water pressure drop (kPa)	32,2			32,7			32,7		
Main coil	3R+2R			3R+2R			3R+2R		

UBP PLUS EC 3R+2R 4T	12			13			14		
Speed	min.	méd.	max.	min.	méd.	max.	min.	méd.	max.
Airflow (m ³ /h)	1800	3400	5000	1770	3840	5900	1690	3890	6100
Static pressure (Pa)	200			200			200		
Motor Power (kW)	2,2			2,2			2,2		
IMAX do motor (A)	9,2			9,2			9,2		
Sound Pressure (dB(A))	36	48	57	34	47	57	32	45	54
Total cooling capacity (kW)	12,95	19,23	24,10	14,21	23,10	29,74	13,97	12,63	30,79
Sensible cooling capacity (kW)	9,51	15,27	20,20	9,95	17,76	24,27	9,72	18,14	25,17
Water outlet temperature during cooling mode (°C)*	9,7	11	12	9,4	10,9	12	9,3	10,8	12
Water flow rate (l/h)	4145			5115			5296		
Water pressure drop (kPa)	25,8			26,8			23,8		
Heating capacity (kW)	24,04	35,55	44,80	26,18	42,26	54,69	25,95	43,49	56,99
Water outlet temperature during heating mode (°C)**	64,7	62,1	60	65,2	62,3	60	65,5	62,4	60
Water flow rate (l/h)	3853			4703			4901		
Water pressure drop (kPa)	37,7			33,9			31		
Main coil	3R+2R			3R+2R			3R+2R		

*Cooling water inlet temperature at 7°C.

**Heating water inlet temperature at 70°C.

*Sound pressure level measured at 3 m in free field conditions according to ISO 3741 - ISO 3742.

DIMENSIONS

2-PIPE UNITS

UBP PLUS EC 3R 2T	4	5	6	12	13	14
A1 (mm)	480	550	550	425	425	480
B1 (mm)	760	1160	1360	1160	1360	1360
C1 (mm)	1160	1140	1240	995	1105	1160
D (mm)	480	550	550	425	425	480
E (mm)	680	590	690	570	680	680
F (mm)	710	1110	1310	1110	1310	1310
G (mm)	420	490	490	365	365	420
I (mm)	710	1110	1310	1110	1310	1310
L (mm)	430	500	500	375	375	430
C (mm)	30	30	30	30	30	30
U (mm)	340	295	345	285	340	340
M (mm)	100	95	95	95	95	100
N (mm)	280	360	360	235	235	280
Q (mm)	160	160	160	160	160	160
R (mm)	360	370	370	250	360	360
Weight (kg)	56	88,1	103,7	75,1	92,6	97,1

UBP PLUS EC 6R 2T	4	5	6	12	13	14
A1 (mm)	480	550	550	425	425	480
B1 (mm)	760	1160	1360	1160	1360	1360
C1 (mm)	1160	1140	1240	995	1105	1160
D (mm)	480	550	550	425	425	480
E (mm)	680	590	690	570	680	680
F (mm)	710	1110	1310	1110	1310	1310
G (mm)	420	490	490	365	365	420
I (mm)	710	1110	1310	1110	1310	1310
L (mm)	430	500	500	375	375	430
C (mm)	30	30	30	30	30	30
U (mm)	340	295	345	285	340	340
M (mm)	100	95	95	95	95	100
N (mm)	280	360	360	235	235	280
Q (mm)	160	160	160	160	160	160
R (mm)	360	370	370	250	360	360
Weight (kg)	67,4	107,1	123,7	94,1	112,6	117,1

HANDLING UNITS

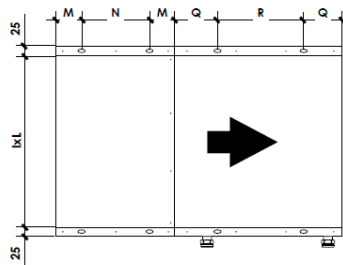
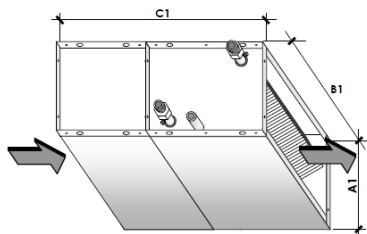
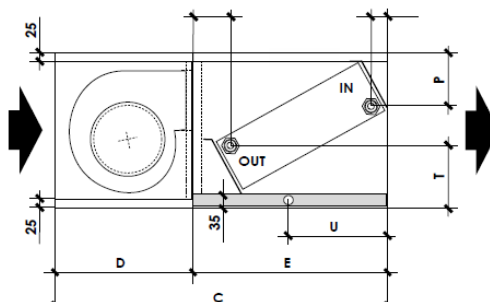
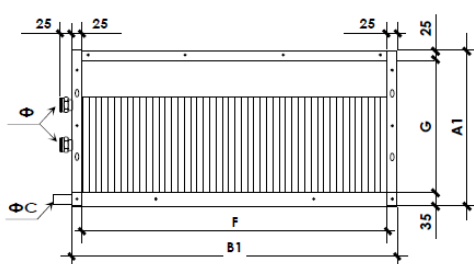

DIMENSIONS

4-PIPE UNITS

UBP PLUS EC 3R+2R 4T	4	5	6	12	13	14
A1 (mm)	480	550	550	425	425	480
B1 (mm)	760	1160	1360	1160	1360	1360
C1 (mm)	1160	1140	1240	995	1105	1160
D (mm)	480	550	550	425	425	480
E (mm)	680	590	690	570	680	680
F (mm)	710	1110	1310	1110	1310	1310
G (mm)	420	490	490	365	365	420
I (mm)	710	1110	1310	1110	1310	1310
L (mm)	430	500	500	375	375	430
C (mm)	30	30	30	30	30	30
U (mm)	340	295	345	285	340	340
M (mm)	100	95	95	95	95	100
N (mm)	280	360	360	235	235	280
Q (mm)	160	160	160	160	160	160
R (mm)	360	370	370	250	360	360
Weight (kg)	67,2	104,7	123,8	89,5	110,8	119,5

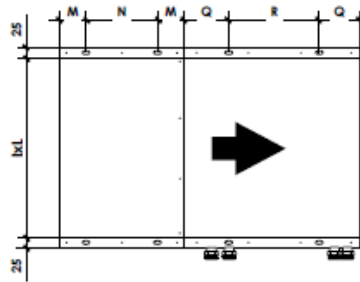
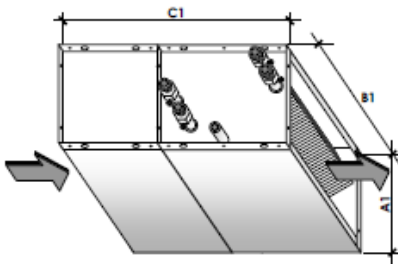
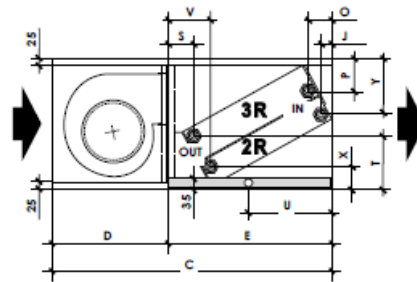
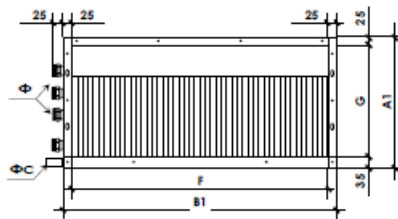

UBP PLUS AC

INDEX



DESCRIPTION

High available static pressure ventilation and air conditioning units, model UBP PLUS AC by Arfit. Systems designed to provide efficient and flexible solutions for commercial and industrial environments. Low-profile ducted units equipped with 230 V single-phase AC motors with 3 speeds.

UBP PLUS AC units feature a galvanized steel structure with internal thermal insulation, ensuring durability and efficiency.

Airflows from 3500 to 6000 m³/h. ESP up to 350 Pa. Available in versions with 3-row or 6-row coils for 2-pipe systems, and 3R+2R coils for 4-pipe systems. Hydraulic connections on the right side (standard) or left side, with reversible configuration available.

ADVANTAGES

- Robustness, versatility, and durability.
- Reduced height, suitable for indoor duct installation with high capacity and high available static pressure.
- Structure designed to reduce noise levels, providing more comfortable environments.
- Installation flexibility with reversible hydraulic connections and mounting options that facilitate adaptation to site conditions.
- Possibility of integrating the Be.On module with direct cloud connection and Be.Smart monitoring.

ACCESSORIES

- Acoustic attenuators
- G3, M5, and F7 filters
- 2-way or 3-way valves with On-Off or Modulating actuator
- Auxiliary valve drain tray
- Electrical heaters
- Thermostat with ModBus communication
- Relay box

COMPONENTS

MOTOR

Single-phase AC motor with 3 speeds and 230 V power supply. Double-inlet centrifugal fan with forward-curved aluminum blades, directly coupled to the motor. Manufactured in accordance with international standards, mounted on elastic anti-vibration supports, and statically and dynamically balanced. Easy removal (fixed with only 4 screws).

COOLING COIL

Sections with cooling coils are equipped with an inclined condensate drain tray, with a 30 mm drain connection for more effective condensate removal. The condensate tray is made of galvanized steel with external thermal insulation (Class M1).

WATER COIL

Highly efficient water coil made of copper tubes with aluminum fins mechanically expanded onto the tubes. Tested at 30 bar pressure, suitable for operation with water at a maximum pressure of 15 bar. Standard connections on the right side; left-side connections are available and can be easily reversed, even on-site. Coils are suitable for operation with hot water (boilers), low-temperature hot water (condensing boilers, solar panels, heat pumps, etc.), chilled water (chillers and/or industrial processes), and water with glycol addition. Versions are available with 3-row coils, 6-row coils, and 3 + 2-row coils in the 4-pipe version.

CHARACTERISTICS
2-PIPE UNITS

UBP PLUS AC 3R 2T	4			5			6		
Speed	min.	méd.	max.	min.	méd.	max.	min.	méd.	max.
Airflow (m ³ /h)	2046	2664	3379	3182	3689	4233	3459	4147	4556
Static pressure (Pa)	200			200			200		
Motor Power (kW)	1,6			1,7			2,1		
IMAX (A)	7			7,2			9		
Sound Pressure (dB(A))	43	47	53	48	52	58	47	51	57
Total cooling capacity (kW)	12,33	14,44	16,58	16,68	18,19	19,69	20,82	23,16	24,44
Sensible cooling capacity (kW)	9,44	11,46	13,61	13,03	14,50	16,02	15,97	18,22	19,50
Water outlet temperature during cooling mode (°C)*	10,7	11,4	12	11,2	11,6	12	11,3	11,7	12
Water flow rate (l/h)	2851			3387			4204		
Water pressure drop (kPa)	26,2			22,2			22,1		
Heating capacity (kW)	14,01	16,84	19,82	19,18	21,23	23,32	23,51	26,63	28,29
Water outlet temperature during heating mode (°C)**	41,5	40,8	40	40,9	40,5	40	40,9	40,3	40
Water flow rate (l/h)	3409			4012			4883		
Water pressure drop (kPa)	32,5			27			25,9		
Main coil	3R			3R			3R		

UBP PLUS AC 3R 2T	12			13			14		
Speed	min.	méd.	max.	min.	méd.	max.	min.	méd.	max.
Airflow (m ³ /h)	2608	3647	4819	2528	3502	5220	4092	5327	6759
Static pressure (Pa)	200			200			200		
Motor Power (kW)	2,3			2,3			3,2		
IMAX (A)	10			10			14		
Sound Pressure (dB(A))	45	51	57	43	48	57	46	50	56
Total cooling capacity (kW)	16,29	19,96	23,47	17,65	21,54	27,23	24,65	28,88	33,15
Sensible cooling capacity (kW)	12,52	16,03	19,61	12,94	16,47	22,01	18,96	23,00	27,32
Water outlet temperature during cooling mode (°C)*	10,5	11,3	12	10,2	11	12	10,7	11,4	12
Water flow rate (l/h)	4037			4683			5702		
Water pressure drop (kPa)	24,4			22,5			27,6		
Heating capacity (kW)	18,68	23,62	28,60	19,36	24,34	32,05	27,85	33,47	39,39
Water outlet temperature during heating mode (°C)**	41,7	40,9	40	42	41,2	40	41,5	40,8	40
Water flow rate (l/h)	4918			5512			6776		
Water pressure drop (kPa)	31,5			27			33,9		
Main coil	3R			3R			3R		

*Cooling water inlet temperature at 7°C.

**Heating water inlet temperature at 45°C.

CHARACTERISTICS

2-PIPE UNITS

UBP PLUS AC 6R 2T	4			5			6		
Speed	min.	méd.	max.	min.	méd.	max.	min.	méd.	max.
Airflow (m³/h)	2017	2619	3331	3132	3583	4087	3374	4058	4453
Static pressure (Pa)	200			200			200		
Motor Power (kW)	1,6			1,7			2,1		
IMAX (A)	7			7,2			9		
Sound Pressure (dB(A))	43	47	53	48	52	58	47	51	57
Total cooling capacity (kW)	18,33	22,37	26,68	24,95	27,56	30,33	29,45	33,77	36,11
Sensible cooling capacity (kW)	12,54	15,68	19,19	17,28	19,36	21,62	20,31	23,74	25,65
Water outlet temperature during cooling mode (°C)*	10,4	11,2	12	11,1	11,5	12	11,1	11,7	12
Water flow rate (l/h)	4589			5217			6211		
Water pressure drop (kPa)	29,4			23,7			19,2		
Heating capacity (kW)	17,31	21,65	26,51	23,98	26,87	30,00	28,12	32,87	35,52
Water outlet temperature during heating mode (°C)**	41,7	40,9	40	41	40,5	40	41	40,4	40
Water flow rate (l/h)	4559			5160			6109		
Water pressure drop (kPa)	25,2			20,1			16,1		
Main coil	6R			6R			6R		

UBP PLUS AC 6R 2T	12			13			14		
Speed	min.	méd.	max.	min.	méd.	max.	min.	méd.	max.
Airflow (m³/h)	2492	3442	4325	2499	3443	5085	4034	5237	6662
Static pressure (Pa)	200			200			200		
Motor Power (kW)	2,3			2,3			3,2		
IMAX (A)	10			10			14		
Sound Pressure (dB(A))	45	51	57	43	48	57	46	50	56
Total cooling capacity (kW)	23,36	29,90	35,35	24,41	31,34	41,84	36,40	44,41	52,97
Sensible cooling capacity (kW)	16,12	21,26	25,76	16,35	21,57	29,98	24,89	31,12	38,10
Water outlet temperature during cooling mode (°C)*	10,3	11,2	12	9,9	10,7	12	10,4	11,2	12
Water flow rate (l/h)	6079			7197			9111		
Water pressure drop (kPa)	24			23,7			31,2		
Heating capacity (kW)	22,59	29,81	36,12	22,60	29,84	41,49	34,41	43,03	52,68
Water outlet temperature during heating mode (°C)**	41,9	40,9	40	42,3	41,4	40	41,7	40,9	40
Water flow rate (l/h)	6212			7136			9061		
Water pressure drop (kPa)	21,8			20,2			26,8		
Main coil	6R			6R			6R		

*Cooling water inlet temperature at 7°C.

**Heating water inlet temperature at 45°C.

CHARACTERISTICS
4-PIPE UNITS

UBP PLUS AC 3R+2R 4T	4			5			6		
Speed	min.	méd.	max.	min.	méd.	max.	min.	méd.	max.
Airflow (m ³ /h)	2017	2619	3331	3132	3583	4087	3374	4058	4453
Static pressure (Pa)	200			200			200		
Motor Power (kW)	1,6			1,7			2,1		
IMAX (A)	7			7,2			9		
Sound Pressure (dB(A))	43	47	53	48	52	58	47	51	57
Total cooling capacity (kW)	12,20	14,27	16,41	16,45	17,80	19,20	20,46	22,79	24,04
Sensible cooling capacity (kW)	9,34	11,31	13,46	12,85	14,16	15,58	15,66	17,90	19,14
Water outlet temperature during cooling mode (°C)*	10,7	11,4	12	11,3	11,6	12	11,3	11,7	12
Water flow rate (l/h)	2822			3303			4135		
Water pressure drop (kPa)	25,7			21,1			21,4		
Heating capacity (kW)	25,72	29,84	34,09	33,91	36,55	39,31	42,65	47,28	49,75
Water outlet temperature during heating mode (°C)**	65	62,6	60	62,8	61,4	60	62,9	61	60
Water flow rate (l/h)	1466			1690			2139		
Water pressure drop (kPa)	10,9			9,3			7,6		
Main coil	3R+2R			3R+2R			3R+2R		

UBP PLUS AC 3R+2R 4T	12			13			14		
Speed	min.	méd.	max.	min.	méd.	max.	min.	méd.	max.
Airflow (m ³ /h)	2492	3442	4325	2499	3443	5085	4034	5237	6662
Static pressure (Pa)	200			200			200		
Motor Power (kW)	2,3			2,3			3,2		
IMAX (A)	10			10			14		
Sound Pressure (dB(A))	45	51	57	43	48	57	46	50	56
Total cooling capacity (kW)	15,66	19,02	21,71	17,48	21,26	26,72	24,40	28,53	32,81
Sensible cooling capacity (kW)	12,03	15,25	17,99	12,81	16,24	21,55	18,74	22,69	27,01
Water outlet temperature during cooling mode (°C)*	10,6	11,4	12	10,3	11	12	10,7	11,4	12
Water flow rate (l/h)	3734			4596			5643		
Water pressure drop (kPa)	20,9			21,6			27,1		
Heating capacity (kW)	33,17	39,86	45,24	36,83	44,32	55,10	50,63	58,73	67,11
Water outlet temperature during heating mode (°C)**	65,4	62,4	60	66,7	64	60	65	62,6	60
Water flow rate (l/h)	1945			2369			2886		
Water pressure drop (kPa)	9,4			8,4			10,5		
Main coil	3R+2R			3R+2R			3R+2R		

*Cooling water inlet temperature at 7°C.

**Heating water inlet temperature at 80°C.

*Sound pressure level measured at 3 m in free field conditions

DIMENSIONS

2-PIPE UNITS

UBP PLUS AC 3R 2T	4	5	6	12	13	14
A1 (mm)	480	550	550	425	425	480
B1 (mm)	760	1160	1360	1160	1360	1360
C1 (mm)	1160	1140	1240	995	1105	1160
D (mm)	480	550	550	425	425	480
E (mm)	680	590	690	570	680	680
F (mm)	710	1110	1310	1110	1310	1310
G (mm)	420	490	490	365	365	420
I (mm)	710	1110	1310	1110	1310	1310
L (mm)	430	500	500	375	375	430
C (mm)	30	30	30	30	30	30
U (mm)	340	295	345	285	340	340
M (mm)	100	95	95	95	95	100
N (mm)	280	360	360	235	235	280
Q (mm)	160	160	160	160	160	160
R (mm)	360	370	370	250	360	360
Weight (kg)	58,2	89,7	105,8	74,5	92,8	101,5

UBP PLUS AC 6R 2T	4	5	6	12	13	14
A1 (mm)	480	550	550	425	425	480
B1 (mm)	760	1160	1360	1160	1360	1360
C1 (mm)	1160	1140	1240	995	1105	1160
D (mm)	480	550	550	425	425	480
E (mm)	680	590	690	570	680	680
F (mm)	710	1110	1310	1110	1310	1310
G (mm)	420	490	490	365	365	420
I (mm)	710	1110	1310	1110	1310	1310
L (mm)	430	500	500	375	375	430
C (mm)	30	30	30	30	30	30
U (mm)	340	295	345	285	340	340
M (mm)	100	95	95	95	95	100
N (mm)	280	360	360	235	235	280
Q (mm)	160	160	160	160	160	160
R (mm)	360	370	370	250	360	360
Weight (kg)	69,6	108,7	125,8	93,5	112,8	121,5

HANDLING UNITS

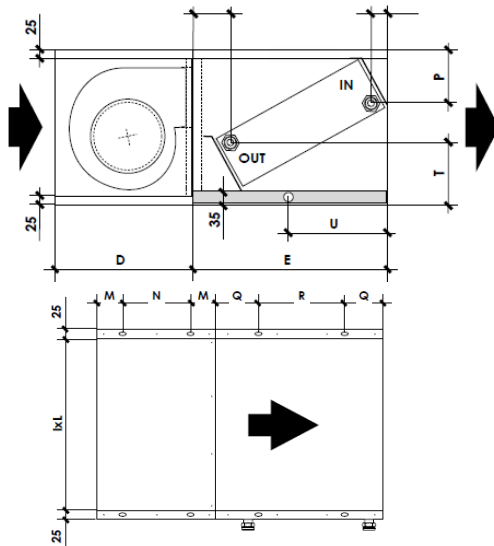
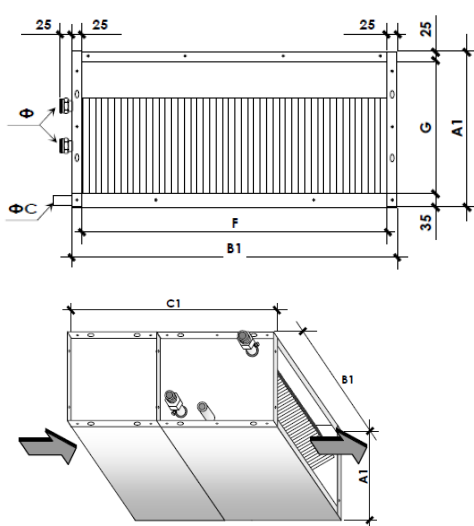

DIMENSIONS

4-PIPE UNITS

UBP PLUS AC 3R+2R 4T	4	5	6	12	13	14
A1 (mm)	480	550	550	425	425	480
B1 (mm)	760	1160	1360	1160	1360	1360
C1 (mm)	1160	1140	1240	995	1105	1160
D (mm)	480	550	550	425	425	480
E (mm)	680	590	690	570	680	680
F (mm)	710	1110	1310	1110	1310	1310
G (mm)	420	490	490	365	365	420
I (mm)	710	1110	1310	1110	1310	1310
L (mm)	430	500	500	375	375	430
C (mm)	30	30	30	30	30	30
U (mm)	340	295	345	285	340	340
M (mm)	100	95	95	95	95	100
N (mm)	280	360	360	235	235	280
Q (mm)	160	160	160	160	160	160
R (mm)	360	370	370	250	360	360
Weight (kg)	67,2	104,7	123,8	89,5	110,8	119,5

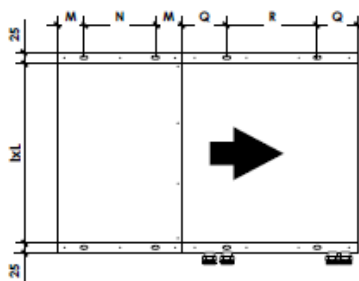
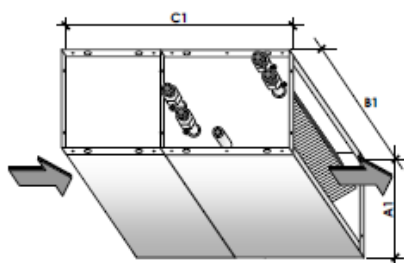
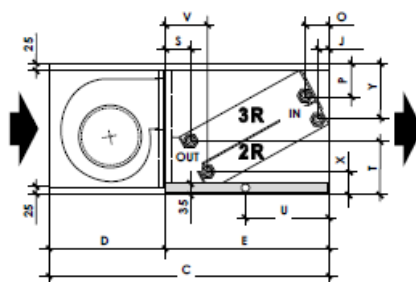
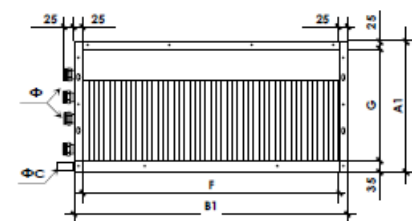

ECOAIR 2 SLIM

INDEX



EC Technology



Flexible Coil Modules



Plug & Play



Double-panel

STANDARDS AND CERTIFICATIONS



ADVANTAGES

- Compact unit designed for false ceilings.
- 25 mm double-skin insulated panels.
- Corrosion class C5.
- Low consumption electronic motor.
- Be.On module integration with cloud connection and Be.Smart monitoring.
- Flexible modular configurations: main coil module, additional coil modules, and additional 2-way mixing box.
- 3-way valve and actuator included.
- Integrated electrical panel.

ACCESSORIES

- ePM10 50% / M5 filter
- ePM1 50% / F7 filter
- Additional coil modules
- Additional 2-way mixing box
- Protection for rain (Intake / exhaust)
- Rain roof
- Constant airflow control
- CO₂ Control

DESCRIPTION

Low-profile air handling unit, ECOAIR 2 SLIM, designed for ventilation and air conditioning applications. It integrates EC Plug Fan fans, up to 2 filtration stages, and 3 types of heating and/or cooling coils.

Structure made of aluminum profiles with 25 mm double-skin panels, outer face in Magnelis with corrosion class C5 and inner face in galvanized steel sheet Z275. Intermediate insulation in high-density rock wool ensures high thermal and acoustic performance.

Compact solution available in 6 sizes, for airflow rates between 500 and 8000 m³/h. The main unit allows integration of 3 types of coils (water heating/cooling coil, refrigerant coil, or electric heating coil), with the option to incorporate additional coil modules (water or refrigerant) and a 2-way mixing box.

Equipped with Smart Evolution and Be.On control systems.

COMPONENTS

FILTERS

The filtration system consists of two stages, mounted in parallel on sliding rails designed to minimize bypass leakage, in compliance with EN 1886. It may include an ePM10 50% (M5) pre-filter for coarse particles and a standard ePM1 50% (F7) fine filter (EN 779), according to ISO 16890 classification.

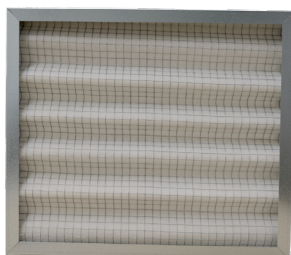

FAN

Radial EC brushless Plug Fan centrifugal fan with backward-curved blades, compact design and high available pressure. The impeller aerodynamics, balanced according to ISO 1940 G2.5 and vibration compliant with AMCA 204, combined with an EC motor class B insulation and IP44 protection, ensures high capacity, efficiency, and performance even at high system resistance.



COMPLEMENTARY MODULES

The additional modular configuration allows integration of a water coil module or refrigerant coil module, as well as a mixing box, enabling thermal flexibility and adaptation to various HVAC requirements.



CHANGE OVER COIL

Water coil that allows both heating and cooling operation using the same heat exchanger. It consists of copper tubes, aluminum fins mechanically expanded onto tubes, copper headers, and galvanized steel frame. Tightness and integrity are factory tested at 32 bar. Module equipped with stainless steel condensate drain tray. 3-way valve and actuator included.

DIRECT EXPANSION COIL

Direct expansion coil using R32 refrigerant. It consists of copper tubes, aluminum fins mechanically expanded onto tubes, copper headers, and galvanized steel frame. Tightness and integrity are factory tested at 60 bar. Module equipped with stainless steel condensate drain tray.

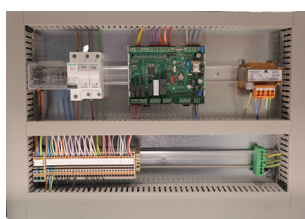

ELECTRIC HEATING COIL

Electric heater coil composed of armored heating elements in 8 mm steel tubes with 25 x 50 mm fins of the same material and quick fixing screws with M4 threaded terminals. The heaters are specifically designed for air handling applications. They are mounted in a frame and installed on a sliding rail for easy removal.

CHARACTERISTICS

ECOAIR 2 SLIM	500	1000	2000	3000	5000	8000
Airflow (m ³ /h)	500	1000	2000	3000	5000	8000
Static pressure (Pa)	575	575	657	600	875	536
Motor Power (kW)	0,2	2 x 0,20	2 x 0,33	2 x 0,37	2 x 1,1	2 x 1,4
Nominal Rotation Speed (rpm)	3000	3000	3350	2750	3500	3300
Power Supply (V F Hz)	230 1 50				400 3 50	
Motor IP Class	IP 44					
IMAX (A)	1,71	3,32	4,04	4,70	4,76	5,54
Sound Pressure (dB (A)) *	43	46	50	48	56	54

* Sound pressure level at 4 m, measured in open field in accordance with ISO 3744

CHARACTERISTICS
CHANGE OVER COIL

BCA ECOAIR 2 SLIM	Airflow (m³/h)	Heating			Cooling		
		Heating capacity (kW)	Water flow rate (l/s)	Water pressure drop (kPa)	Cooling capacity (kW)	Water flow rate (l/s)	Water pressure drop (kPa)
500	356	3	0,13	4,3	2	0,07	3,2
	436	3	0,15	4,8	2	0,10	3,7
	495	3	0,17	5,1	2	0,12	4,1
1000	719	6	0,28	7,1	5	0,22	6,1
	879	7	0,32	8,4	5	0,25	6,9
	1000	7	0,35	9,4	6	0,27	7,5
2000	1439	11	0,55	6,8	9	0,43	5,9
	1758	13	0,63	8,1	10	0,49	6,7
	1998	14	0,69	9,0	11	0,53	7,3
3000	2136	17	0,83	11,5	14	0,67	9,5
	2611	20	0,95	14,7	16	0,76	11,6
	2967	22	1,04	17,2	17	0,81	13,3
5000	3561	29	1,39	13,2	24	1,13	10,9
	4352	33	1,60	16,9	27	1,27	13,5
	4946	36	1,74	19,8	29	1,37	15,4
8000	5800	47	2,24	17,4	39	1,85	13,7
	7089	54	2,58	22,4	44	2,09	16,9
	8056	59	2,81	24,1	47	2,25	19,3

Airflow at velocities: 1.8; 2.2; 2.5 m/s

Heating - Air temperature: 0°C / 80%. Water temperature: 45°C-40°C

Cooling - Air temperature: 35°C / 50%. Water temperature: 7°C-12°C

DIRECT EXPANSION COIL

BCR ECOAIR 2 SLIM	Airflow (m³/h)	Heating capacity (kW)	Cooling capacity (kW)
500	292	2	3
	356	2	3
	405	2	4
1000	654	4	7
	800	4	7
	909	5	8
2000	1374	8	14
	1679	9	16
	1908	10	17
3000	2085	13	21
	2548	15	23
	2895	16	25
5000	3459	22	36
	4227	25	40
	4803	28	43
8000	5613	36	57
	6861	41	64
	7796	45	69

Airflow at velocities: 1.8; 2.2; 2.5 m/s

Heating - Air inlet temperature: 10°C / 55%. R32 condensation temperature: 50°C

Cooling - Air inlet temperature: 35°C / 50%. R32 evaporation temperature: -4°C

CHARACTERISTICS
ELECTRIC HEATING COIL

BRE ECOAIR 2 SLIM	Airflow (m ³ /h)	Heating capacity (kW)
500	500	3
1000	1000	6
2000	2000	14
3000	3000	24
5000	5000	36
8000	8000	54

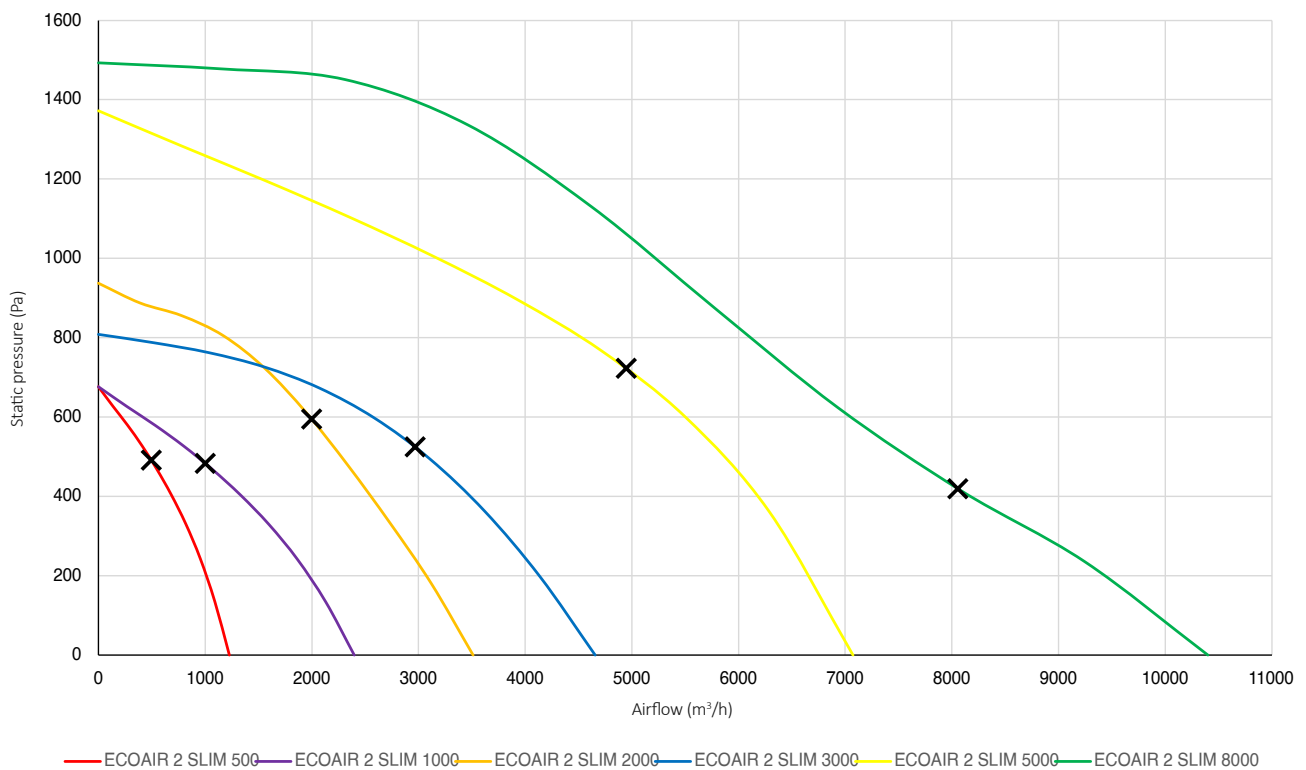
PERFORMANCE CURVES
ECOAIR 2 SLIM ePM10 50%/M5 + WATER COIL

PERFORMANCE CURVES

ECOAIR 2 SLIM ePM1 50%/F7 + WATER COIL

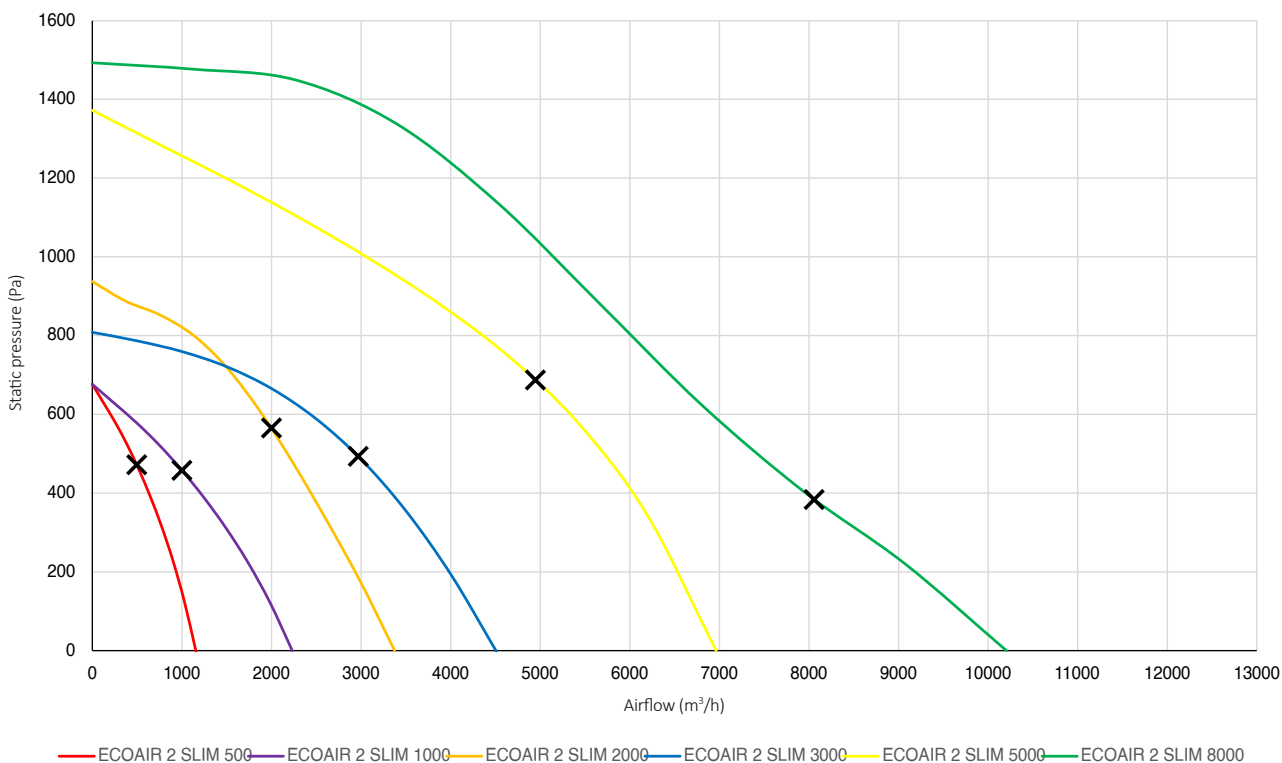

ECOAIR 2 SLIM ePM10 50%/M5 + ePM1 50%/F7 + WATER COIL

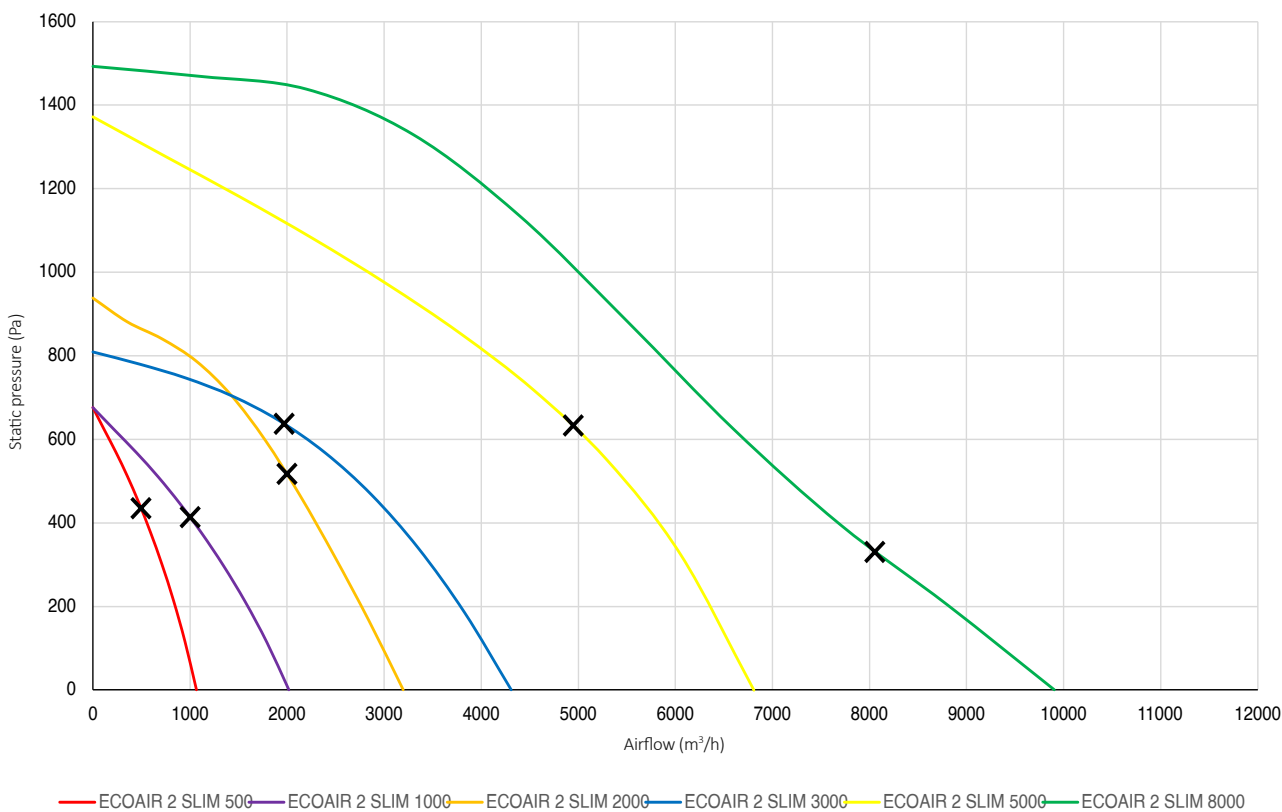

PERFORMANCE CURVES

ECOAIR 2 SLIM ePM10 50%/M5 + DX COIL

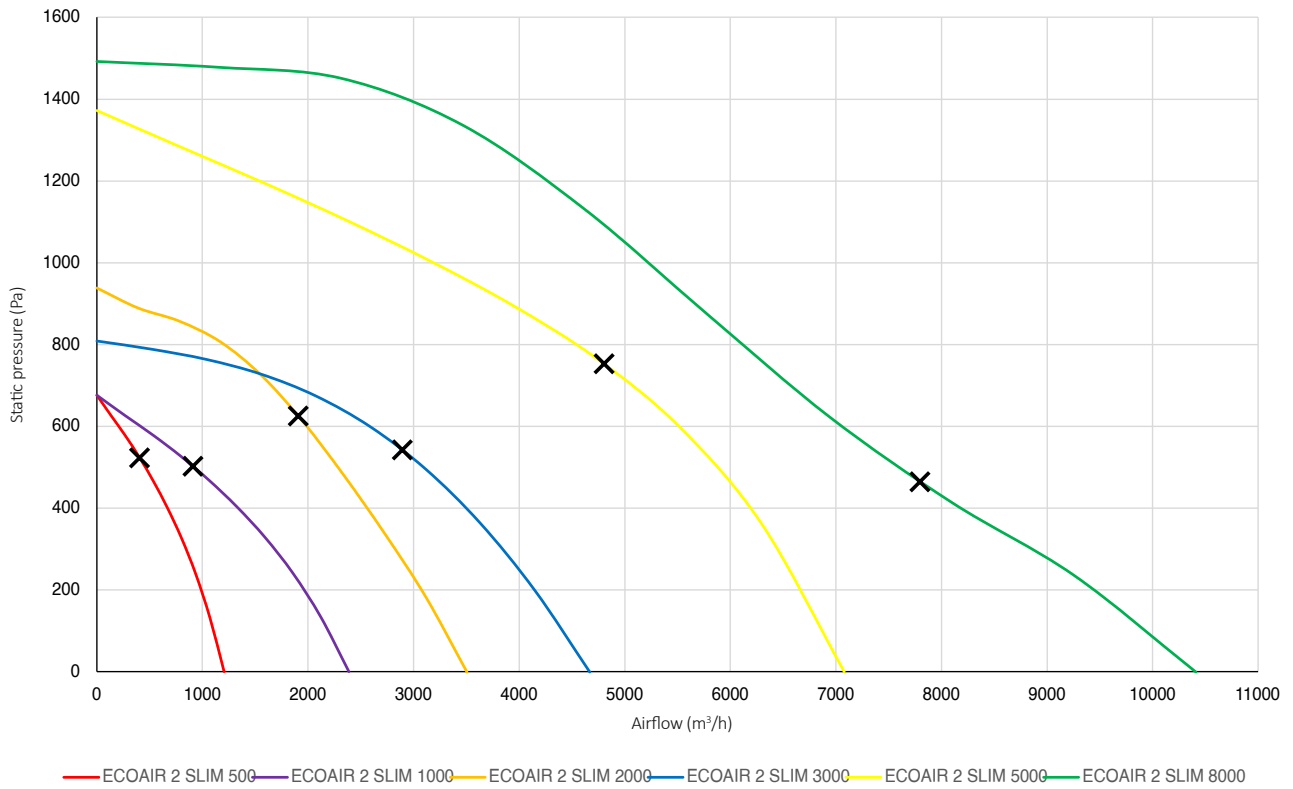

ECOAIR 2 SLIM ePM1 50%/F7 + DX COIL

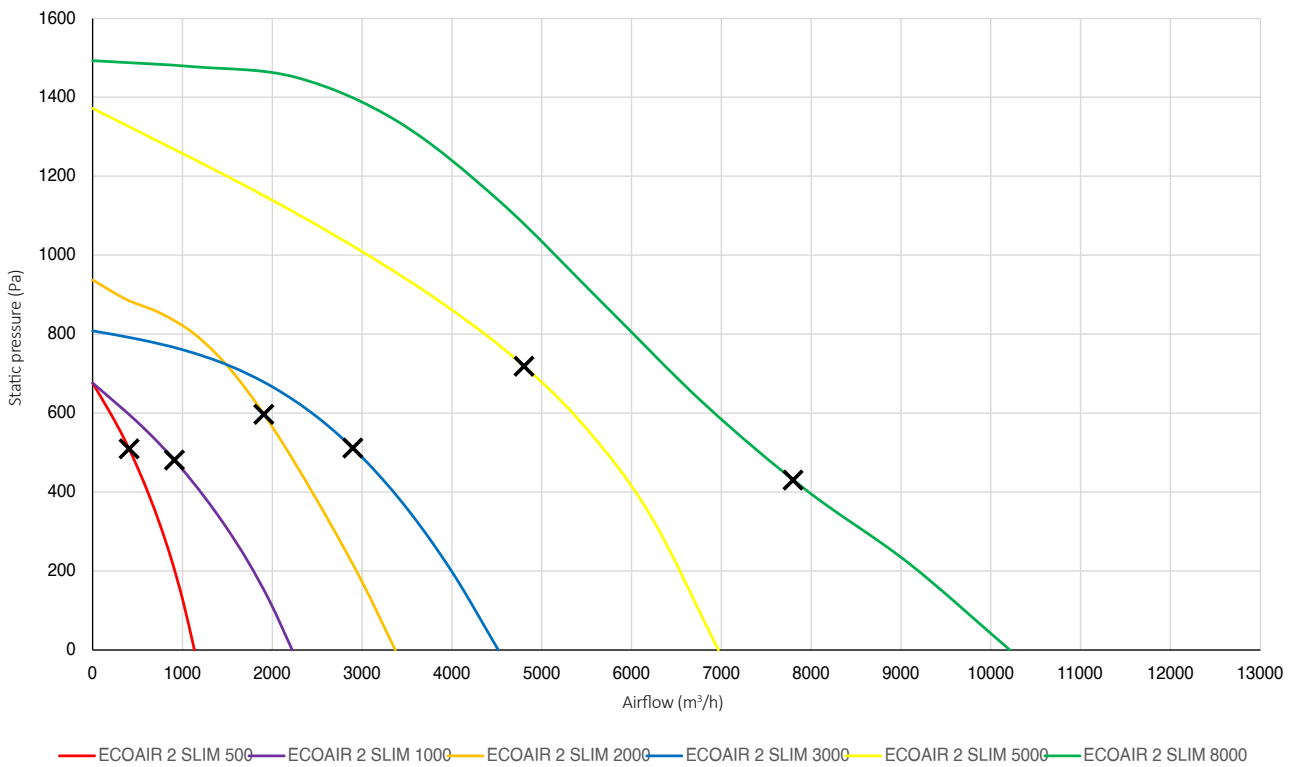

PERFORMANCE CURVES

ECOAIR 2 SLIM ePM10 50%/M5 + ePM1 50%/F7 + DX COIL

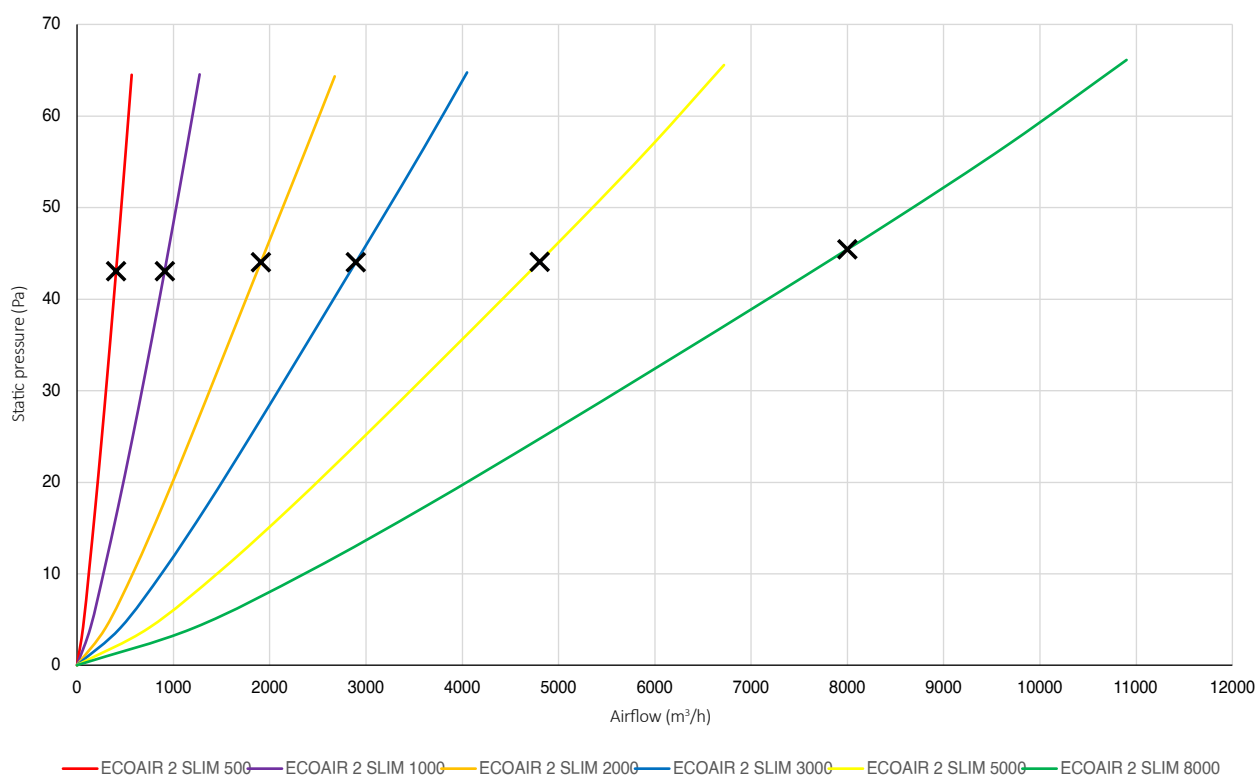

ECOAIR 2 SLIM WATER COIL

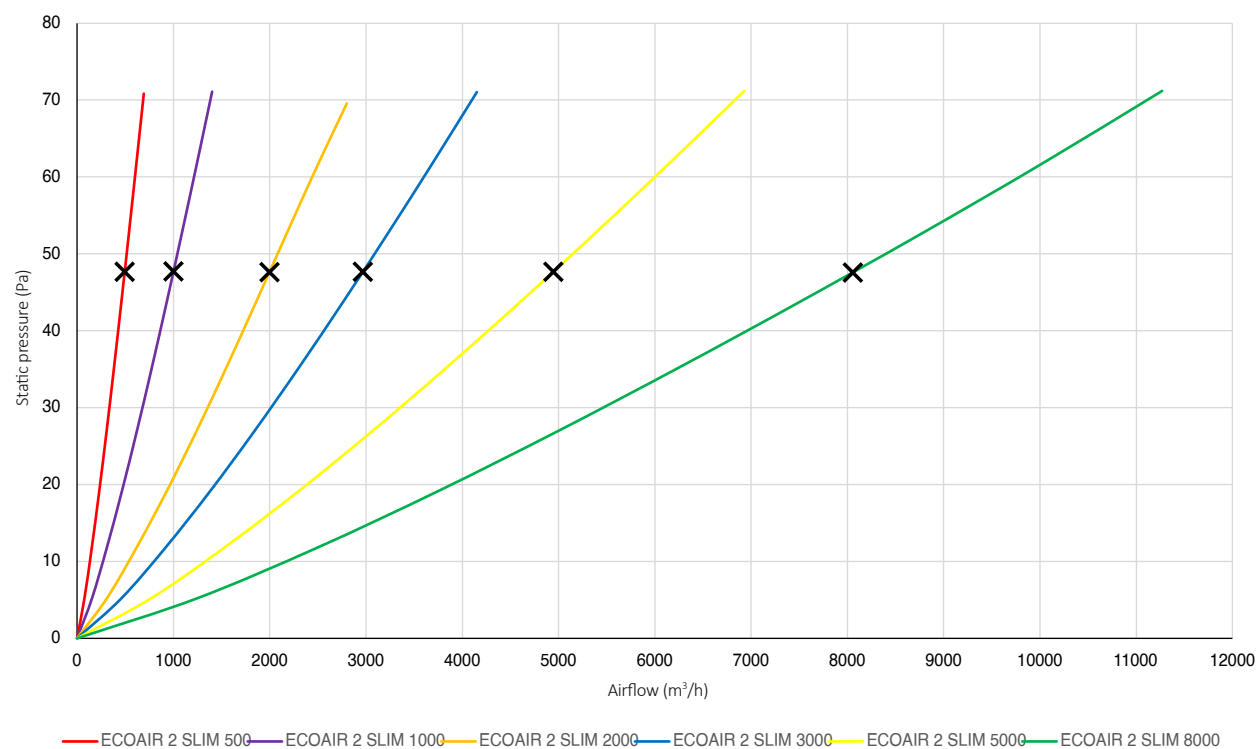

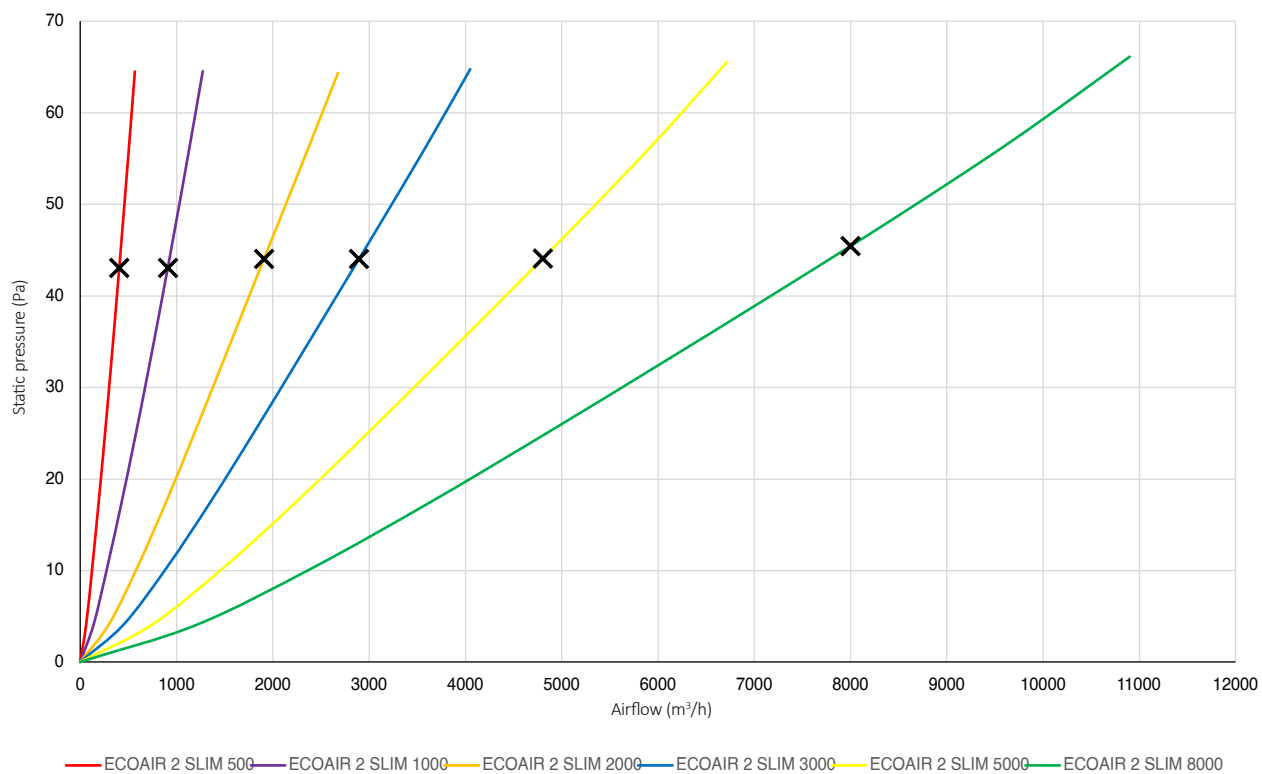
ECOAIR 2 SLIM DX COIL

WATER COIL - WATER HEATING / COOLING COIL DX COIL - DIRECT EXPANSION COIL

DIMENSIONS

ECOAIR 2 SLIM	500	1000	2000	3000	5000	8000
A (mm)	350	350	350	375	500	700
L (mm)	450	730	1285	1650	1755	1900
P (mm)	1375	1375	1450	1450	1450	1530
Rectangular Cross-Section (CxB) (mm)	390 x 290	670 x 290	1225 x 290	1590 x 315	1695 x 440	1840 x 640
Weight (kg)	5,5	11	18	21,4	36	40

COIL MODULE

ECOAIR 2 SLIM - COIL MOD	500	1000	2000	3000	5000	8000
A (mm)	350	350	350	375	500	700
L (mm)	450	730	1285	1650	1755	1900
P (mm)	450	450	450	450	450	450
Rectangular Cross-Section (CxB) (mm)	390 x 290	670 x 290	1225 x 290	1590 x 315	1695 x 440	1840 x 640

DIMENSIONS

MIXING BOX MODULE

ECOAIR 2 SLIM - MIXING BOX	500	1000	2000	3000	5000	8000
A (mm)	350	350	350	375	500	700
L (mm)	450	730	1285	1650	1755	1900
P (mm)	350	350	350	375	500	700
C/D (mm)	290	290	290	315	440	640
E (mm)	390	670	1225	1590	1695	1840
Ak (m ²)	0,11	0,19	0,36	0,50	0,75	1,18
v (m/s)	1,23	1,43	1,56	1,66	1,86	1,89

A - Height (mm)
 C - Length (mm)
 Ak - Throat area (m²)
 v - Throat velocity (m/s)

DIMENSIONS

NOTE: MAINTENANCE CLEARANCE AND UNIT ACCESS DISTANCE | 750 MM

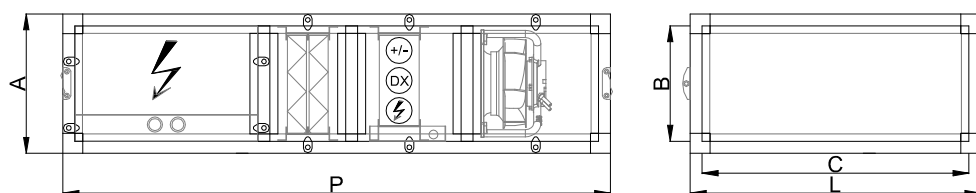

ECOAIR 2 SLIM
Main Unit

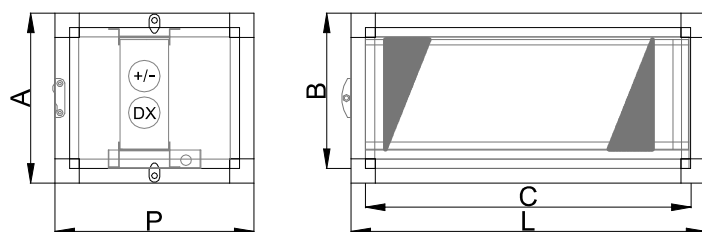

ECOAIR 2 SLIM
Coil Module

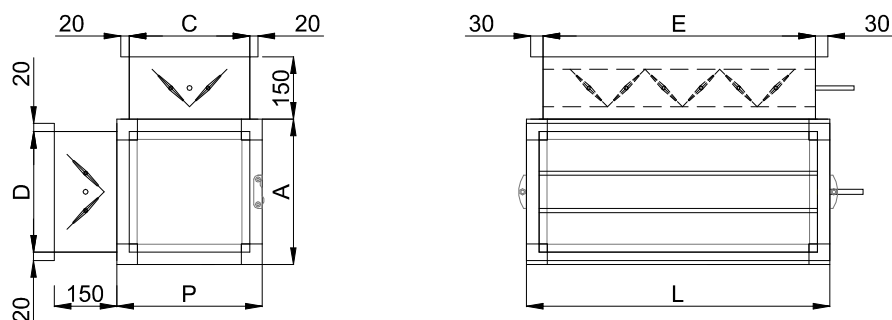

ECOAIR 2 SLIM
Mixing Box Module

CONFIGURATIONS

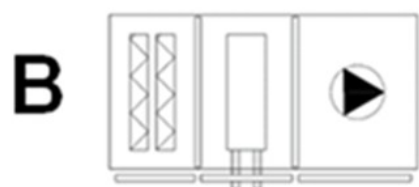
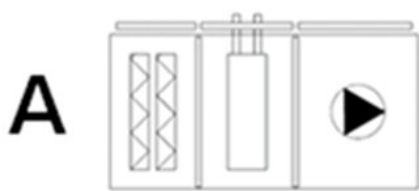

ERP VERIFICATION DOCUMENT

MANUFACTURER		ARFIT AIR CONDITIONING, S.A.					
Model		500	1000	2000	3000	5000	8000
Type		UVNR UVU					
Transmission Type		Variable Speed	Variable Speed	Variable Speed	Variable Speed	Variable Speed	Variable Speed
Heat Recovery System Type		-					
Heat Recovery Thermal Efficiency	%	-	-	-	-	-	-
Nominal Airflow	m ³ /s	0.1389	0.2778	0.5556	0.8333	1.3888	2.0000
Input Power	kW	0.186	0.372	0.83	0.952	2.464	2.886
SPFint	W/m ² /s	130.4	160.7	170.1	158.0	190.8	158.5
Frontal Velocity	m/s	1.23	1.43	1.56	1.66	1.86	1.70
Nominal External Pressure	Pa	519	506	607	517	755	624
Reduction in Internal Pressure (Ventilation)	Pa	56	69	78	83	91	77
Static Efficiency of Fans	%	42.9%	42.9%	45.9%	52.5%	47.7%	48.6%
Maximum Declared Internal/External Leakage Rate	%	-	-	-	-	-	-
Filter Classification		F7					
Description: Visual notice regarding filters		The filters warning is displayed on the unit's control system, either via a warning light or on-screen message, depending on the control system used. It is of the utmost importance to replace the filters regularly to improve the unit's performance and energy efficiency.					
Sound Power Level (Lwa)	dB(A)	44	47	51	52	56	59
Website		www.arfit.pt					

ECOAIR 2

INDEX



EC Technology



Flexible Coil Modules



Plug & Play



Double-panel

DESCRIPTION

ECOAIR 2 air handling unit. Designed for ventilation and air conditioning applications, it integrates EC Plug Fan fans, up to 2 filtration stages, and 3 types of heating and/or cooling coils.

Structure made of aluminum profiles with 25 mm double-skin panels, outer face in Magnelis with corrosion class C5 and inner face in galvanized steel sheet Z275. Intermediate insulation in high-density rock wool ensures high thermal and acoustic performance.

A high-capacity and high-performance solution available in 8 sizes, for airflow rates up to 15,000 m³/h. The main unit allows integration of 3 types of coils (water heating/cooling coil, refrigerant coil, or electric heating coil), with the option of additional coil modules (water or refrigerant) and a 2-way mixing box.

Equipped with Smart Evolution and Be.On control systems.

STANDARDS AND CERTIFICATIONS



ADVANTAGES

- High-capacity unit, suitable for large airflow rates.
- 25 mm double-skin insulated panels.
- Corrosion class C5.
- Low energy consumption EC motor.
- Be.On module integration with cloud connection and Be.Smart monitoring.
- Flexible modular configurations: main coil module, additional coil modules, and additional 2-way mixing box.
- 3-way valve and actuator included.
- Integrated electrical panel.

ACCESSORIES

- ePM10 50% / M5 filter
- ePM1 50% / F7 filter
- Additional coil modules
- 2-way mixing box
- Protection for rain (intake / exhaust)
- Rain roof
- Constant airflow control
- CO₂ Control

COMPONENTS

FILTERS

The filtration system consists of two stages, mounted in parallel on sliding rails designed to minimize bypass leakage, in accordance with EN 1886. It may include an ePM10 50% (M5) pre-filter for coarse particles and a standard ePM1 50% (F7) fine filter (EN 779), according to ISO 16890 classification.

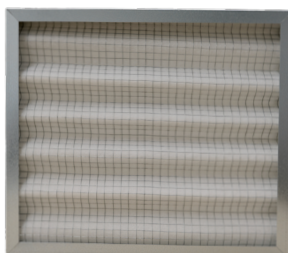

FAN

Radial EC brushless Plug Fan centrifugal fan with backward-curved blades, compact design and high available pressure. The impeller aerodynamics, balanced according to ISO 1940 G2.5 and vibration compliant with AMCA 204, combined with an EC motor class B insulation and IP44 protection, ensures high capacity, efficiency, and performance even under high resistance conditions.



COMPLEMENTARY MODULES

The additional modular configuration allows integration of a water coil module or refrigerant coil module, as well as a mixing box, providing thermal flexibility and adaptation to different HVAC requirements.



CHANGE OVER COIL

Water coil that allows switching between heating and cooling with the same coil. It consists of copper tubes, aluminum fins mechanically expanded onto tubes, copper headers, and galvanized steel structure. Tightness and integrity are factory tested at 32 bar. Module equipped with stainless steel condensate drain tray. 3-way valve and actuator included.

DIRECT EXPANSION COIL

Direct expansion coil using R32 refrigerant. It consists of copper tubes, aluminum fins mechanically expanded onto tubes, copper headers, and galvanized steel structure. Tightness and integrity are factory tested at 60 bar. Module equipped with stainless steel condensate drain tray.

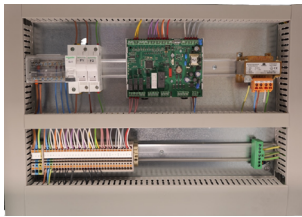

ELECTRIC HEATING COIL

Electric resistance heating coil composed of armored heating elements in 8 mm steel tubes with 25 x 50 mm fins of the same material and quick fixing screws with M4 threaded terminals. The heating elements are specifically designed for air handling applications. They are mounted in a frame and installed on a sliding rail for easy removal.

CHARACTERISTICS

ECOAIR 2	1500	2500	3500	5000	7000	10 000	12 000	15 000
Airflow (m ³ /h)	1575	2455	3620	4800	7125	9755	12 340	15 165
Static pressure (Pa)	760	827	655	975	870	672	655	752
Motor Power (kW)	0,7	1,1	1,4	2,5	2,5	2,77	2,7	2 x 2,5
Nominal Rotation Speed (rpm)	2950	3500	3300	3200	2650	1520	1250	2650
Power Supply (V F Hz)	230 1 50		400 3 50					
Motor IP Class	IP 44							
IMAX (A)	3,81	2,43	2,81	4,68	5,73	5,39	6,1	11,36
Sound Pressure (dB (A)) *	48	53	51	53	53	45	44	56

* Sound pressure level at 4 m, measured in open field in accordance with ISO 3744

CHARACTERISTICS
CHANGE OVER COIL

BCA ECOAIR 2	Airflow (m³/h)	Heating			Cooling		
		Heating capacity (kW)	Water flow rate (l/s)	Water pressure drop (kPa)	Cooling capacity (kW)	Water flow rate (l/s)	Water pressure drop (kPa)
1500	972	8	0,38	10,0	6	0,30	8,3
	1188	9	0,43	12,8	7	0,34	9,7
	1350	10	0,47	15,0	8	0,36	11,0
2500	1539	12	0,59	9,2	10	0,47	7,7
	1881	14	0,68	11,5	11	0,53	9,0
	2137	15	0,74	13,5	12	0,57	9,9
3500	2228	18	0,86	9,4	14	0,69	7,9
	2723	20	0,99	12,0	16	0,77	9,2
	3093	22	1,08	14,0	17	0,83	10,2
5000	2991	24	1,15	8,0	19	0,91	6,8
	3655	27	1,32	9,6	21	1,02	7,8
	4153	30	1,44	11,0	23	1,10	8,5
7000	4406	35	1,70	9,6	28	1,35	8,1
	5386	40	1,96	12,1	32	1,52	9,4
	6120	44	2,13	14,2	34	1,63	10,5
10 000	6114	49	2,35	6,9	38	1,83	5,9
	7473	56	2,69	8,2	43	2,06	6,6
	8491	61	2,94	9,1	47	2,22	7,2
12 000	7629	61	2,96	9,5	50	2,37	8,2
	9324	70	3,40	12,1	56	2,66	9,5
	10595	77	3,71	14,2	60	2,87	10,7
15 000	9424	76	3,66	9,7	61	2,92	8,3
	11518	87	4,20	12,4	69	3,28	9,6
	13088	95	4,58	14,5	74	3,53	10,9

Airflow at velocities: 1.8; 2.2; 2.5 m/s

Heating - Air temperature: 0°C / 80%. Water temperature: 45°C-40°C

Cooling - Air temperature: 35°C / 50%. Water temperature: 7°C-12°C

DIRECT EXPANSION COIL

BCR ECOAIR 2	Airflow (m³/h)	Heating capacity (kW)	Cooling capacity (kW)
1500	842	5	8
	1030	6	9
	1170	7	9
2500	1377	8	12
	1683	10	14
	1912	10	15
3500	2049	11	18
	2505	12	21
	2846	13	22
5000	2759	15	25
	3372	17	28
	3831	18	30
7000	4121	22	37
	5037	25	42
	5724	27	45
10 000	5838	29	53
	7136	33	60
	8109	36	64
12 000	7436	39	67
	9088	45	76
	10327	48	82
15 000	8734	46	78
	10675	52	88
	12130	56	95

Airflow at velocities: 1.8; 2.2; 2.5 m/s

Heating - Air inlet temperature: 10°C / 55%. R32 condensation temperature: 50°C

Cooling - Air inlet temperature: 35°C / 50%. R32 evaporation temperature: -4°C

CHARACTERISTICS

ELECTRIC HEATING COIL

BRE ECOAIR 2	Airflow (m ³ /h)	Heating capacity (kW)
1500	1575	12
2500	2455	18
3500	3620	27
5000	4800	36
7000	7125	54
10 000	9755	72
12 000	12 340	90
15 000	15 165	108

PERFORMANCE CURVES

ECOAIR 2 ePM10 50%/M5 + WATER COIL

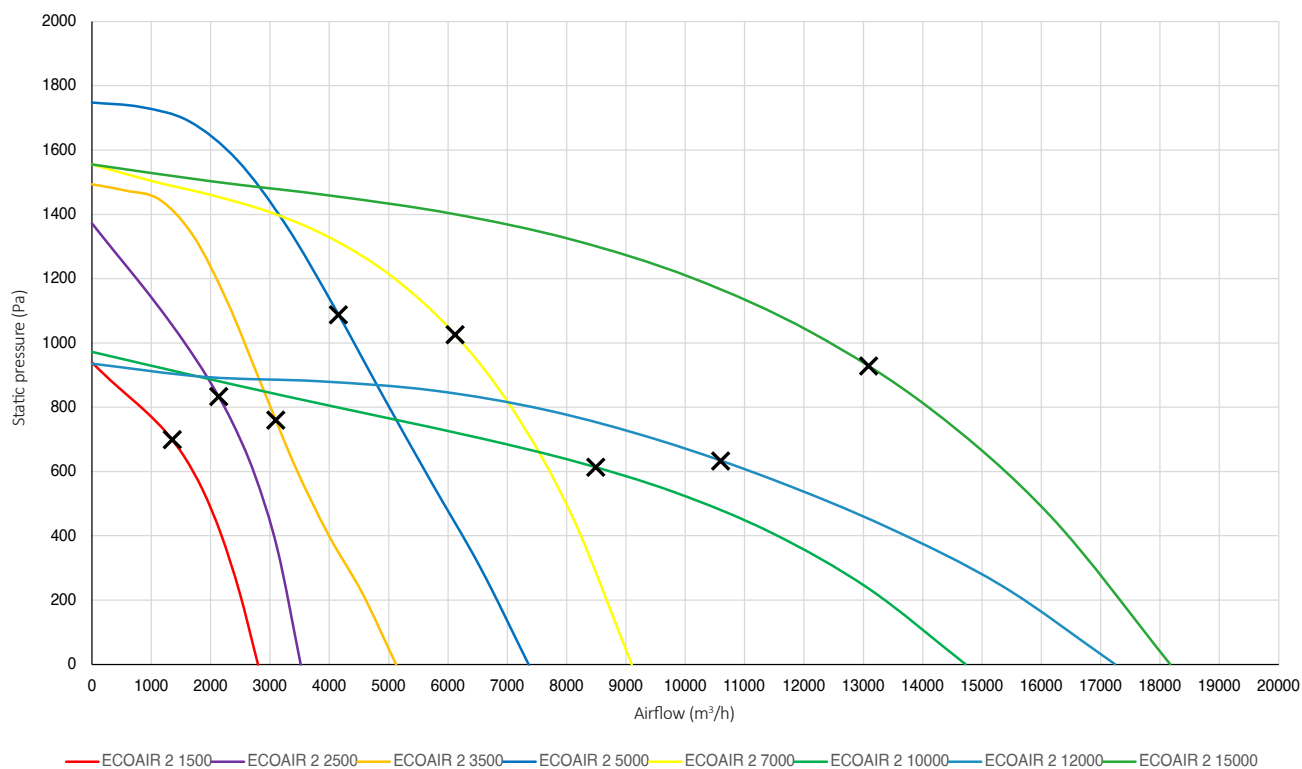

PERFORMANCE CURVES

ECOAIR 2 ePM1 50%/F7 + WATER COIL

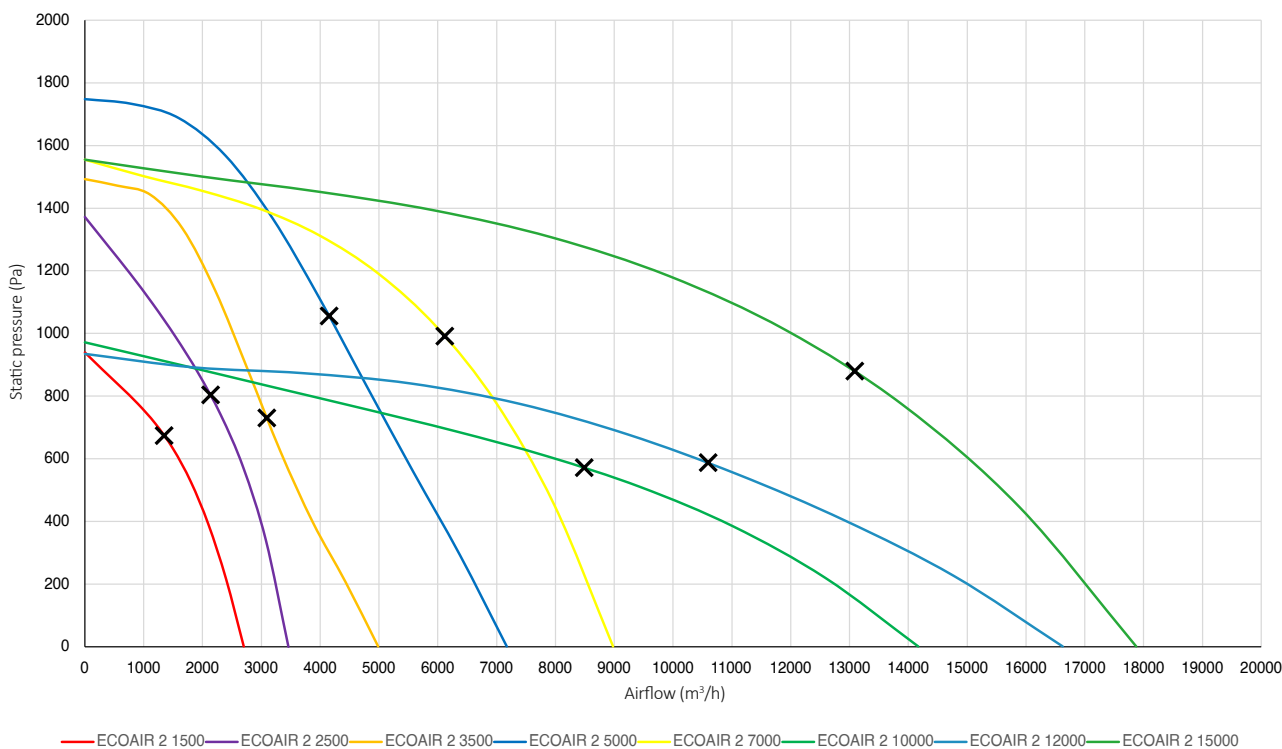

HANDLING UNITS

ECOAIR 2 ePM10 50%/M5 + ePM1 50%/F7 + WATER COIL

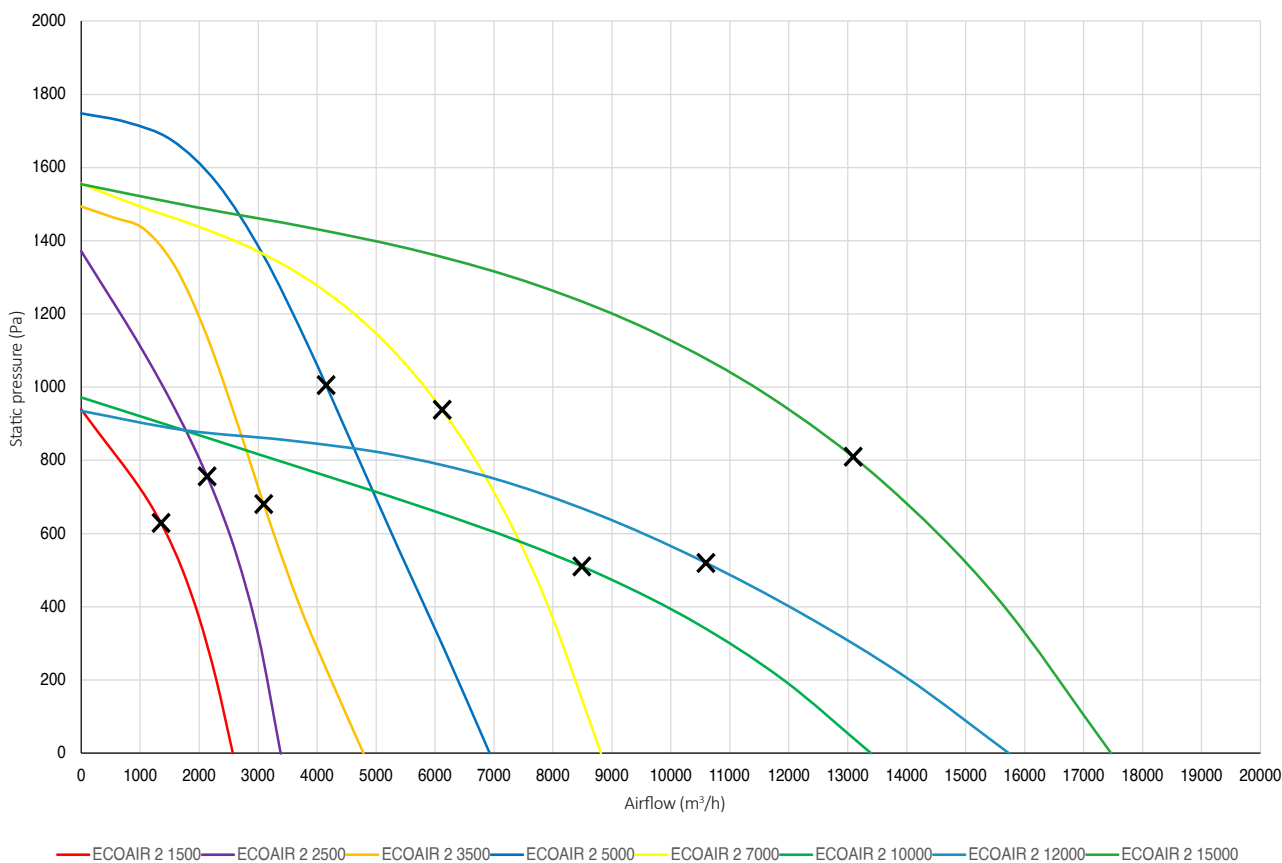

PERFORMANCE CURVES

ECOAIR 2 ePM10 50%/M5 + DX COIL

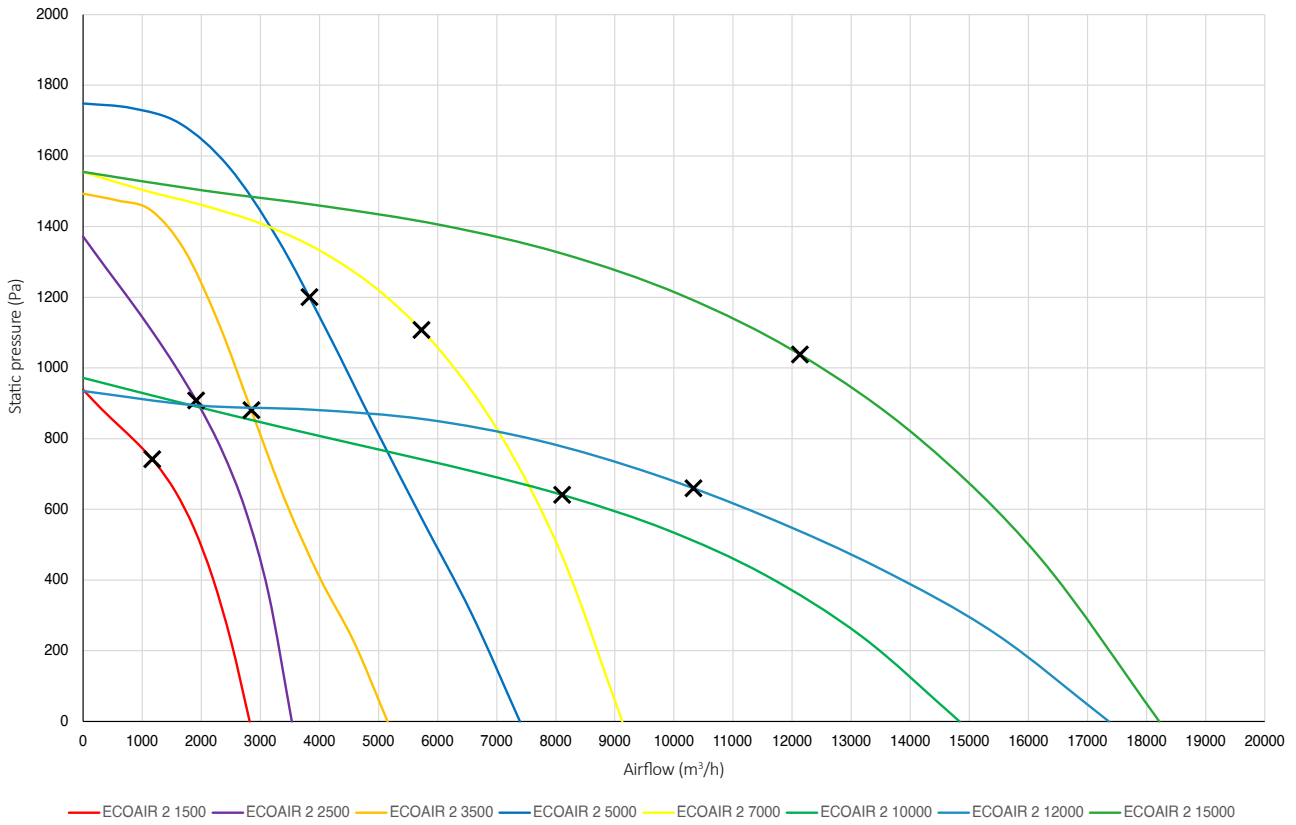

ECOAIR 2 ePM10 50%/F7 + DX COIL

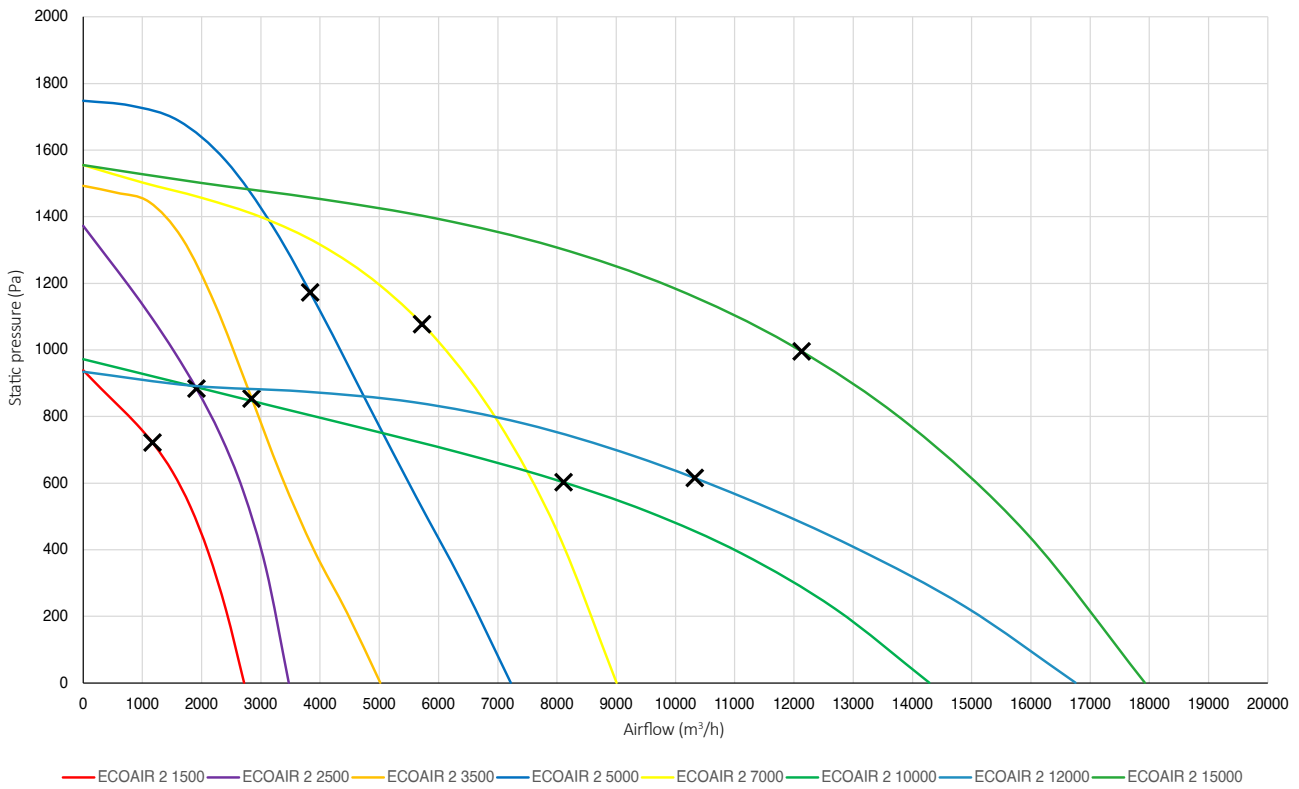

PERFORMANCE CURVES

ECOAIR 2 ePM10 50%/M5 + ePM1 50%/F7 + DX COIL

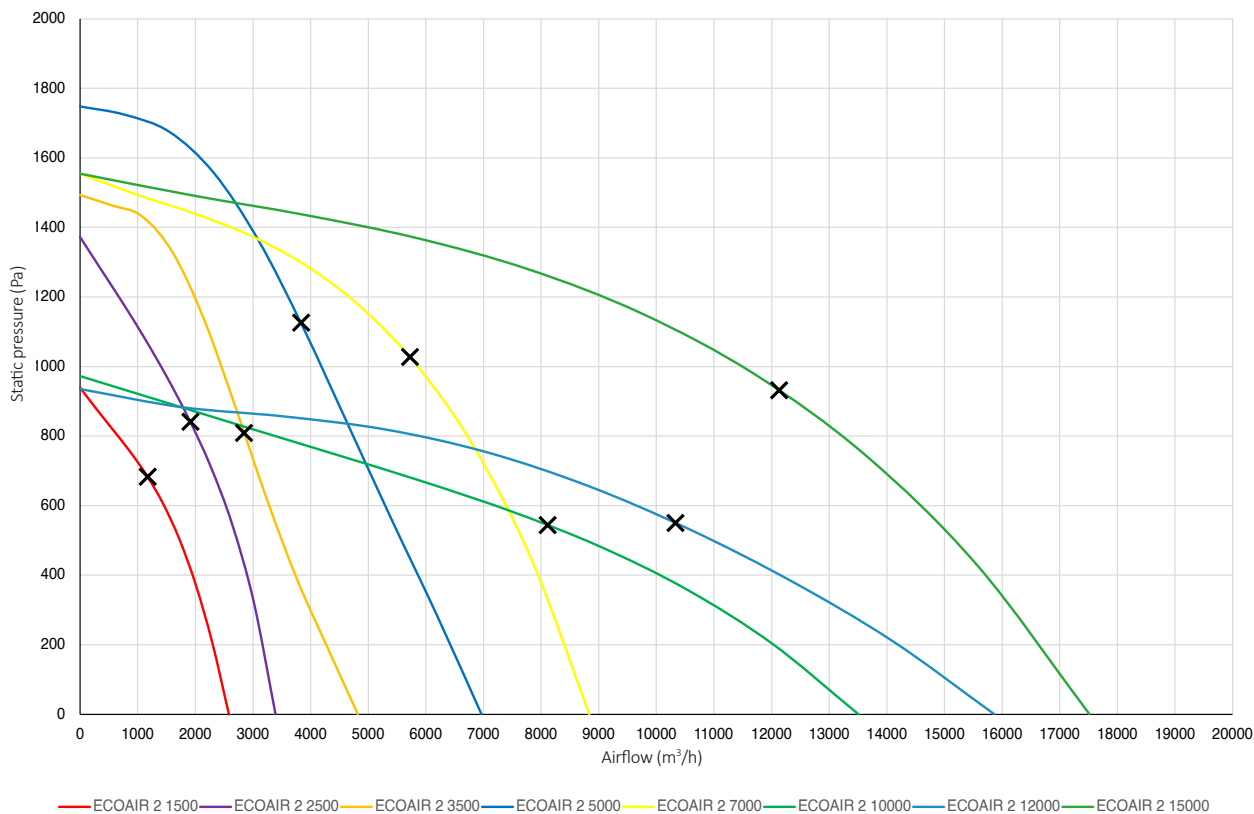

ECOAIR 2 WATER COIL MOD

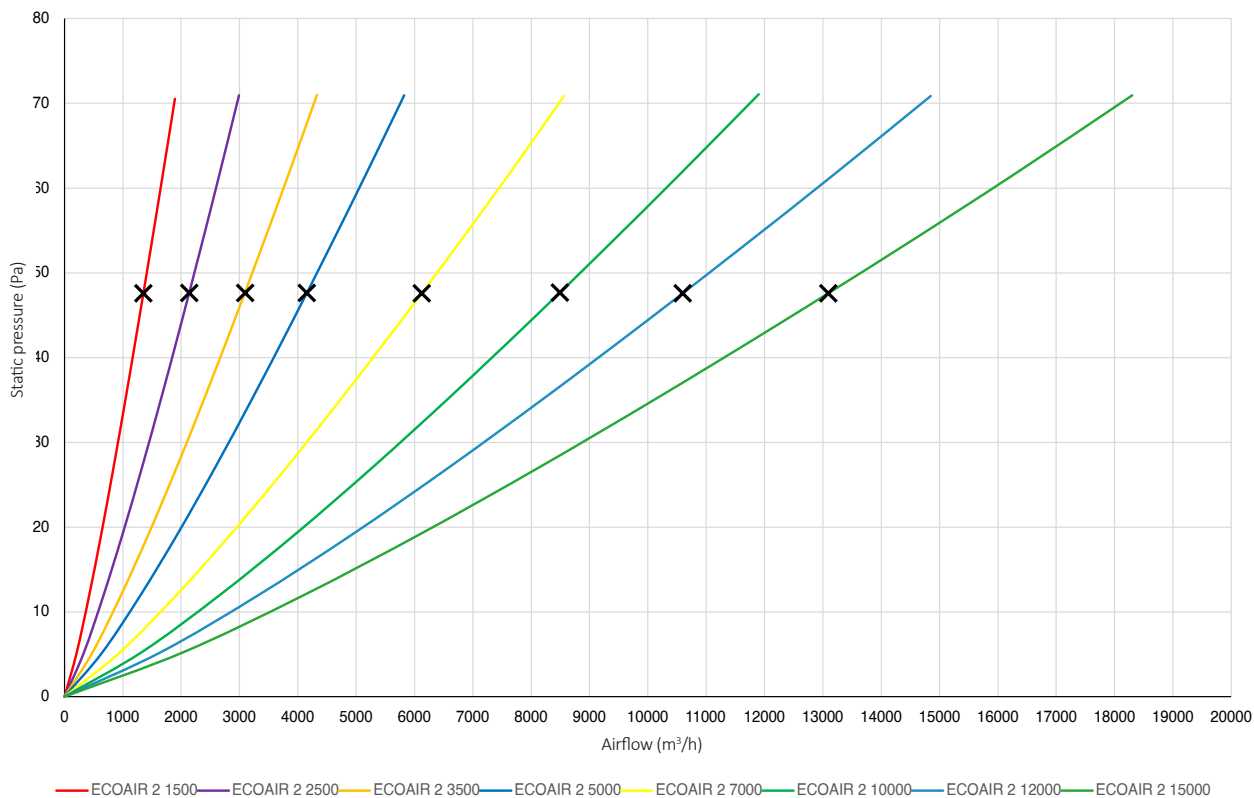

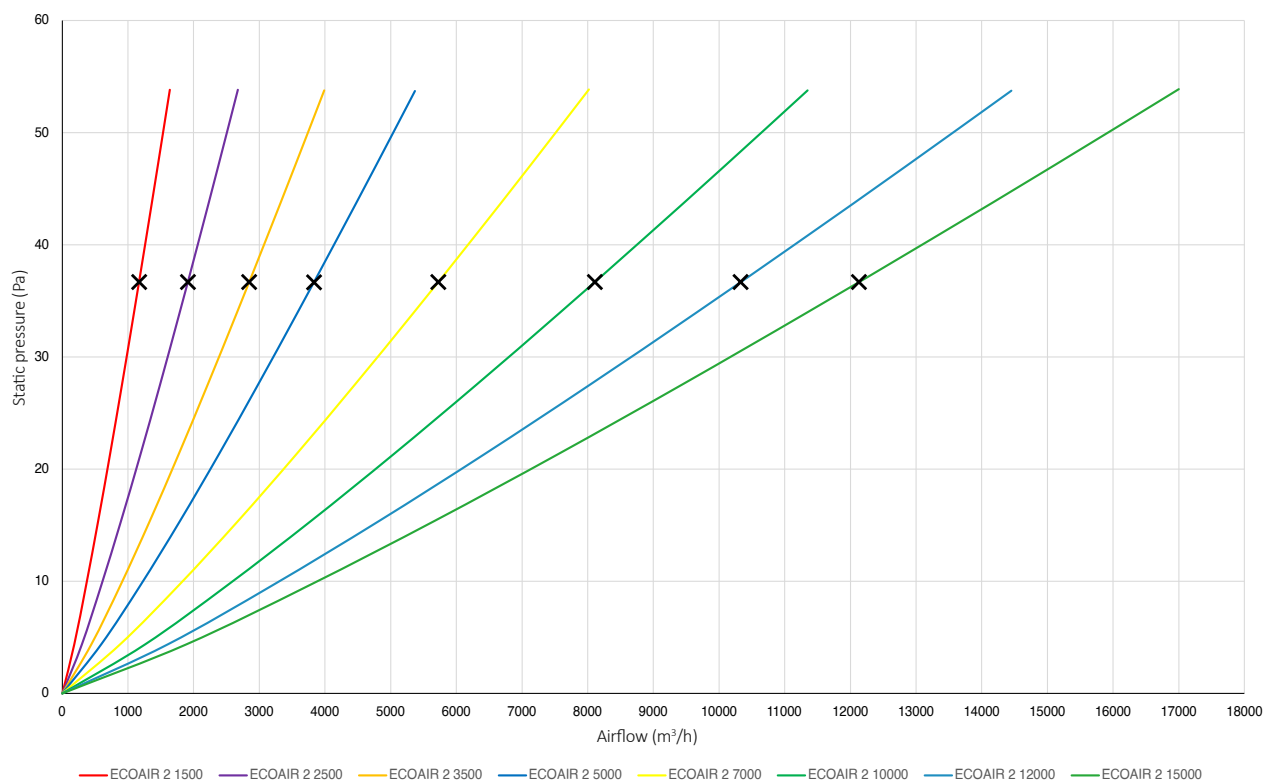
ECOAIR 2 DX COIL MOD

WATER COIL - CHANGE OVER COIL
 DX COIL - DIRECT EXPANSION COIL

DIMENSIONS

ECOAIR 2	1500	2500	3500	5000	7000	10 000	12 000	15 000
A (mm)	550	650	720	810	950	1000	1000	1200
L (mm)	550	650	800	900	1050	1310	1600	1600
P (mm)	1230	1280	1350	1450	1540	1820	1915	1915
Circular cross-section (ØD) (mm)	400	500	560	-	-	-	-	-
Rectangular Cross-Section (CxB) (mm)	-	-	-	750 x 840	890 x 990	940 x 1250	940 x 1540	1140 x 1540
Weight (kg)	22	18	20	32	34	47	55	68

COIL MODULE

ECOAIR 2 - COIL MOD	1500	2500	3500	5000	7000	10 000	12 000	15 000
A (mm)	550	650	720	810	950	1000	1000	1200
L (mm)	550	650	800	900	1050	1310	1600	1600
P (mm)	350	350	350	350	400	400	400	450
Circular cross-section (ØD) (mm)	400	500	560	-	-	-	-	-
Rectangular Cross-Section (CxB) (mm)	-	-	-	750 x 840	890 x 990	940 x 1250	940 x 1540	1140 x 1540

DIMENSIONS

MIXING BOX MODULE

ECOAIR 2 - MIXING BOX	1500	2500	3500	5000	7000	10 000	12 000	15 000
A (mm)	550	650	720	810	950	1000	1000	1200
L (mm)	550	650	800	900	1050	1310	1600	1600
P (mm)	550	650	720	810	950	1000	1000	1200
C/D (mm)	490	590	660	750	890	940	940	1140
E (mm)	490	590	740	840	990	1250	1540	1540
Ak (m ²)	0,39	0,62	0,77	0,63	0,88	1,18	1,45	1,76
v (m/s)	1,11	1,11	1,30	2,12	2,25	2,31	2,37	2,40

A - Height (mm)

C - Length (mm)

Ak - Throat area (m²)

v - Throat velocity (m/s)

DIMENSIONS

NOTE: MAINTENANCE CLEARANCE AND UNIT ACCESS DISTANCE | 750 MM

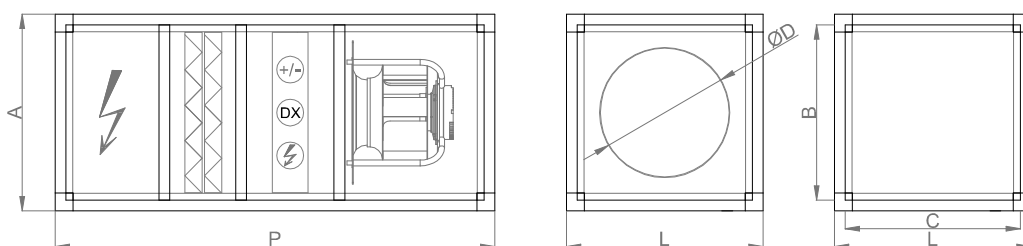

ECOAIR 2
Main Unit

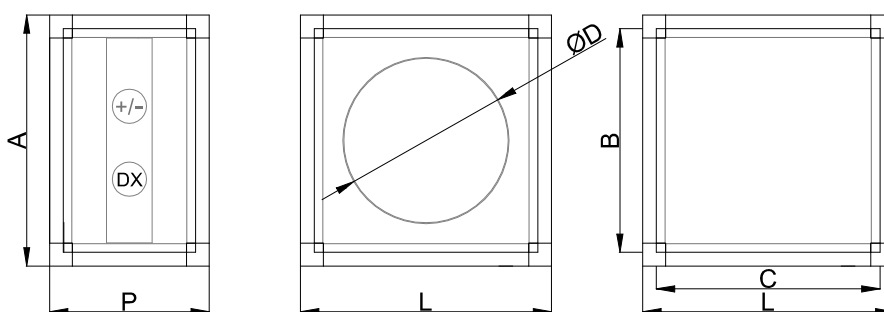

ECOAIR 2
Coil Module

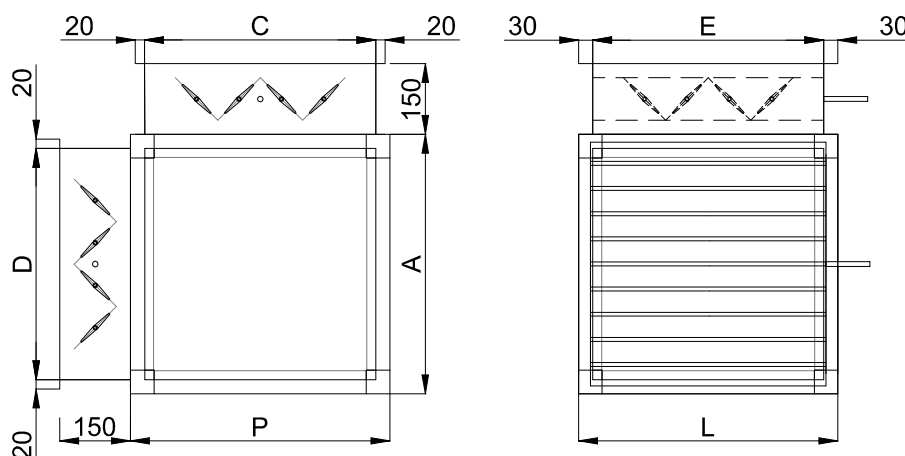

ECOAIR 2
Mixing Box Module

CONFIGURATIONS

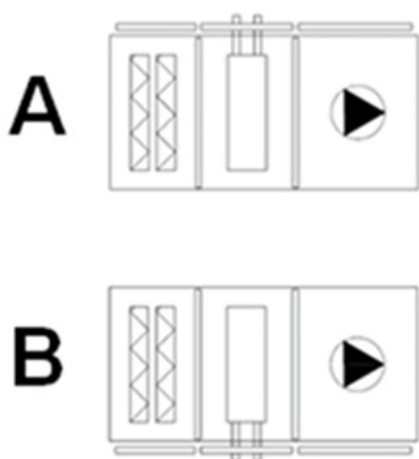

ERP VERIFICATION DOCUMENT

MANUFACTURER		ARFIT AIR CONDITIONING, S.A.							
Model		1500	2500	3500	5000	7000	10000	12000	15000
Type		UVNR UVU							
Transmission Type		Variable Speed	Variable Speed	Variable Speed	Variable Speed	Variable Speed	Variable Speed	Variable Speed	Variable Speed
Heat Recovery System Type		-							
Heat Recovery Thermal Efficiency	%	-	-	-	-	-	-	-	-
Nominal Airflow	m ³ /s	0.4375	0.6667	1.0056	1.3333	1.9792	2.7090	3.4278	3.8889
Input Power	kW	0.712	1.326	1.435	2.583	3.335	3.105	3.637	6.63
SPFint	W/m ³ /s	184.2	203.7	215.7	198.6	207.1	210.9	229.9	228.7
Frontal Velocity	m/s	1.11	1.08	1.30	2.12	2.25	2.31	2.37	2.40
Nominal External Pressure	Pa	674	789	556	884	778	554	506	794
Reduction in Internal Pressure (Ventilation)	Pa	86	90	99	101	109	125	140	123
Static Efficiency of Fans	%	46.7%	44.2%	45.9%	50.9%	52.6%	59.3%	60.9%	53.8%
Maximum Declared Internal/External Leakage Rate	%	-	-	-	-	-	-	-	-
Filter Classification		F7							
Description: Visual notice regarding filters		The filters warning is displayed on the unit's control system, either via a warning light or on-screen message, depending on the control system used. It is of the utmost importance to replace the filters regularly to improve the unit's performance and energy efficiency.							
Sound Power Level (Lwa)	dB(A)	45	49	51	52	54	51	49	59
Website		www.arfit.pt							

A decorative graphic consisting of numerous thin, light green lines that flow and wave across the middle of the page, creating a sense of movement and depth.

your
COMPLETE SOLUTIONS



AIR CONDITIONING UNIT



HIGH EF PLUS

INDEX



Be.On



DC Inverter Compressor and Fan



Wide operating range



High efficiency in heating and cooling



Refrigerant gas

DESCRIPTION

Variable Refrigerant Flow (VRF) R410A condensing unit, INVERTER heat pump system. Composed of an outdoor unit, sensors, and an electronic control board to be integrated into the electrical panel of the Air Handling Unit.

The system can operate in heating mode with a minimum outdoor temperature of -15°C or in cooling mode with a maximum outdoor temperature of 48°C.

The finned coil heat exchanger is equipped with a hydrophobic coating, offering resistance up to 3 times higher than standard, increasing service life. This treatment protects against corrosion caused by water, air, and other corrosive agents.

Compressors and two high-efficiency DC inverter fans ensure maximum efficiency with minimum noise levels.

They allow:

- 30% reduction in energy consumption.
- 70% reduction in compressor size.
- 50% reduction in weight.

ADVANTAGES

- Silent monobloc Plug & Play units.
- Low energy consumption with variable refrigerant volume system.
- Easy integration with Arfit Air Handling Units and heat recovery units.
- Condensing unit monitoring via AHU control system.
- Possibility of integrating Be.On module with direct cloud connection and Be.Smart monitoring.

CHARACTERISTICS

HIGH EF PLUS		8 10 14			20 26 40		
Power Supply eléctrica	(V F Hz)	220 - 240 1 50			380 - 415 3 50		
Cooling capacity ¹	(kW)	8	9	14	20	26	40
	(W)	2100	2640	3970	5280	10040	15700
	EER (W/W)	3,81	3,41	3,53	3,79	2,59	2,54
Heating capacity ²	(kW)	9	9	16	20	26	40
	(W)	2040	2100	3980	4430	6860	11700
	COP (W/W)	4,41	4,29	4,02	4,51	3,79	3,42
Airflow	m ³ /h	3750	5200	5200	9000	10000	12500
Sound Pressure	dB (A)	54	54	56	58	59	59
Room temperature	Cooling °C	-15~55	-15~55	-15~55	-5 ~ 48		-15 ~ 55
	Cooling °C		-15 ~ 27		-20 ~ 24		-30 ~ 30
Refrigerant gas (Pre-charge)	Type	R410A					
	kg	1,7	2,35	3,1	6,5		7,4

Notes:

- 1 - Indoor air temperature 27°C DB, 19°C WB; outdoor air temperature 35°C DB; equivalent refrigerant piping length 7.5 m with zero level difference.
- 2 - Indoor air temperature 20°C DB; outdoor air temperature 7°C DB, 6°C WB; equivalent refrigerant piping length 7.5 m with zero level difference.
- 3 - Sound pressure level measured at 1 m in front of the unit and 1.3 m above ground in a semi-anechoic chamber.

DIMENSIONS

HIGH EF PLUS		8	10	14	20	26	40
Dimension	L X A X P (mm)	910x712x426	950x840x426	950x840x440	1.120x1.558x528		1130x1760x580
Weight (kg)		49	72,5	75	143	144	187
Connection cables	Electrical power supply (mm ²)	3X4	3X4	3X6	4X4+T	4X6+T	4X6+T
	Communication (mm ²)	3X1	3X1	3X1	3X1	3X1	3X1
Piping	Liquid line (mm)	9,53	9,53	9,53	12,7	12,7	12,7 - 1/2"
	Gas line (mm)	15,9	15,9	15,9	19,1	22,2	25,4 - 1"
Distances	Vertical (m) - Outdoor unit above	10	20	30	50	50	50
	Vertical (m) - Outdoor unit below	10	20	20	40	40	40
	Total (m)	35	45	70	90	90	90

ARFIT CONDENSING UNITS WITH DX CONDENSER CONNECTION KIT

HIGH EF PLUS		8	10	14	20	26	40
Condensing unit connections	Gas diameter (mm)	15,9 (5/8")	15,9 (5/8")	15,9 (5/8")	19,1 (3/4")	22,2 (7/8")	25,4 (1")
	Liquid diameter (mm)	9,53 (3/8")	9,53 (3/8")	9,53 (3/8")	12,7 (1/2")	12,7 (1/2")	12,7 (1/2")
Size Kit		BB001	BB002	BB002	BB002	BB003	BB004
DX kit	Gas diameter (mm)	(E) 9,53 (3/8")	(E) 9,53 (1/2")	(E) 9,53 (1/2")	12,7 (5/8")	12,7 (5/8")	12,7 (5/8")
	Liquid diameter (mm)	(F) 9,53 (3/8")	(F) 12,7 (1/2")	(F) 12,7 (1/2")	(F) 12,7 (5/8")	(F) 12,7 (5/8")	(F) 15,9 (5/8")
Connection cable between kit and condensing unit		Cable Olflex 3x1,5mm ²					
AHU coil	Gas diameter (mm)	(B)	(B)	(B)	(B)	(B)	(B)
	Liquid diameter (mm)	(B)	(B)	(B)	(B)	(B)	(B)

Caption:

A - Notify support 15 days before start-up of the distance between AHU and condensing unit and request commissioning if necessary.

B - Refer to final AHU drawing for approval.

C - For sizing of connection cables to AHU and condenser, refer to AHU technical sheet and condenser catalogue. Power supplies are individual from HVAC electrical panel.

D - Support email: suporte@arfit.pt

E - DX kit is factory supplied with 8 mm - 5/16" inlet and outlet pipes.

F - DX kit is factory supplied with 12.7 mm - 1/2" inlet and outlet pipes.

- During installation of the refrigeration circuit, always respect inlet and outlet directions on the control box (DX kit) and AHU coil.

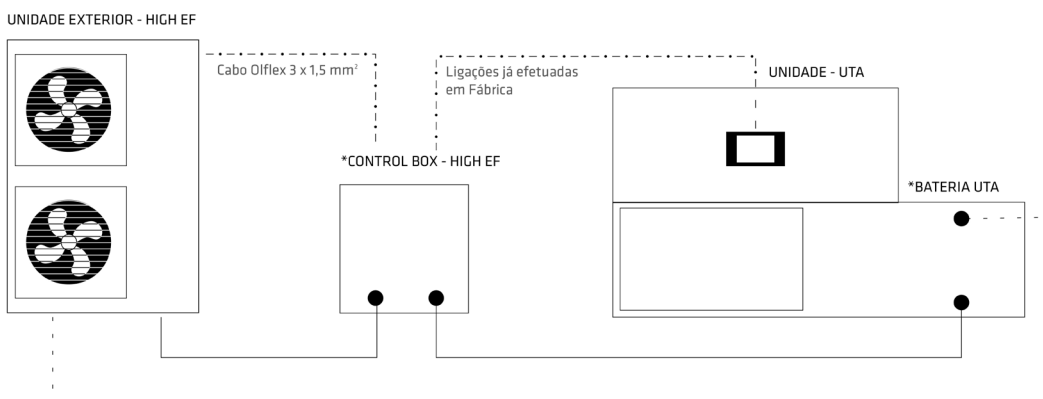

Legenda:

- - - - - Ligações elétricas
- Tubagem de líquido
- - - - - Tubagem de gás

* When installing the refrigeration circuit, always follow the inlet and outlet specifications on the control box (DX kit) and the AHU coil

A decorative graphic consisting of multiple thin, light green wavy lines that create a sense of motion and depth across the middle of the page.

your
COMPLETE SOLUTIONS







CONTROL







A control system plays a fundamental role in creating comfortable, healthy, efficient, and sustainable indoor environments in commercial, residential, and institutional buildings.



CONTROL TABLE

					
		CM3D	CM2D	CM4B	SMART SMART CO2
Fan coil units and low-profile units*		●			
Residential heat recovery	VMC			●	
	VMC 2		●		
Industrial heat recovery	ECOevo 2 EC				●
	ECOevo 2 AC				●
	ECOevo 3 SLIM				●
	ECOevo 3				●

*Attention: CM3D accessory

						
		SMART EVOLUTION	SMART PRO 2	SMART VISION 5	SMART SERVER	SMART EYES
Industrial heat recovery	ECOevo 2 EC	●				
	ECOevo 3 SLIM	●				
	ECOevo 3	●				
	ECOevo 2 PLUS	●				
Air Conditioning	ECOAIR 2 SLIM	●				
	ECOAIR 2	●				
Air Treatment	PURE P	●	●			
	PURE H	●	●			
BMS Solutions				●	●	●

THERMAL COMFORT

Precise indoor temperature control helps ensure occupant comfort throughout all seasons of the year. This is essential for the well-being and productivity of people working or living in the building.

INDOOR AIR QUALITY

Proper ventilation and effective air filtration ensure that indoor air remains clean and healthy to breathe.

ENERGY EFFICIENCY

A well-designed control system can significantly reduce building energy consumption. This can be achieved through the use of efficient technologies such as zoning systems, energy recovery, variable speed control, and optimized operating cycle management.

REDUCED OPERATING COSTS

The energy efficiency resulting from a proper HVAC control system can lead to lower operating costs for the building, generating long-term savings.

SUSTAINABILITY

Reducing energy consumption and minimizing the environmental impact associated with HVAC system operation contributes to making the building more sustainable and aligned with green building practices.



CM3D

INDEX



DESCRIPTION

Controller for terminal units, CM3D model, with backlit LCD digital display, allowing management of the units through various available functions to optimize operation. Optional Wi-Fi connection or ModBus communication protocol (RS485) for even easier operation.



Wi-Fi



Display



Mod Bus

ADVANTAGES

- Elegant and compact design.
- Multiple functions.

ACCESSORIES

- Relay board

CHARACTERISTICS

CM3D	PR EC	PR AC	BR EC	BR AC
Voltage (V / Hz)	230 V / 50 Hz	230 V / 50 Hz	230 V / 50 Hz	230 V / 50 Hz
Maximum current (A)	3A	3A	3A	3A
Operating range (°C)	5°C a 35°C	5°C a 35°C	5°C a 35°C	5°C a 35°C
Output	On - Off	On - Off	On - Off	On - Off
Display temperature (°C)	0 a 70°C	0 a 70°C	0 a 70°C	0 a 70°C
Ambient temperature (°C)	-10°C a 60°C	-10°C a 60°C	-10°C a 60°C	-10°C a 60°C

DIMENSIONS

CM3D	PR EC	PR AC	BR EC	BR AC
A (mm)	86	86	86	86
B (mm)	16	16	16	16
C (mm)	32	32	32	32
D (mm)	48	48	48	48

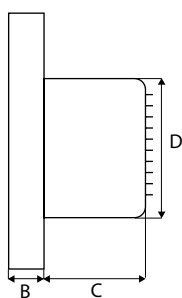
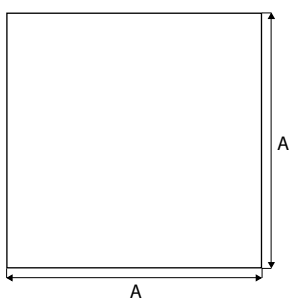

FEATURES

CM3D	CM3D PR EC	CM3D PR AC	CM3D BR EC	CM3D BR AC
Digital display	●	●	●	●
Time scheduling	●	●	●	●
Summer / Winter / Ventilation / Auto mode	●	●	●	●
3-speed ventilation / Auto - AC		●		●
3-speed ventilation / Auto - EC	●		●	
Temperature alarm	●	●	●	●
Heating valve control On-Off	●	●	●	●
Cooling valve control On-Off	●	●	●	●
Sleep Mode	●	●	●	●
Safety lock	●	●	●	●
ModBus (RS485)	●	●	●	●
Wi-Fi control	●	●	●	●
Black panel	●	●		
White panel			●	●

- Standard

NOTE: Functions applied according to the unit.



CM2D

INDEX



Plug & Play



Display

DESCRIPTION

Wireless control system for quick and easy installation. Optional additional controls also allow humidity and CO₂ monitoring of the conditioned space. Through the CMAPP module, it is possible to view indoor and outdoor temperatures and adjust fan speeds as required. To use this module, an internet connection with Wi-Fi router is required. Through the CMMODBUS module, the unit can also be connected to a Building Management System (BMS).

An advantageous solution to make residential spaces more efficient through a fully autonomous and intelligent system.

ADVANTAGES

- Easy operation.
- Plug & Play.
- Simple and elegant.

ACCESSORIES

- Humidity sensor
- CO₂ sensor
- Wi-Fi kit

FEATURES

CHARACTERISTICS	CM2D	CM2CH	CM2CO ₂	CM2WIFI
Speed control	●	●	●	●
By-pass*	●	●	●	●
Protection	●	●	●	●
Filter clogging indication	●	●	●	●
ModBus gateway (R485)	●	●	●	●
Settings	●	●	●	●
On-Off	●	●	●	●
Alarms	●	●	●	●
Sleep mode	●	●	●	●
Time scheduling	●	●	●	●
Humidity control		●		○
CO ₂ control			●	○
Wi-Fi control				●

* Except for VMC2 150H model

Caption:

- Wi-Fi controller compatible with optional humidity and CO₂ monitoring controller
- Standard

CM4B

[INDEX](#)

Plug & Play



Controller

DESCRIPTION

Wireless control system for quick and easy installation. Optional additional controls also allow humidity and CO₂ monitoring of the conditioned space. Through the CMAPP module, it is possible to view indoor and outdoor temperatures and adjust fan speeds as required. To use this module, an internet connection with Wi-Fi router is required. Through the CMMODBUS module, the unit can also be connected to a Building Management System (BMS).

An advantageous solution to make residential spaces more efficient through a fully autonomous and intelligent system.

ADVANTAGES

- Easy operation.
- Plug & Play.
- Simple and elegant.

ACCESSORIES

- Humidity sensor
- CO₂ sensor
- Modbus
- App
- Digital display

FEATURES

CHARACTERISTICS	CM4B	CMCH	CMCO ₂	CMMODBUS	CMAPP	CMDISP
Speed control	•	•	•		•	•
By-pass	•	•	•		•	•
Protection	•	•	•		•	•
Filter clogging indication	•	•	•		•	•
Humidity control		•				
CO ₂ control			•			
Booster function	•				•	•
ModBus gateway				•	•	
Settings						•
On - Off						•
Alarms	•	•	•			•



Plug & Play



Display

DESCRIPTION

The Smart control system allows complete management and monitoring of the product operation with all its functionalities and accessories, such as free-cooling/free-heating management, fixed or variable speed fans, filter status monitoring, time scheduling, and indoor air quality control.

Its elegant display allows simple and intuitive visualization and control of unit operation. Available in Smart and Smart CO₂ versions.

ADVANTAGES

- Plug & Play units with included field equipment.
- ModBUS RTU communication protocol.
- Daily and weekly scheduling.
- Remote display possibility.
- Optional CO₂ control version.

FUNCTIONS

DDC controller with integrated digital display for installation on the unit or remotely - communication through standard protocol (ModBUS RTU/ASCII). IP65 electrical panel mounted on the unit, equipped with external main isolator switch. All field equipment required for correct unit operation is included.

REMOTE INSTALLATION



FEATURES

CHARACTERISTICS	SMART	SMART CO ₂
Plug & Play control system	●	●
Electrical panel with all protections	●	●
Main isolator switch	●	●
Fully installed field equipment	●	●
On-Off Remote	○	○
Summer / Winter changeover Remote	○	○
ModBus-RTU interface for BMS connection	●	●
Operating modes: Economy / Night / Day	○	○
Last maintenance date record	○	○
Alarm history	○	○
Operating hours monitoring per component	○	○
Heat recovery defrost system	○	○
CO ₂ control through ambient sensor on display	○	●
Integrated web server	○	○
BYPASS	SMART	SMART CO ₂
Bypass control with 2 temperature sensors and servomotor	●	●
Free Cooling set point	●	●
Free Heating set point	○	○
Automatic Summer / Winter changeover	○	○
DISPLAY	SMART	SMART CO ₂
Fresh air temperature display	●	●
Extract air temperature display	●	●
Supply / Return fan airflow adjustment	●	●
Supply fan airflow adjustment	○	○
Return fan airflow adjustment	○	○
Clogged filter indication	●	●
Fan failure indication	○	○
Daily and weekly scheduling	●	●
Controller with integrated digital display for control and visualization of all parameters and alarms	○	○
Digital interface	●	●
Backlit display	●	●

Caption:

- Standard
- Available only in Smart Evolution version

NOTE: Functions applied according to the unit.



SMART EVOLUTION

INDEX

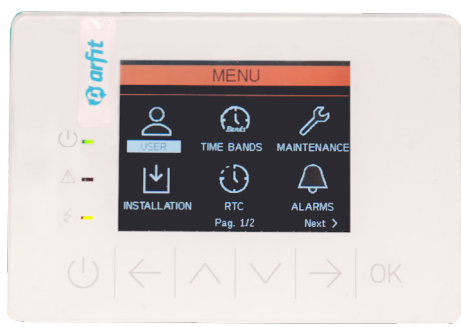

Plug & Play



Display

ADVANTAGES

- Plug & Play units with included field equipment.
- ModBUS RTU communication protocol.
- Operating hours record per component and alarm history.
- Daily and weekly scheduling.
- Remote display possibility.
- Optional control for water coil or electric heating coil, constant airflow regulation, or CO₂ control.

FUNCTIONS

DDC controller with remote digital display and communication through standard protocol (ModBUS RTU/ASCII). IP65 electrical panel mounted on the unit, equipped with external main isolator switch. All field equipment required for correct unit operation is included.

DESCRIPTION

The SMART EVOLUTION control system allows complete management and monitoring of product operation with all functionalities and accessories, such as free-cooling/free-heating management, fixed or variable speed fans, water heating or cooling coil control, electric heating coil control, filter clogging monitoring, time scheduling, constant airflow control, and indoor air quality control.

Its elegant display allows simple and intuitive visualization and control of unit operation.

REMOTE INSTALLATION

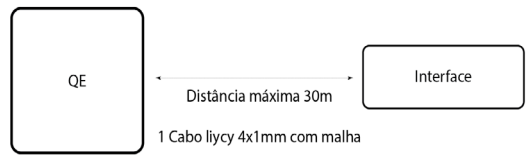

FEATURES

CHARACTERISTICS	SMART EVOLUTION
Plug & Play control system	●
Electrical panel with all protections	●
Main isolator switch	●
Fully installed field equipment	●
On-Off Remote	●
Summer / Winter changeover Remote	●
ModBus-RTU interface for BMS connection	●
Operating modes: Economy / Night / Day	●
Last maintenance date record	●
Alarm history	●
Operating hours monitoring per component	●
Heat recovery defrost system	●
BYPASS*	SMART EVOLUTION
Bypass control with 2 temperature sensors and servomotor	Standard ECOAIR/ ECDEVO EC/ ECDEVO PLUS*
Fresh air temperature display	Standard PURE*
Free Cooling set point	●
Free Heating set point	●
Automatic Summer / Winter changeover	●
DISPLAY	SMART EVOLUTION
Fresh air temperature display	●
Extract air temperature display	●
Supply fan airflow adjustment /Retorno	●
Supply fan airflow adjustment	○
Return fan airflow adjustment	○
Clogged filter indication	○
Fan failure indication	●
Daily and weekly scheduling	●
Controller with integrated digital display for control and visualization of all parameters and alarms	SMART PRO
Digital interface	●
Backlit display	●
CONTROL*	SMART EVOLUTION
Air conditioning temperature control by sensor and modulating 3-way valve	Standard PURE* Opcional ECOAIR/ ECDEVO EC/ ECDEVO PLUS*
Heating temperature control by sensor and modulating 3-way valve	Standard PURE* Opcional ECOAIR/ ECDEVO EC/ ECDEVO PLUS*
Electric heating temperature control by staged electric heaters	Standard PURE* Opcional ECOAIR/ ECDEVO EC/ ECDEVO PLUS*
Fan delay for post-ventilation	Standard PURE* Opcional ECOAIR/ ECDEVO EC/ ECDEVO PLUS*
Cooling temperature control by sensor and condenser control system	Standard PURE* Não disponível ECOAIR/ ECDEVO EC/ ECDEVO PLUS*
Constant airflow	○
CO ₂ control by ambient sensor	○

● Standard

○ Optional

* According to each unit configuration

NOTE: Functions applied according to the unit.



SMART PRO 2

[INDEX](#)

Plug & Play



Display

ADVANTAGES

- Plug & Play units with included field equipment.
- ModBUS RTU communication protocol, controller with digital display and integrated web server.
- Operating hours record per component and alarm history.
- Daily and weekly scheduling.
- Remote display possibility.
- Constant airflow or CO₂ based control.

FUNCTIONS

DDC controller with integrated display, communication via standard protocol (ModBUS RTU/IP, BACNET IP), and integrated web server.

IP65 electrical panel mounted on the unit, equipped with external main isolator switch. All field equipment required for proper unit operation is included.

DESCRIPTION

The SMART PRO 2 control system allows complete management and monitoring of product operation with all its functionalities and accessories, such as free-cooling/free-heating management, fixed or variable speed fans, control of water heating or cooling coils and electric heating coils, filter clogging monitoring, time scheduling, as well as constant airflow control or indoor air quality control.

Optional elegant display design allows simple and intuitive visualization and control of unit operation.

REMOTE INSTALLATION



FEATURES

CHARACTERISTICS	SMART PRO 2
Plug & Play control system	●
Electrical panel with all protections	●
Main isolator switch	●
Fully installed field equipment	●
On-Off Remote	●
Summer / Winter changeover Remote	●
ModBus-RTU interface for BMS connection	●
Operating modes: Economy / Night / Day	●
Last maintenance date record	●
Alarm history	●
Operating hours monitoring per component	●
Heat recovery defrost system	●
Integrated web server	●
BYPASS*	SMART PRO 2
Fresh air temperature display	●
Free Cooling set point	●
Free Heating set point	●
Automatic Summer / Winter changeover	●
DISPLAY	SMART PRO 2
Fresh air temperature display	●
Extract air temperature display	●
Supply fan airflow adjustment	●
Return fan airflow adjustment	●
Clogged filter indication	●
Fan failure indication	●
Daily and weekly scheduling	●
Controller with integrated digital display for control and visualization of all parameters and alarms	●
Backlit display	●
Display remoto LED 4"	○
CONTROL*	SMART PRO 2
Air conditioning temperature control by sensor and modulating 3-way valve	●
Heating temperature control by sensor and modulating 3-way valve	●
Electric heating temperature control by staged electric heaters	●
Fan delay for post-ventilation	●
Cooling temperature control by sensor and condenser control system	●
Constant airflow	○
CO ₂ control by ambient sensor	○

● Standard

○ Optional

* According to each unit configuration

NOTE: Functions applied according to the unit.



SMART VISION 5

[INDEX](#)

Plug & Play



Display

ADVANTAGES

- Possibility of supplying a complete Plug & Play solution with factory-mounted electrical panel.
- Customized interface on the server where the software is installed.
- WEBVISION 5 dashboard with flexible use through graphical editor.
- Installation KPI calculation.

FUNCTIONS

Centralization, in at least one human-machine interface, of operational capability through dynamic synoptics, operation optimization, alarm management, event management, and historical archive with report generation capability. Communication capability between technical systems and other equipment through standardized protocols (Modbus, BACnet, DALI, KNX, M-Bus, etc.). Capability to perform electrical energy metering by system or HVAC installation; general metering for lighting systems; general metering of electrical energy, thermal energy, and other building energy sources.

Capability to maintain historical data archives, exportable to spreadsheets and common file formats, for the last 6 years of the following variables with a minimum 15-minute interval; outdoor air temperature and humidity; average indoor air temperature, or temperature of each individually controlled zone; Electric motor operating times; CO₂ measurement, when applicable; water outlet temperature from cooling and heating generating equipment.

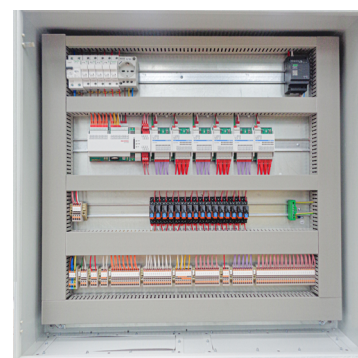

DESCRIPTION

Control solution for Building Management Systems, SMARTVISION model, composed of:

Management server and software accessible via mobile devices, tablets, or desktops. Communication infrastructure with equipment enabling interconnection between management stations and system controllers. Data storage capacity of up to 6 years with 15-minute interval records.

DDC controllers with BACnet Building Controller B-BC certification and compliant with VDI3814 (DIN EN ISO 16484). Integrated graphical web server accessible via mobile phone or desktop. 16 GB SD card for storing up to 1,000 trend log objects with 64,000 records each.

Onboard interfaces: 0-10 V 10 Bit analog outputs, 230 V AC / 6A relays, universal inputs, digital inputs, RS485 for Modbus RTU master or BACnet MS/TP communication.

45 expansion modules available for a complete BMS system, including ModBus master/slave gateways, M-Bus, DALI, KNX, EnOcean, MPBUS, SMI, etc.

CHARACTERISTICS

- Centralized control system with Building Management Software.
- Solution for installations with thermal capacity >290 kW.
- Possibility of supply with factory-mounted electrical panel (EP).
- BACnet Building Controller B-BC rev.1.15 certified controller.
- Unlimited integration of variables per equipment.
- User access profile configuration.
- Server with historical data storage capacity up to 6 years.

SMART SERVER

INDEX



Plug & Play



Display

DESCRIPTION

Control solution for Building Management Systems, SMARTSERVER model, composed of:

DDC controllers with BACnet Building Controller B-BC certification and compliant with VDI3814 (DIN EN ISO 16484).

Integrated graphical web server accessible via mobile phone or desktop.

Onboard interfaces: 0-10 V 10 Bit analog outputs, 230 V AC / 6A relays, universal inputs, digital inputs, RS485 for Modbus RTU master or BACnet MS/TP communication.

45 expansion modules available for a complete BMS system, including ModBus master/slave gateways, M-Bus, DALI, KNX, EnOcean, MPBUS, SMI, etc.

ADVANTAGES

- Possibility of supplying a complete Plug & Play solution with factory-mounted electrical panel.
- Customized interface within the controller through integrated graphical web server.
- Remote access via Supervisory Workstation, Remote Display, or Mobile Phone.
- 16 GB SD card allowing storage of:
 - up to 1,000 trend log objects.
 - up to 64,000 records per object.

CHARACTERISTICS

- Centralized control system with integrated graphical web server.
- Remote access via Supervisory Workstation, display, or mobile phone.
- Solution for installations with thermal capacity < 290 kW.
- Possibility of supply with factory-mounted electrical panel (EP).
- BACnet Building Controller B-BC rev.1.15 certified controller.

FUNCTIONS

Centralization, in at least one human-machine interface, of operation through synoptic dia-grams, installation operation management, alarm management, and event management. Communication capability between technical systems and other equipment through standardi-zed protocols (Modbus, BACnet, DALI, KNX, M-Bus, etc.). Capability to perform electrical energy metering by system or HVAC installation.

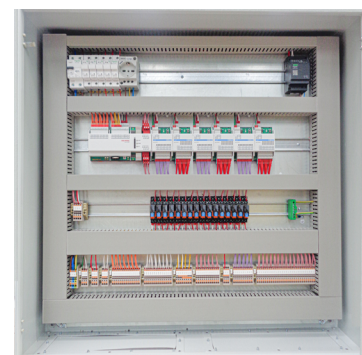



SMART EYES

[INDEX](#)

Plug & Play



Display

ADVANTAGES

- Plug & Play units supplied with outdoor temperature and humidity sensor included.
- Features ModBUS RTU communication protocol, controller with touchscreen display, and integrated web server.
- Operating hours recording per component and alarm history.
- Daily and weekly scheduling.
- Possibility of remote display.
- Composed of a DDC controller, expansion modules, and a 7" remote touchscreen display.

FUNCTIONS

SMART EYES control management solution designed to control, monitor, and manage HVAC installations. The display allows the operator to centrally monitor and control all equipment through interactive menus. Through the integrated web server, the system enables remote access for operation and monitoring of the entire installation. The DDC controller is supplied factory-mounted and pre-wired inside a dedicated electrical panel for simple and fast Plug & Play installation.

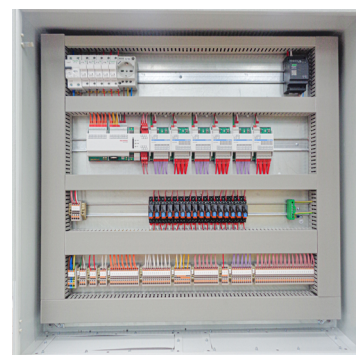



DESCRIPTION

Arfit Solution for centralized control in HVAC systems. Supplied in a factory-wired electrical panel, ensuring simple and fast installation. Local access via touchscreen display or remote access through integrated web server. Energy metering capability available. System commissioning shall be carried out by a specialized Arfit technician, who may also provide remote assistance services.

Available in 3 versions – Light, Medium, and Premium – for installations of different sizes and number of units to be controlled.

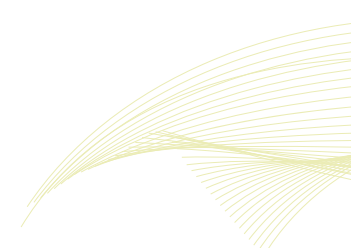
- ARFIT Centralized Control System for installations with thermal capacity < 290 kW.
- BACnet laboratory-certified controller.
- Possibility of configuring 3 levels of controller access.





your
COMPLETE SOLUTIONS



ACCESSORIES



ACCESSORIES FOR PRODUCT RANGE

[INDEX](#)

PROTECTION FOR RAIN (INTAKE OR EXHAUST)

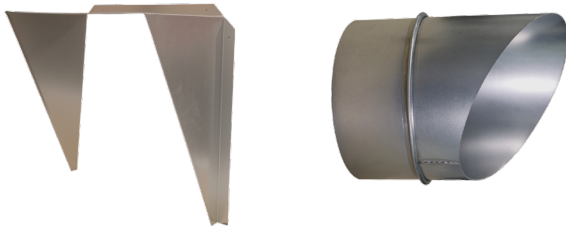

Manufactured in epoxy polyester painted sheet metal, with protective mesh. Supplied as a kit.

RAIN ROOF



Made of epoxy polyester painted sheet metal, installed on top of the unit. Supplied as a kit.

ISOLATION SWITCH



Provides main power disconnection for the unit. Suitable for outdoor installation, IP65.

ON / OFF SWITCH



On-Off switch for single-phase fans, housed in white ABS enclosure, for indoor installation, IP20.



VOLTAGE CONTROLLER



Allows airflow modulation of the unit by varying supply voltage. Includes minimum speed adjustment. For indoor installation IP20 (models up to 3A) and outdoor installation IP54 for remaining models.

FREQUENCY INVERTER



Allows airflow modulation of the unit by varying supply frequency. Enables minimum speed adjustment, remote On-Off, and 3-speed operation. For indoor installation IP20.

SPEED SELECTOR



Allows selection and switching of electric motor speeds with multiple speed options. Surface or flush mounting with IP54 and IP44 protection ratings.

CONSTANT AIRFLOW CONTROL



System for controlling airflow or system pressure by measuring operating pressure to regulate fan speed.



CO₂ CONTROL

Control of CO₂ level in the installation via a sensor placed in the unit return air. Fan speed modulation according to CO₂ levels.



0-10 V AIRFLOW CONTROLLER

Allows airflow modulation of EC motors via a 0-10 V control signal to the electronic board. For indoor installation IP20.



AIR PRESSURE SWITCH

Air pressure switch used for fan operation indication or filter clogging monitoring.



FILTERS

The base unit price does not include filters. One or two filters must be added depending on the required filtration class for the supply airflow and return airflow.

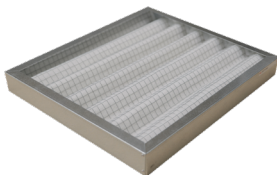

VMC / VMC2 INSTALLATION ACCESSORIES

INDEX

ANTIBACTERIAL FLEXIBLE DUCT TF75 AND TF90



High-strength, highly flexible air distribution duct, anti-static and antibacterial. Outer wall made of HDPE (High-Density Polyethylene). Halogen-free. Treated against fungi and bacteria. Supplied in 50 m rolls.

DIMENSIONS

TF	ø 75	ø 90
Outer diameter (mm)	75 (+1,5)	90 (+ 1,5)
Inner diameter (mm)	63 (± 1)	73 (± 1)
Mean bending radius (mm)	270	330
Roll length (m)	50	50
Roll dimensions (mm)	360x1170x1170	400x1200x1200
Weight (kg)	15	21

TF160 FLEXIBLE DUCT



Flexible PVC duct Ø160, insulated with a 25 mm polyester layer. Supplied in 10 m rolls. Used to connect units to distribution plenums.

DIMENSIONS

TF	ø160
Outer diameter (mm)	160
Wall thickness (mm)	25
Roll length (m)	10

DISTRIBUTION PLENUM PLDTC4, PLDTC6 AND PLDTC10



Multidirectional distribution plenum manufactured in galvanized steel with internal acoustic insulation. Available with 4, 6 or 10 connections for Ø75 or Ø90 mm duct, sealed with rubber gaskets. Each connection includes an airflow balancing damper with external adjustment knob. Opposite side connects to Ø160 mm duct. Possibility to change connection orientation (top/front) on site. 4- and 6-connection models supplied with 2 blanking caps. 10-connection model supplied with 3 blanking caps.

DIMENSIONS

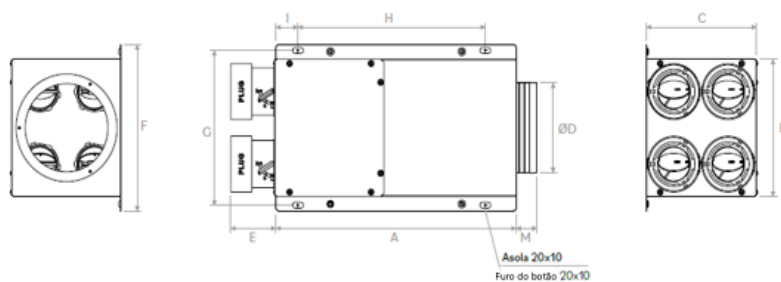
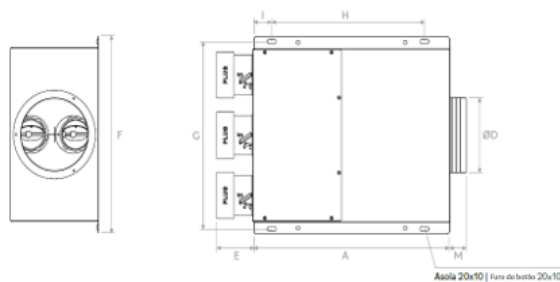
PLDTC	4	6	10
A (mm)	442	442	442
B (mm)	237	362	624
C (mm)	202	202	202
øD (mm)	156	156	156
E (mm)	83,5	83,5	83,5
F (mm)	287	412	674
G (mm)	267	392	654
H (mm)	345	345	345
I (mm)	40	40	345
M (mm)	38	38	38

4 CONNECTIONS

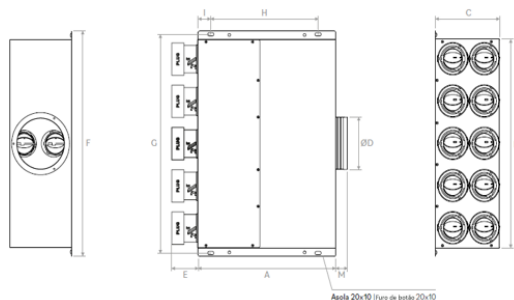
6 CONNECTIONS

10 CONNECTIONS

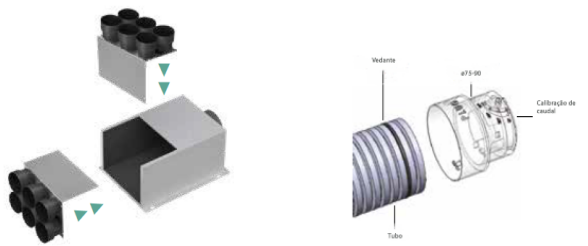

CONSTRUCTION DETAILS



AIR DISTRIBUTION PLENUM PLDTA

Air distribution plenum in black painted steel for wall installation, with plastic connectors. Compatible with Ø75 or Ø90 mm duct connections. Each connection includes airflow regulator. Connection orientation can be changed on site between top and rear positions.



DIMENSIONS

PLDTA	200X100	250X100	350X150
A (mm)	100	100	100
B (mm)	197	247	347
C (mm)	225	275	375
D (mm)	125	125	175
E (mm)	82	82	82
F (mm)	-	25	-
G (mm)	-	120	120
H (mm)	98	98	148

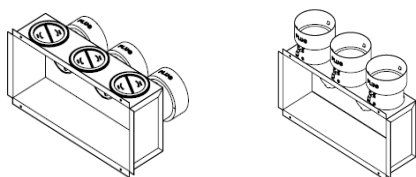

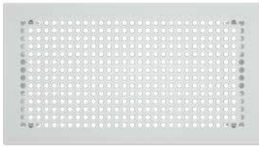
PERFORATED SUPPLY GRILLE GPI

Perforated grille for supply/return air. Steel construction with RAL 9003 finish.

DIMENSIONS

GPI	200X100	250X100	350X150
A (mm)	85	85	135
B (mm)	191	241	341
C (mm)	230	280	380
D (mm)	130	130	180
E (mm)	8	8	8
F (mm)	41	41	41

SUPPLY GRILLE GLI

Supply/return grille in aluminium with RAL 9003 finish.

DIMENSIONS

GLI	200X100	250X100	350X150
A (mm)	85	85	135
B (mm)	191	241	341
C (mm)	230	280	380
D (mm)	130	130	180
E (mm)	8	8	8
F (mm)	41	41	41

EXTRACTION VALVE VAM E165



Ø125 mm steel valve with RAL 9010 finish. Supplied with mounting ring.

DIMENSIONS

VAM	E165
ø A (mm)	165
B (mm)	104
C (mm)	50
D (mm)	123
E (mm)	50

90° ELBOW C90P



90° plastic elbow for connection to Ø125 mm valves. Connection for Ø90 mm duct.

DIMENSIONS

C90P	ø125
ø A (mm)	125
ø B (mm)	92
C (mm)	196
D (mm)	360

ELBOW JOINTS JP9075 AND JP9090

90° plastic elbow for Ø90-Ø90 mm duct connection. 90° plastic elbow for Ø75-Ø90 mm duct connection.

DIMENSIONS

JP	9075	9090
ø A (mm)	75	92
ø B (mm)	103	117
C (mm)	128	147

90° CURVE C902P

90° plastic connection curve.

DIMENSIONS

C902P	75	90
A (mm)	94	123
B (mm)	125	125
ø C (mm)	75	92
D (mm)	330	361

ROUND EXTERNAL GRILLE GCA181



External grille for fresh air/exhaust, with mesh. Aluminium construction with RAL 9003 finish.

DIMENSIONS

GCA	181
ø D (mm)	181
ø D (mm)	159
H (mm)	18
S (mm)	3

AIR INTAKE GRILLE WITH MESH GE



External air grille with fixed horizontal blades at 45° pitch, 25 mm spacing, anti-rain profile and bird protection mesh. Aluminium construction with RAL 9003 finish. Suitable for airflows above 350 m³/h.

DIMENSIONS

GE	400X200
A (mm)	431
B (mm)	200
C (mm)	45
H (mm)	400
D (mm)	231

your
COMPLETE SOLUTIONS



ADRESS

Zona Industrial da Maia I, Sector VIII
R. de Carlos Sousa Gomes 390,
4475-130 Gemunde, Maia - Portugal

