

Tetris W Rev OH TB

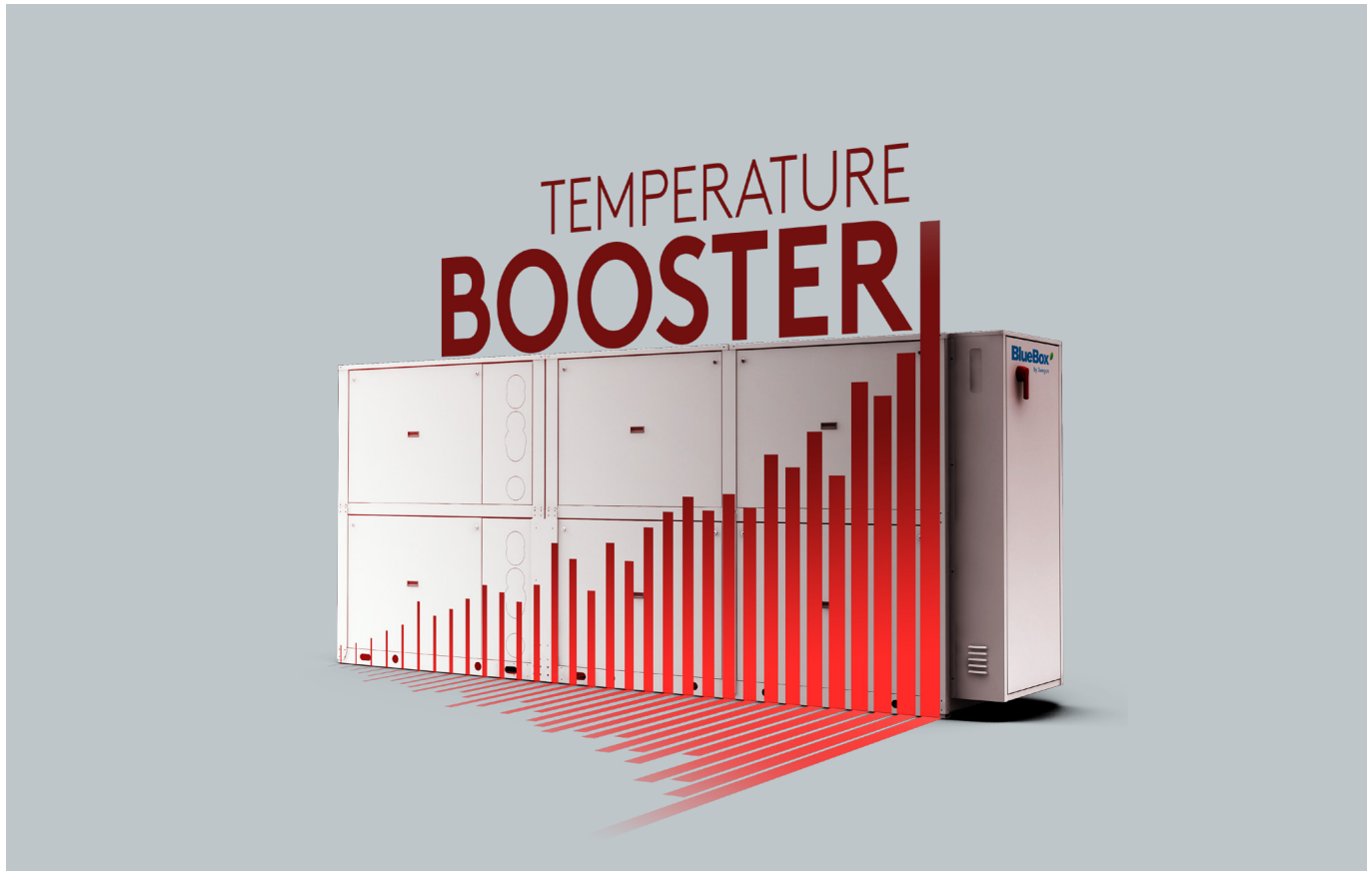

70÷530 kW



General

Non-reversible water heat pump with scroll compressors optimized for high temperature applications. Solution designed to reach very high temperature levels.

Configurations

OH: non-reversible heat pump standard

/LN: low-noise unit

MOIB: execution for additional hydraulic module

Strengths

- ▶ Production of hot water up to 80 ° C
- ▶ Alternative solution to traditional heating systems
- ▶ New business opportunities, flexibility and the creation of cascaded systems
- ▶ Wide operating range, extended operating limits
- ▶ BlueThink advanced control with integrated web server. Multilogic function and Blueeye® supervision system. (options)
- ▶ Flowzer: inverter driven pumps (options)

BlueBox 
by Swegon

Tetris W Rev OH TB

One machine, many solutions, new business opportunities	3
Options	5
Hydraulic circuit accessories	6
Refrigerant circuit accessories	9
Electrical accessories	10
Network accessories	14
Other accessories	17
Technical specifications	19
Ecodesign	20
Electrical specifications	24
Hydraulic modules	25
User-side exchanger flow rate fields	26
Operating limits	27
Tetris W Rev OH TB	27
Installation advice	28
Water characteristics	28
Glycol mixtures	28
Minimum water content in the system	29
Installation site	30



Tetris W Rev OH TB

ONE MACHINE, MANY SOLUTIONS, NEW BUSINESS OPPORTUNITIES

The new TETRIS W REV OH TB range is a non-reversible water / water heat pump optimized for hot operation. Its operating limits allow the production of hot water up to 80°C. The concept with which the new TEMPERATURE BOOSTER (TB) range was developed is based on the possibility of providing an extreme temperature boost to water sources or water flows available at medium temperature and bringing them to higher temperatures or to produce energy at different temperature levels as for cascade applications.

The TEMPERATURE BOOSTER series can be one of the alternatives that Swegon offers for the replacement of classic heating systems, in particular where high localized system temperatures are required, specifically it can be a valid alternative for those countries whose regulations prohibit the use of traditional combustion boilers. In this sense TETRIS W REV OH TB is presented as a sustainable solution in energy-saving optical thanks to its high efficiency performance.

Most important, referring to the increasing regulations that push towards total decarbonisation in the heating and cooling sector, these units enter the panorama of "virtuous" applications that can cover up the temperature gap generated by medium temperature units such as heat pumps or multifunctional units, going as far as the production of hot sanitary water production or hot water for process applications. The range also fits to inclusion in a district heating network by raising the water temperature where necessary. This avoids the transport of fluids with high temperature over long distances, for example generated by an upstream power plant, causing large energy losses. Finally this solution is perfectly suited to be coupled to different Swegon units such as multifunctional units and heat pumps allowing recover the water produced by these units for secondary heating purposes for a system that need an instant energy boost, this optimize and stimulate energy recovery. Below there is a schematic representation of what can be achieved with our units, creating new business opportunities but above all very high flexibility:

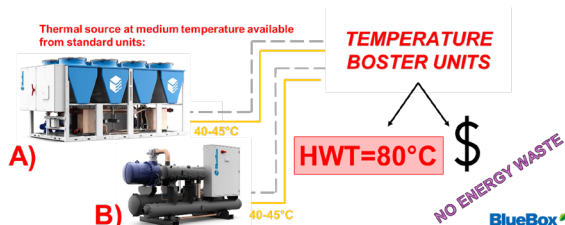

Tetris W Rev OH TB is also the result of a platform developed with modular logic, allowing to obtain a highly flexible and configurable product.

Since this is an indoor unit, the structure has been designed to be as compact as possible: its width of 875mm and height of 1,880mm allow even the largest model to pass easily through the doors of the technical rooms. Furthermore, the unit does not require manifolds for connection of the main heat exchangers and so also the installation space is further reduced.

STRUCTURE

The structure consists of a load-bearing frame made of epoxy polyester powder coated steel sheet, coloured with RAL 7035.

All screws and bolts are stainless steel.

COMPRESSORS

The compressors are of the hermetic scroll type with orbiting spiral connected in tandem, optimized for heat pump applications.

SOURCE-SIDE HEAT EXCHANGER

The exchanger is a braze-welded stainless steel plate heat exchanger, insulated with a shroud of closed-cell insulating material.

Models with 2 refrigerant circuits are fitted with dual circuit heat exchanger and therefore with a single pair of hydraulic connections. This has allowed us to:

- maximize COP levels
- reduce the amount of refrigerant used in the unit
- make the unit lighter and more compact
- make its maintenance easier.

The heat exchanger is fitted with a temperature probe for freeze protection and a paddle flow switch for water flow control.(supplied loose).

USER-SIDE HEAT EXCHANGER

The exchanger is a braze-welded stainless steel plate heat exchanger, insulated with a shroud of closed-cell insulating material.

Models with 2 refrigerant circuits are fitted with dual circuit heat exchanger and therefore with a single pair of hydraulic connections.

REFRIGERANT CIRCUIT

Each refrigerant circuit of the basic unit comprises:

- shut-off valve in the liquid line
- 5/16" charging valves
- liquid sight glass
- replaceable solid cartridge dehydrator filter
- electronic expansion valve
- pressure transducers for reading the high and low pressure values and relevant evaporating and condensing temperatures
- high pressure switches
- low pressure switches (only for models with parametric control)

The pipes of the circuit and the exchanger are insulated with extruded closed-cell expanded elastomer.

Compared to the mechanical expansion valve, the electronic expansion valve allows machine stability to be reached more quickly and better superheating control to maximize the use of the evaporator in all load conditions. This also acts as shut-off valve on the liquid line, as it closes during compressor stops, so preventing dangerous refrigerant migration.

ELECTRICAL CONTROL PANEL

The electrical control panel is made in a painted galvanized sheet-iron box.

The electrical control panel of the basic unit comprises:

- main disconnect switch
- automatic circuit breakers for compressors with fixed calibration
- fuses to protect the auxiliary circuits
- thermal magnetic circuit breakers for the pumps (if present)
- contactors for compressors and pumps (if present)
- phase monitor
- potential-free general alarm contacts
- single potential free operating contacts for compressors and pumps (if present)
- microprocessor controller with display accessible from the outside

All the electrical cables inside the panel are numbered and the terminal board dedicated to the customer's connections is colored orange so that it can be quickly identified in the panel.

The power supply of the unit is 400V/3~/50Hz or 400V/3~+N/50Hz depending on the model and the version

CONTROLLER BLUETHINK

Main controller functions advanced

The control allows the following functions:

- water temperature adjustment, with control of the water entering the user-side heat exchanger
- freeze protection
- compressor timings
- automatic rotation of compressor starting sequence
- recording of the log of all machine inputs, outputs and states
- automatic rotation of compressor starting sequence
- recording of the alarm log
- RS485 serial port with Modbus protocol
- Ethernet serial port with Modbus protocol and integrated web server preloaded web page
- digital input for general ON/OFF

- For further details on available functions and on displayed information, you can refer to the specific documentation of the control.

By default, the serial connections present as standard are enabled only for reading from BMS. Enabling of writing from BMS is to be requested when ordering.

Main functions of the webserver

As standard, the Bluethink controller integrates a webserver with a preloaded web page that is accessed via password.

The web page allows the following functions to be carried out (some of these are available only for users with advanced level rights):

- display of the main functions of the unit such as unit serial n°, size, refrigerant
- display of the general state of the unit: water inlet and outlet temperatures, outdoor air temperature, working mode, evaporating and condensing pressures, suction and discharge temperatures
- display of the status of compressors, pumps, expansion valves
- display in real time of the graphs of the main quantities
- display of the graphs of logged quantities
- display of alarm log
- management of users on several levels
- remote ON/OFF
- remote set point change
- remote time band change

Human-Machine Interface

The control has a graphic display that allows the following information to be displayed:

- water inlet and outlet temperature
- set temperature and differential set points
- description of alarms
- hour meter of operation and number of start-ups of the unit, the compressors and the pumps (if present)
- high and low pressure values, and relevant condensing and evaporating temperatures
- external air temperature
- superheating at compressor suction.

CONTROLS AND SAFETY DEVICES

All the units are fitted with the following control and safety components:

- high pressure switch with manual reset
- high pressure safety device with automatic reset, for a limited number of occurrences, managed by the controller
- low pressure safety device with automatic reset and limited tripping managed by the controller
- high pressure safety valve
- antifreeze probe at outlet of each evaporator
- compressor overtemperature protection
- mechanical paddle flow switch (supplied loose)

TESTING

All the units are factory-tested and supplied complete with oil and refrigerant.

PACKAGING

The unit is made and shipped on a wooden pallet that allows the unit to be handled using a forklift truck.

The unit is wrapped in transparent polyethylene stretch film.

OPTIONS

/LN: silenced unit

The standard unit is realized with sound absorbing panels allowing the highest soundproofing levels and reducing the noises caused by the vibrations of the compressors then transmitted to the adjacent structures.

The panel consists of:

- 6 mm in sound-absorbing expanded polyurethane with a density of 30 kg / m³, 2 mm of sound-absorbing rubber sheet with a density of 3.6 kg / m² between the layers of polyurethane and an additional layer of sound-absorbing polyurethane foam 22 mm thick. Overall thickness of 30 mm.
- soundproofing of the delivery and suction piping of the compressor by means of noise-absorbing insulating material and high noise impedance material.

HYDRAULIC MODULES

All units can be equipped with a hydraulic module in different combinations on the user side, on the source side.

Hydraulic modules with one pump have:

- one pump

Hydraulic modules with two pumps have:

- two pumps
- a check valve on the delivery side of each pump

In the version with 2 pumps of the same type (source or user), these are always one working and one in standby. Switching between the pumps is automatic and is done based on time (to balance the hours of operation of each) or in the event of failure.

User-side hydraulic modules

The hydraulic circuit inside the unit is completely insulated with closed cell insulation material.

The module can have the following configurations:

- /1P: hydraulic module with one pump
- /2P: hydraulic module with two pumps

All the above-mentioned modules have pumps with standard discharge head.

There are also available modules /1PM and /2PM that have pumps with increased available discharge head

Source-side hydraulic modules

The source side pumps are normally switched off and they are switched on a few seconds before the start of first compressor.

When reaching the set point, a few seconds after switching off the last compressor, the source side pumps are switched off again.

The hydraulic circuit inside the unit is fully insulated with closed-cell insulating material.

The module can have the following configurations:

- /1S: hydraulic module with one pump
- /2S: hydraulic module with two pumps

All the above-mentioned modules have pumps with standard discharge head.

The following are also available:

modules /1SM and /2SM that have pumps with increased available discharge head

Hydraulic circuit accessories

FVP FLOWZER VP - Inverter for manual pump adjustment

The accessory consists of inserting an inverter in the machine to manually adjust the speed of the pump (or pumps) in order to calibrate the pump flow rate on the head losses of the system.

This accessory is to be combined with one of the integrated hydraulic modules that can be selected for the unit. Units equipped with integrated hydraulic module allow a certain level of available discharge head (point A) to be obtained under nominal flow rate conditions Q_d .

But the actual head loss level of the system (e.g. characteristic curve R') normally causes the pump to find a different equilibrium point (point B), with a flow rate Q_r higher than Q_d .

In this condition, in addition to having a different flow from the nominal one (therefore also a different temperature jump), there is also a greater absorption of electric power from the pump itself.

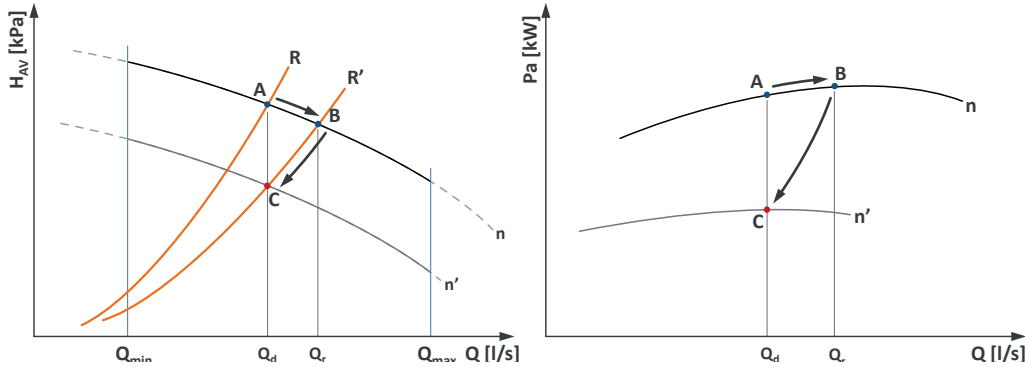

The use of the Flowzer allows the pump speed to be set manually (e.g. at speed n' instead of n) to obtain the design water flow rate and thermal gradient (point C). Once the adjustment procedure has been carried out, the pump will always work at a fixed flow rate.

The adoption of the VP Flowzer allows to considerably reduce the electrical power consumption of the pump with a consequent energy saving. By way of example, a reduction in the flow rate of 10% leads to a reduction in power consumption of around 27%.

For the freecooling units the Flowzer VP is able to manage two different speeds of the pump automatically compensating the pressure drops of the water coil.

FVD FLOWZER VD - control of available pump discharge head for variable flow systems without monitoring the flow rate limits;

Flowzer VD requires two pressure transducers to be installed in the machine. Through these transducers, the inverter can gauge the actual pressure at the ends of the system and it can automatically adapt the pump speed to obtain a set available discharge head value. Flowzer VD must be combined with Flowzer VP. This accessory therefore allows a constant pressure system to be achieved.

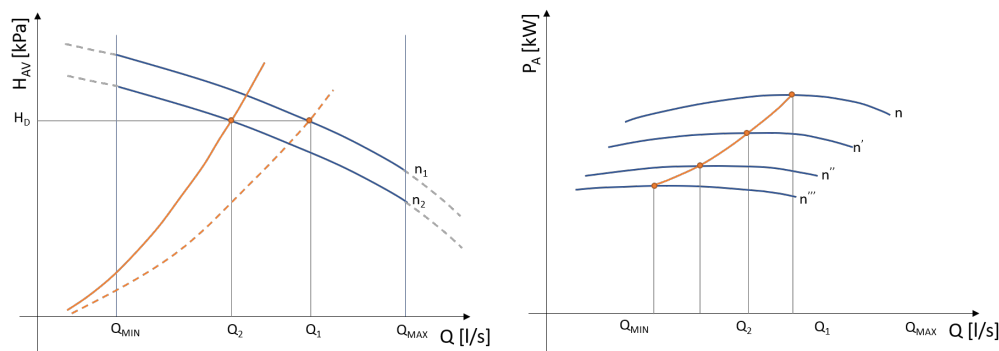

With the Flowzer VD, the customer can set, directly on the display, the available discharge head value (H_d) that the unit must maintain. As can be seen from the graph as the user request decreases, the resistant curve of the plant moves to the left, consequently the inverter reduces the speed of the pump in order to maintain the useful head necessary for the unit. With this system a significant reduction in electrical power is achieved. The customer will have to check that, in minimum flow rate conditions (that is, with the maximum number of user points closed), this is always higher than or equal to the minimum flow rate allowed by the unit.

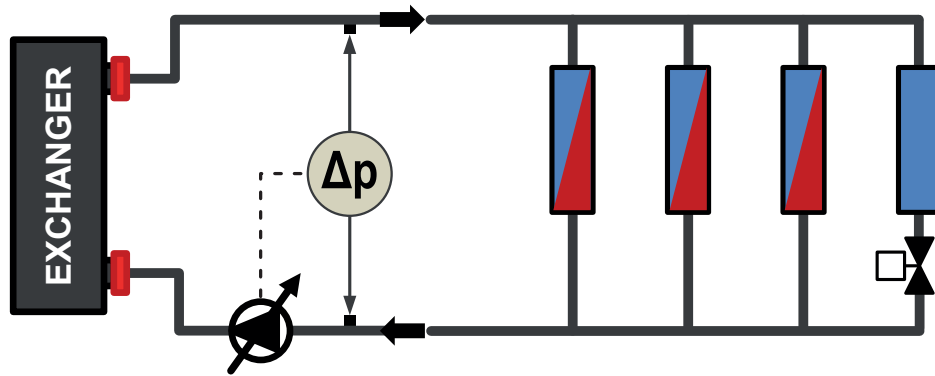

This accessory is useful when the total head losses of the circuit are slightly variable or when they change depending on the seasons (for example, some user points are active only during summer operation and not during winter operation).

The use of this accessory also allows the pump speed to be adapted to possible fouling of the filter on the hydraulic circuit.

The option is not compatible with the Multilogic version. Please refer to the HYZER solutions for the compatibility between variable flow systems and multi-machine systems.

FVDE FLOWZER VDE - flow rate control to keep the flow rate constant as the external working conditions of the system change;

Flowzer VDE requires a differential pressure transducer to be installed in the machine. Through this transducer, the inverter can gauge the actual pressure at the ends of the heat exchanger installed in the machine and it can automatically adapt the pump speed for a constant flow value under all conditions. Flowzer VDE must be combined with Flowzer VP.

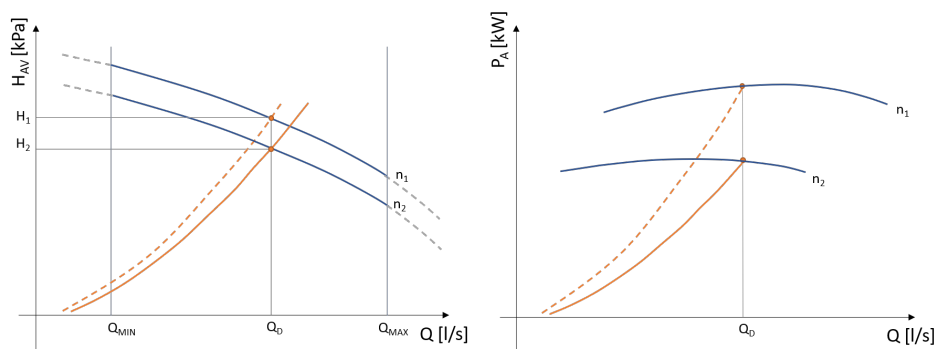

Flowzer VDE is used to automatically adjust the pump speed. As the graph shows, the inverter trips and increases the pump speed if a different condition occurs which would cause an undesired drop in the flow rate (e.g. operation of an external dry cooler). This is a more accurate solution than the VP option alone as it always provides for the water flow (Q_d) required by the design conditions.

VSWU User-side safety valve

With this accessory, a safety valve is inserted in the hydraulic circuit of the unit: when the calibration pressure is reached, the valve opens and, by discharging (to be routed by the customer), prevents the system pressure from reaching limits that are dangerous for the components present in the system. The valves have positive action, that is, performance is guaranteed even if the diaphragm deteriorates or breaks.

VSS Source-side safety valve

With this accessory, a safety valve is inserted in the hydraulic circuit of the unit: when the calibration pressure is reached, the valve opens and, by discharging (to be routed by the customer), prevents the system pressure from reaching limits that are dangerous for the components present in the system. The valves have positive action, that is, performance is guaranteed even if the diaphragm deteriorates or breaks.

COID Upward hydraulic connections

This accessory includes the supply of the semi-finished products necessary for turning the hydraulic connections of the unit upwards. The installation of semi-finished products outside the machine is to be carried out by the customer.

Accessory supplied loose.

V3 Three-way valve for domestic hot water management

This is a three-way on-off valve, complete with servo control. The unit controller can manage two separate hydraulic circuits through this valve: one for comfort and one for domestic hot water production.

The valve and the servo control are for indoor installation and they require the ambient temperature not to drop below -10°C .

Accessory supplied loose. Installation by the customer.

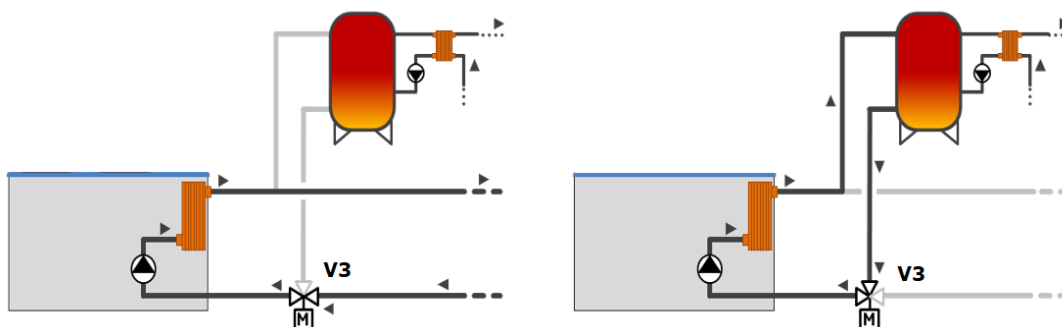

V3MC 3-way modulating valve on hot circuit

The accessory involves the supply of a 3-way modulating valve to be inserted on the hot circuit in order to check that the temperature of the water leaving the exchanger is always higher than the minimum allowed.

Accessory supplied loose. Installation by the customer.

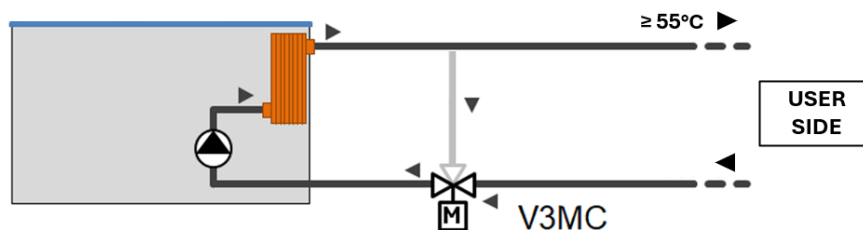

Refrigerant circuit accessories

DVS Double safety valve

With this accessory, instead of each individual safety valve per circuit, there is a "candelabrum" with two safety valves and a diverter valve for choosing the valve in operation. This allows the safety valves to be replaced without having to drain the machine and without having to stop it.

RUB Compressor suction and delivery valves

The valves situated on the delivery side and on the suction side of the compressors allow the compressor to be isolated from the rest of the refrigerant circuit, so making the maintenance operations quicker and less invasive

BC Capacitive backup battery for electronic expansion valve

When the compressors stop, the controller always closes the electronic expansion valve to prevent dangerous refrigerant migration. The presence of the backup battery ensures that the electronic valve is kept in closed position even when there is no power supply

This option uses a condenser as energy storage, and not an ordinary coil. In this way, it is not affected by the memory effect of normal coils and the need for maintenance is avoided.

Applies to units with advanced controller.

RPP Refrigerant leak detector with automatic pump down

With this accessory, a refrigerant leak detector is placed inside each compressor compartment. Detection of a refrigerant leak is managed by the control through a specific alarm and display of a specific icon on the display of the control. For all the circuits of the unit, the alarm also starts the machine stopping procedure with pump down, confining all the refrigerant in the coils.

The accessory includes the capacitive backup battery.

RPR Refrigerant leak detector

With this accessory, a refrigerant leak detector is placed inside each compressor compartment.

For units supplied with advanced controller, the detection of a refrigerant leak is managed by the controller through a specific alarm and display of a specific icon on the display of the controller. This alarm stops the unit.

For units supplied with parametric controller, a LED light goes on outside the electrical panel to warn about the leak. Provision is made for a potential-free contact to trigger the alarm.

MAFR Pressure gauges

The operating pressures of each circuit of the unit can be displayed on the control by accessing the relevant screens. Also, the machine can be fitted with pressure gauges (two for each circuit) installed in a clearly visible position. These allow reading in real time of the working pressures of the refrigerant gas on the low pressure side and on the high pressure side of each refrigerant circuit.

Electrical accessories

SETD Double set point from digital input

The accessory allows you to preset two different operating set points and manage the change from one to the other through a digital signal.

The set point temperatures must be specified when ordering.

Unless otherwise specified in the order, the controller will be set at the factory with the following temperatures:

- set point 1 at 45 ° C and set point 2 at 40 ° C

For operating conditions other than standard, unless otherwise specified in the order for the second set point, the controller will be set at the factory:

- by subtracting 5°C from the main set point

If necessary this value will however be limited to remain within the operating limits of the unit.

SETV Variable set point with remote signal

The accessory allows the set point to be varied continuously between two preset values, a maximum and a minimum, depending on an external signal that can be of the 0-1V, 0-10V or 4-20mA type.

The set point temperatures and the type of signal to use for the adjustment must be specified when ordering.

Unless otherwise specified in the order, the controller will be set at the factory with 0-10V analogue input and with the following temperatures:

- 0V will correspond to the 45 ° C set point and 10V will correspond to a 40 ° C set point

For operating conditions other than standard, unless otherwise specified in the order for the variable set point, the controller will be set at the factory:

- by subtracting 5°C (10V) from the main set point (0V)

If necessary this value will however be limited to remain within the operating limits of the unit.

LIID Limitation of the current absorbed by digital input

When this accessory is requested, a digital input is prepared in the terminal board to activate the forced capacity reduction of the unit to a set fixed level.

This accessory is useful when there is a need to necessarily limit the power absorbed by the unit as regards particular conditions.

We point out that, in some conditions (for example, during defrosting, oil return cycles or hourly compressor rotation procedures), the controller could force the unit to operate at full capacity for limited periods of time.

CSP Set point compensation depending on external air temperature

For units fitted with this accessory, the set point of the unit is set so that it can vary between two values, a maximum and a minimum, depending on the external air temperature. The compensation ramp and the maximum and minimum values of the set point can be changed by the user.

Unless otherwise specified in the order, the controller will be set to implement a positive compensation logic according to the temperatures shown in the following diagrams:

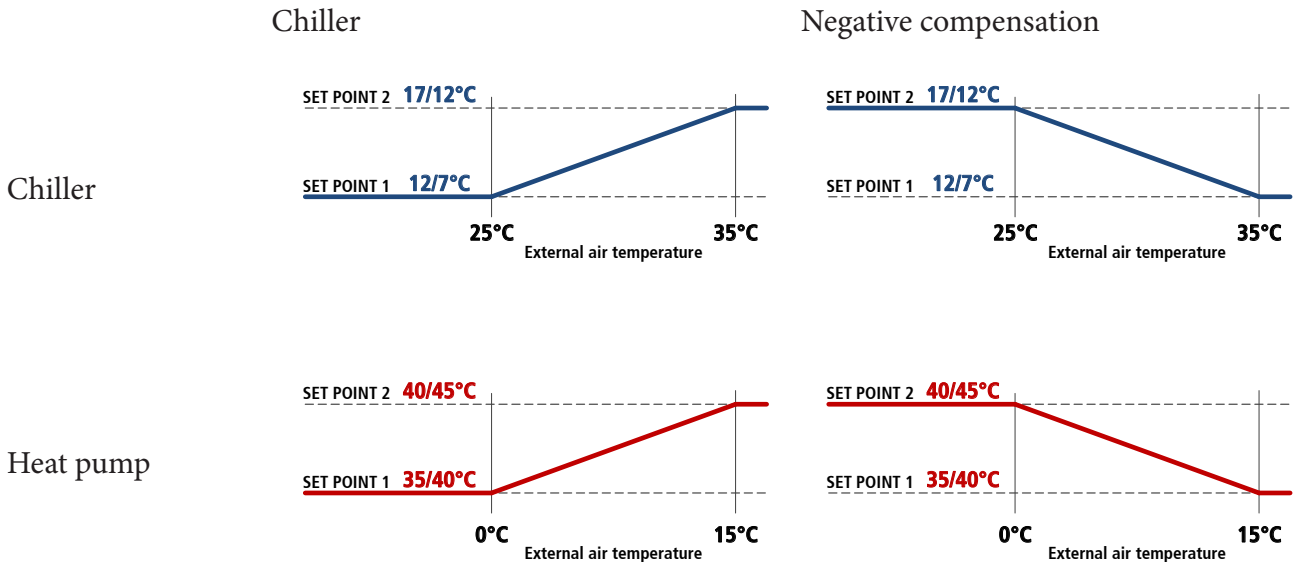

RMMT Maximum and minimum voltage relay

This accessory constantly monitors the voltage value and the unit's power supply phase sequence. If the supply voltage does not fall within the set parameters or there is a phase reversal, an alarm is generated that stops the machine to prevent damage to its main parts

TERM Remote-controlled user terminal panel

This accessory allows the terminal normally situated on the machine to be replicated on a support situated at a distance. It is particularly suitable when the unit is placed in an area that is not easily accessible.

The accessory is supplied loose and is to be installed by the customer at a maximum distance of 120m from the unit. We advise using a cable of the following type: "TECO O.R. FE 2x2xAWG24 SN/ST/PUR".

For this accessory, there is a dedicated serial port.

SOFT Electronic soft-starter

The scroll compressors have DOL (Direct On Line) starting and their torque (T) and current (I) characteristics are shown in the following diagrams:

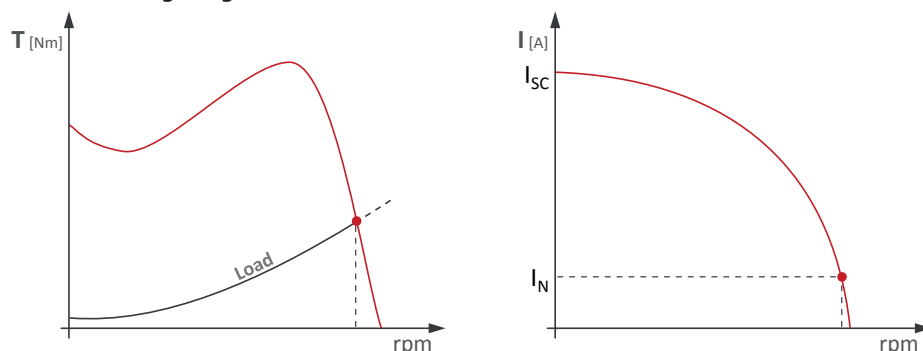

For an individual compressor, the normal starting current I_{SC} will be 4-5 times its rated current I_N .

If the unit is equipped with the electronic soft-starter accessory, the starting of each compressor is done with an acceleration ramp that allows the effective value (rms value) of the inrush current of the individual compressor to be lowered.

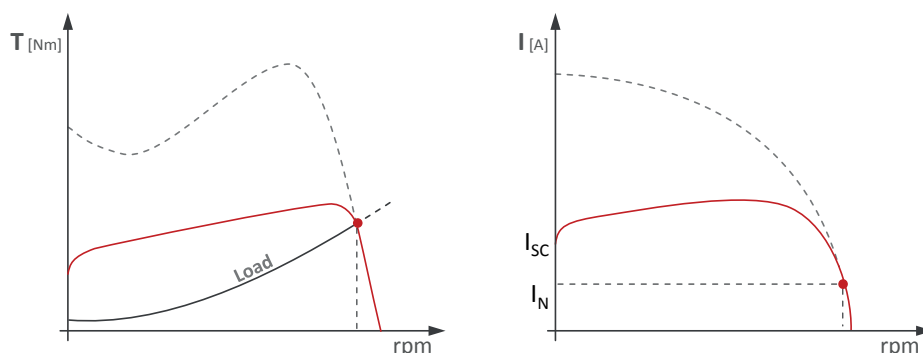

R1PU Relay for management of 1 external user-side pump

This accessory can be requested for units without user-side pumps and allows a pump outside the machine to be controlled.

R2PU Relay for management of 2 external user-side pumps

This accessory can be requested for units without user-side pumps and allows two pumps outside the machine to be controlled with a running/stand-by logic by implementing a rotation on the hours of operation.

The two pumps are controlled by two separate relays.

RE1S Relay for management of 1 external source-side pump

This accessory can be requested for units without source-side pumps and allows a pump outside the machine to be controlled.

RE2S Relay for management of 2 external source-side pumps

This accessory can be requested for units without source-side pumps and allows two pumps outside the machine to be controlled with a running/stand-by logic by implementing a rotation on the hours of operation.

The two pumps are controlled by two separate relays.

COTW Outgoing water temperature control

With this accessory, outgoing instead of incoming water temperature control is used.

DAA Double power supply with automatic switching

A motor-driven automatic switch to which to connect two separate power supply lines (for example, one from the mains power line and one from the uninterruptible power supply unit) is installed in the electrical control panel of the unit.

The switching from one line to another is automatic and obligatorily requires passing through the OFF position. When this accessory is requested, the power supply of the unit must compulsorily include neutral.

DAM Double power supply with manual switching

A manual switch to which to connect two separate power supply lines (for example, one from the mains power line and one from the uninterruptible power supply unit) is installed in the electrical control panel of the unit. The switching from one line to another is manual and obligatorily requires passing through the OFF position.

IA Automatic circuit breakers (instead of fuses)

This accessory requires the installation of automatic circuit breakers, instead of fuses, for the protection of auxiliary loads. Also, the same accessory uses automatic circuit breakers with adjustable thermal overload protection to protect the compressors.

RIF Power factor correction to $\cos\phi \geq 0.95$

With this accessory, an electrical control panel (IP54 protection rating), containing power factor correction capacitors to make the $\cos\phi$ of the unit greater than or equal to 0.95, is supplied with the unit. The capacitors should be connected (by the customer) to the electrical control panel of the unit in the specially prepared terminal board.

Besides reducing the absorbed reactive power, the use of this accessory also allows the maximum absorbed current to be lowered.

SFU User-side remote-controlled operating probe

With this accessory, the operating probe is to be placed on a tank outside the machine. When the set point temperature is reached in the tank, the unit also stops the pumps to guarantee the maximum energy saving. The circulation of water in the tank to the system is to be provided by the customer.

The accessory is available only for units with built-in user-side hydraulic module or with the "Relay for management of 1/2 external user-side pumps" accessory.

ENT Energy trend

This function estimates the energy consumption and the cooling and heating production of the unit. The efficiency of the unit is calculated ("EER" for cooling operation or "COP" for heating operation).

Data are calculated in real time according to the working conditions of the unit (evaporation and condensing pressure, external air temperature).

Data are also displayed in the unit user interface in a dedicated "Energy Trend" mask.

Following data are also recorded in the logs in the controllers memory:

- "EnergyTrendHours" contains records of the values of energy absorbed and produced for each hour
- "EnergyTrendHistory" contains records of the values of energy absorbed and produced for each day

The "logs" can then be downloaded via a USB pendrive or from the WEB pages.

The function returns values within the operating envelope of the machine. No data will be recorded outside the operating envelope. The data is stored as an hourly average for 12 months of operation. After 12 months the control overwrites the first data. If hourly resolution is required, the data must be downloaded at least once a year. The control also stores daily average data. This is stored for the life of the unit. In case of microprocessor board failure, data, if not previously downloaded and saved, will be lost.

AS Automatic management of domestic hot water

This function enables the unit to control the temperature inside a domestic hot water storage tank and to manage a 3-way valve outside the unit (available as an accessory).

The water temperature in the domestic hot water tank is controlled through a dedicated probe situated in the tank.

Normally, the heat pump operates on the system to meet the comfort requirements of the building, but when the water temperature in the domestic hot water tank falls below a set threshold, the controller switches to domestic hot water production.

If the unit is operating as heat pump for heating, the 3-way valve will be switched and the set point changed. Once the temperature in the domestic hot water tank has reached the set value, the unit automatically returns to producing water for the heating or air conditioning system.

Domestic hot water production is always given priority.

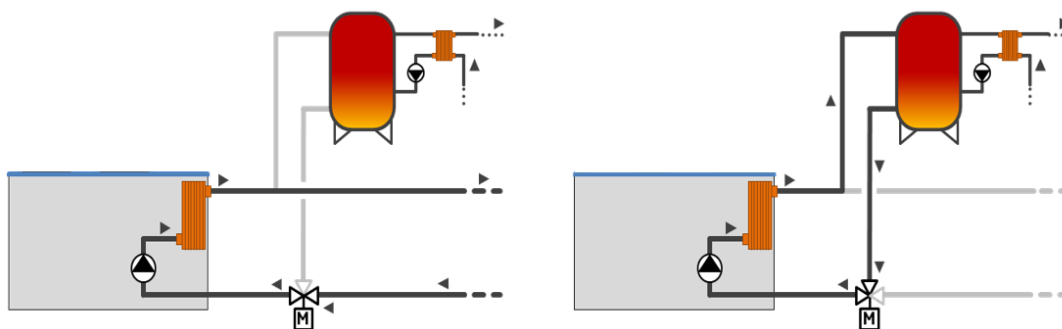

This accessory provides for the presence in the electrical panel of two digital inputs for disabling, respectively, the production of domestic hot water and the production of water for the heating system.

When the unit is working in "domestic hot water only" mode, the pump is normally off and is switched on only for the time required to meet the demand for domestic hot water production.

When this accessory is fitted, the machine must have control of pump operation. This means that either the unit is equipped with one of the hydronic modules available in the catalogue (therefore with at least one pump installed on it) or the relay for external pump management must be requested as accessory.

The probe to be placed in the sanitary tank is supplied with a 12m long cable. The probe is used to measure the water temperature in the hottest part of the tank, so it must be positioned in a specially prepared pocket and secured using heat conducting paste. Installation by the customer.

In case of management with variable water flow, the installation must necessarily be made with the derivation towards the domestic hot water tank upstream of any bypass valve or channel.

SV3 Signal for 3-way modulating valve

In the electrical control panel, a 0-10V output is preset to be used to control a 3-way modulating valve inserted on the hot circuit.

If the temperature of the water entering the hot exchanger is too low (for example, after the machine has been stopped for an extended period), through this signal, the controller of the unit will control the valve so as to recirculate part of the flow rate at the outlet and ensure that the unit always works within the operating limits.

The 3-way modulating valve is not included in this accessory, but can be requested as further accessory.

Network accessories

SMAR Smartlink function predisposition

This accessory makes it possible to connect the controller of the unit with the controller of a Swegon GOLD™ air handling unit via a simple serial cable, so allowing their operating logics to be merged into a single consciousness that pursues the maximum energy efficiency of the system. The RS485 serial interface is already included and dedicated to connection with Swegon units.

The option is incompatible with:

- double set point
- variable set point with remote signal
- summer/winter selection by digital input
- set point compensation depending on external air temperature
- multilogic
- all communication protocols.

SMAP Setup of Smartlink+ functions

This option is used to connect the controller in the unit with the controller of a Swegon GOLD™ air handling unit via the Ethernet port TCP/IP, so allowing the operating logics of hydronic and ventilation systems to be merged into a single logic for the achievement of maximum energy efficiency and comfort. This option is only available for units featuring an advanced controller and it is compatible with Multilogic and Hyzer systems only if the machine is the Master.

The option is incompatible with:

- double set point
- variable set point with remote signal
- set point compensation depending on external air temperature
- all communication protocols.

PSN SNMP protocol

The accessory consists of a gateway that allows Ethernet connection to a SNMP manager supervision system. The use of this accessory causes the RS485 serial port to be unavailable.

SW4P Network switch with 4 ports

The accessory includes installation in DIN rail of a professional 4-port network switch. Requires Blueye via Ethernet.

SW8P Network switch with 8 ports

The accessory includes installation in DIN rail of a professional 8-port network switch. Requires Blueye via Ethernet.

GLO Modbus Lonworks Gateway

With this accessory, a RS485/Lon gateway is installed inside the electrical control panel.

By default, the programming gives read-only access to the control of the unit. Reading / writing access is activable on field with a service level.

PBA BACnet protocol over IP (Ethernet)

The controller is set for use, in read and write mode, of the BACnet port on IP protocol.

By default, the programming gives read-only access to the control of the unit. Reading / writing access is activable on field with a service level.

FMx Multilogic Function

The Multilogic function allows management of up to 32 units equipped with advanced Bluethink controller and connected in hydraulic parallel with each other.

Multilogic systems only operate with the "Ipro" advanced controller and if the connected units have the same software version. A Multilogic network cannot operate with different software versions/releases.

On the basis of the information recorded by the temperature probes installed on the delivery and return manifolds of the system, with the master unit, a capacity request is generated that is distributed among the units connected in the Multilogic network according to settable priority and optimization logics.

If communication between the units fails or if the master is off-line, the slave units can continue to work according to the set thermoregulation parameters.

The connected units can be different from each other, in terms of capacity and set-up, provided the following rules are complied with:

- if there are both chiller units and heat pumps in the Multilogic network, the Master unit must obligatorily be one of the HP units
- if there are both free cooling and non free-cooling units in the Multilogic network, the Master unit must obligatorily be one of the free-cooling units.

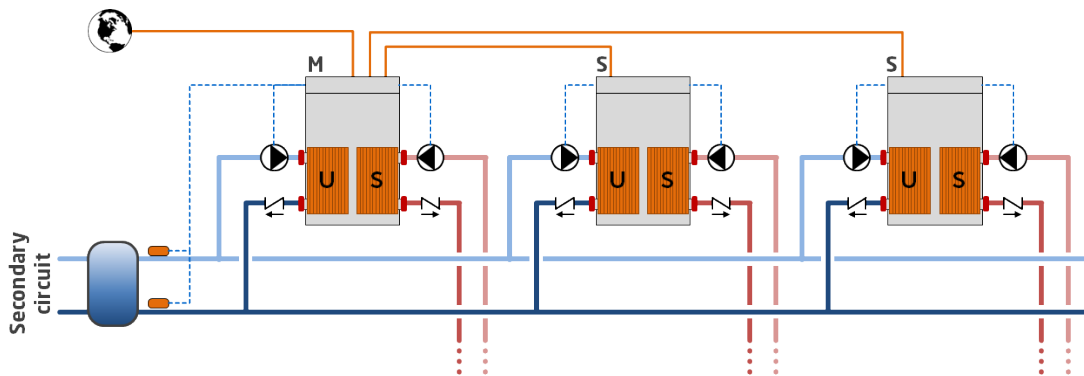

The Multilogic function that can be requested with the unit can be:

- **FM0:** Multilogic function for Slave unit
- **FM2:** Multilogic function for Master unit for managing up to 2 Slaves
- **FM6:** Multilogic function for Master unit for managing up to 6 Slaves

If you need to connect more than 6 slaves (up to 31), you can ask for a quotation from our sales department.

For the slave units, the accessory includes:

- programming of the unit as slave of a system of machines in Multilogic network

For the master units, the accessory includes:

- programming of the unit as master of a system of machines in Multilogic network
- entering of the parameters necessary for connection with the individual slave units
- installation in the electrical control panel of a network switch to allow the units to be connected in a LAN network.
- the supply of 2 temperature probes to be positioned on the delivery and return manifold of the system (supplied separately with it, installation and wiring by the customer)

The connection between the master unit and the slave units made with a CAT cable. 5E/UTP (prepared by the customer) with RJ45 connectors. Maximum cable length 100m.

For further details, please refer to the controller manual.

BEET Blueye® via Ethernet

Blueye® is a supervision platform that enables remote monitoring of one or more units in the same system interconnected through a network with Modbus protocol.

This accessory features the Blueye device, as already installed and wired in the unit.

The critical variables to be monitored over time are identified for each connected device. These variables are sampled and saved to the cloud so that they are accessible at all times through a web portal or a mobile APP (available for Android and iOS).

The following options can be selected for connection to the internet:

- a LAN (Ethernet) connection - available in the system;
- a connection to a mobile network - at least 3G. The data SIM card is not included.

Three different types of contracts can be signed.

Blueye® Cloud Basic:

- to monitor a max. of 20 variables in total over max. 5 units/peripherals;
- to set a min. sampling frequency of 60 seconds.

Blueye® Cloud Advanced:

- to monitor a max. of 200 variables in total over max. 10 units/peripherals;
- to set a min. sampling frequency of 5 seconds.

Blueye® Connect:

- To monitor up to 10 units/peripherals.

Subscribing to any of the **Blueye® Cloud** enables:

- viewing the history of the monitored variables, in the form of both numerical values and graphs;
- downloading the history of variables in CSV format;
- the creation of automatic reports;
- setting notifications (via APP or mail) with settable thresholds for each variable;
- switching the unit ON/OFF remotely;;;
- changing the set point remotely;
- selection of SUMMER/WINTER mode remotely (for reversible units only).

The subscription to the **Blueye® Connect** service offers the advantages below:

- a safe connection (tunnelling) between the user and the remote unit through the Blueye® portal;
- full access to the remote controller;
- real time monitoring;
- software upgrading.

Blueye® via Ethernet is only available for units supplied with an advanced controller and does not include any type of service. This service must be purchased separately based on the number of units/devices to be connected and the number of variables to be monitored. In order to connect multiple units to **Blueye® device, the network switch is required (this accessory is sold separately).**

Units can also be connected to the Blueye device through the RS485 network featuring a Modbus RTU protocol (for this option, refer to BERS accessory).

For further details, refer to the specific Blueye® documentation.

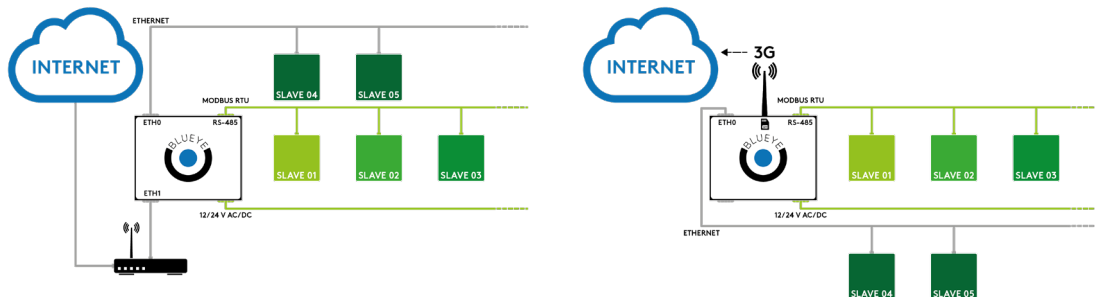

Other accessories

AG Rubber anti-vibration mounts

These allow you to reduce the vibrations transmitted from the unit to the surface it is standing on.
Accessory supplied loose.

AM Spring anti-vibration mounts

These allow you to reduce the vibrations transmitted from the unit to the surface it is standing on.
Accessory supplied loose.

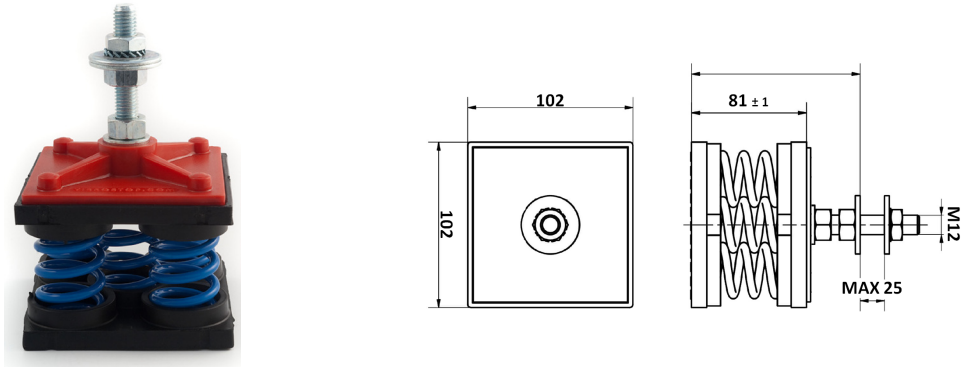

GABB Packaging in wooden crate

The unit is protected by a custom-made wooden cage, including a wooden sled designed for loading into containers and a fixing system. The accessory can be used for container shipping. Loading on containers must be carried out at the factory. The accessory is incompatible with "Skid for shipping in containers".

MOIB Basic hydraulic module

The accessory consists of a carpentry extension that allows the installation of more than two pumps inside the machine room. For more information on the variation of carpentry dimensions, contact the sales department.

PREA Unit suitable to be disassembled on site

The unit is delivered so that it can be disassembled easily on site if this makes the installation operations easier.

A unit requested with this option is supplied:

- screwed instead of riveted
- with plugged and not welded pipes
- without refrigerant charge
- untested
- covered by the warranty only if reassembled and screwed together by personnel authorized by the factory

KFW Water filter kit

To protect the elements of the hydraulic circuit (in particular, the exchangers), there are Y filters that can stop and settle the particles that are normally present in the water flow and would otherwise settle in the more delicate parts of the hydraulic circuit and damage its heat exchange capacity.

The kit involves the supply of a filter for each exchanger present in the machine.

Installation of the water filter is mandatory even when it is not supplied as an accessory.

Accessory supplied loose.

BOO **BoosterLink**

BoosterLink is the ideal solution to manage the "Temperature Booster" unit when using a Swegon heat pump as a source. The use of the "Boosterlink" guarantees the correct management of the units and prevents inefficiencies in the hydraulic system and failures.

BoosterLink consists of an independent electrical panel which contains a programmable controller with dedicated software, a 4.3" Touch interface and an Ethernet switch.

BoosterLink connects via Ethernet to the "Temperature Booster" unit and to the source heat pump unit.

Main features of BoosterLink:

- 3-way mixing valve management installed on the source side of the "Temperature Booster" in order to correctly adjust the temperature of the evaporator inlet water
- Automatic compensation of the water production set point of the "Temperature Booster" in order to avoid excessive cooling of the evaporator side circuit which could cause malfunctions on the source heat pump
- Synchronization of the start-up and shutdown phases of the 2 units ("temperature Booster" and source heat pump)
- Set-point configuration and alarm display of the two units

BoosterLink is equipped with a user friendly Touch interface that allows you to configure the system and monitor its operation through a synoptic that displays the user-side and source-side system water temperatures and the percentage of opening of the mixing valve.

The application with the BoosterLink manager is designed for systems for operation in combination with heating-only source (heat pump in heating mode or the hot side heat exchanger of a multi-purpose).

The source side unit must not be used for the production of chilled water, and must be equipped with the "PBL - Arrangement for connection to BoosterLink" accessory.

On the source side it is possible to use a multi-machine system with the Multilogic option. The BoosterLink will be connected to the Master unit.

On the user side it is not possible to create a multi-machine system.

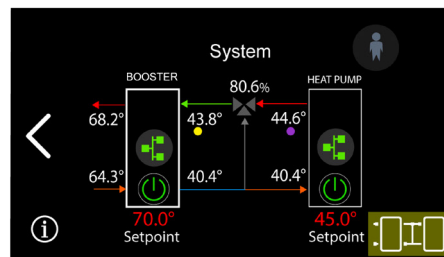

V3B **3-way valve for BoosterLink**

It is a modulating three-way valve complete with actuator. This valve is controlled using the "BoosterLink" accessory in order to correctly adjust the inlet water temperature to the evaporator of the "Temperature Booster" unit in systems where a Swegon heat pump is used as the source unit.

The valve and the servo control are for indoor installation and they require the ambient temperature not to drop below -10°C.

Accessory supplied. Installation by the customer.

TECHNICAL SPECIFICATIONS

TETRIS W REV OH TB

			7.2	8.2	9.2	11.2	14.2	17.2	22.2	27.2
Heating										
Heating capacity	(1)	kW	69,1	78,1	90,5	114	136	173	216	267
Total absorbed power	(1)	kW	16,3	17,5	20,5	27	33	43,2	52,8	64,8
COP	(1)		4,24	4,46	4,41	4,22	4,12	4	4,09	4,12
Compressors										
Compressors/Circuits		n°	2/1	2/1	2/1	2/1	2/1	2/1	2/1	2/1
Minimum capacity reduction step	(2)		50%	50%	50%	50%	50%	50%	50%	50%
Refrigerant charge		kg	8	9	11	13	16	20	25	31
User-side heat exchanger										
Quantity		n°	1	1	1	1	1	1	1	1
Water flow rate	(1)	m³/h	7	8	10	12	15	19	23	29
Head loss	(1)	kPa	14,9	14,9	14,8	19,9	19,8	20	19,9	20
Source-side heat exchanger										
Quantity		n°	1	1	1	1	1	1	1	1
Water flow rate	(1)	m³/h	9	11	12	15	18	22	28	35
Head loss	(1)	kPa	14,7	14,7	19,6	19,6	24,6	24,8	24,6	24,7
Noise levels										
Sound power lev.	(4)	dB(A)	77	77	77	81	85	86	88	90
Sound pressure lev.	(5)	dB(A)	62	62	62	66	70	70	72	74
Lev. Sound power vers. LN	(4)	dB(A)	70	70	70	74	78	79	81	83
Lev. Sound pressure vers. LN	(5)	dB(A)	55	55	55	59	63	63	65	67
Dimensions and weights**										
Length		mm	1633	1633	1633	1633	1633	1633	1633	1633
Depth		mm	792	792	792	792	792	792	792	792
Height		mm	967	967	967	967	967	1880	1880	1880
Operating weight	(3)	kg	410	430	470	490	500	700	770	830
			14.4	16.4	18.4	23.4	28.4	35.4	43.4	53.4
Heating										
Heating capacity	(1)	kW	141	159	184	231	276	351	429	531
Total absorbed power	(1)	kW	32,9	35,2	41,3	54,6	66,9	87,1	107	131
COP	(1)		4,29	4,52	4,46	4,23	4,13	4,03	4,01	4,05
Compressors										
Compressors/Circuits		n°	4/2	4/2	4/2	4/2	4/2	4/2	4/2	4/2
Minimum capacity reduction step	(2)		25%	25%	25%	25%	25%	25%	25%	25%
Refrigerant charge		kg	21	24	28	35	41	52	72	91
User-side heat exchanger										
Quantity		n°	1	1	1	1	1	1	1	1
Water flow rate	(1)	m³/h	15	17	20	25	30	38	46	57
Head loss	(1)	kPa	10,5	10,6	10,5	10,6	10,5	13,7	15,3	15,3
Source-side heat exchanger										
Quantity		n°	1	1	1	1	1	1	1	1
Water flow rate	(1)	m³/h	19	21	25	30	36	46	56	69
Head loss	(1)	kPa	14,9	15,8	16,9	19	26,6	31,9	30,2	30,4
Noise levels										
Sound power lev.	(4)	dB(A)	80	80	80	84	88	89	91	93
Sound pressure lev.	(5)	dB(A)	63	63	63	67	71	72	74	76
Lev. Sound power vers. LN	(4)	dB(A)	73	73	73	77	81	82	84	86
Lev. Sound pressure vers. LN	(5)	dB(A)	56	56	56	60	64	65	67	69
Dimensions and weights**										
Length		mm	2017	2017	2017	2017	2017	2834	2834	2834
Depth		mm	872	872	872	872	872	872	872	872
Height		mm	1880	1880	1880	1880	1880	1880	1880	1880
Operating weight	(3)	kg	760	770	780	800	830	1240	1380	1610

(1) Source-side heat exchanger inlet-outlet water temperature 45/40°C; user-side heat exchanger inlet-outlet water temperature 70/78°C. Values compliant with standard EN 14511

(2) Approximate value. The minimum capacity reached by the unit depends on the operating conditions. The value shown may not be suitable for calculating the minimum volume of water: to do this, consult the "Minimum water content in the system" section.

(3) The weight refers to the unit without any accessory. The introduction of some accessories such as hydraulic modules or recovery exchangers can lead to increased weight that can exceed 10%. For further details refer to the specific drawing of the selected configuration.

(4) User-side heat exchanger water inlet/outlet temperature 47/55°C (SCOP MT), Average climate profile, with reference to regulation 2013/813 and norm EN 14825.

(5) Values obtained from the sound power level (condition in note 4), referred to a distance of 1 m from the unit in free field with directivity factor Q = 2. Non-binding values.

** Basic unit without included accessories

ECODESIGN

INTRODUCTION

The Ecodesign/ErP Directive (2009/125/EC) lays down new standards for more efficient energy use.

The Directive contains various regulations; as regards chiller products and heat pumps, the regulations of interest are the following:

- Regulation 2013/813, for small heat pumps ($P_{\text{design}} \leq 400$ kW)
- Regulation 2016/2281, for chillers and heat pumps with $P_{\text{design}} > 400$ kW
- Regulation 2013/811, for heat pumps with $P_{\text{design}} \leq 70$ kW.

The last-mentioned regulation (2013/811) regards the labelling (Ecolabel certification) of small heat pumps.

The other two regulations (2013/813 and 2016/2281) set seasonal efficiency targets that the products must comply with to be sold and installed in the European Union (essential requirement for CE marking).

These efficiency limits are defined through ratios, which are respectively:

- η_{sh} (SCOP), with reference to regulation 2013/813
- η_{sc} (SEER) for comfort applications and SEPR for process applications, with reference to regulation 2016/2281.

The figure below schematically illustrates the correspondence between product and reference energy ratio.

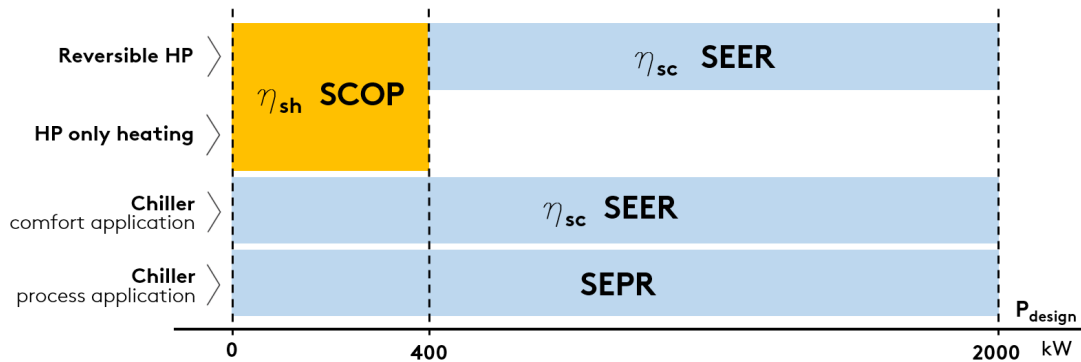

Some notes and clarifications:

For comfort applications, regulation 2016/2281 sets the η_{sc} (SEER) ratio in two different operating conditions:

- SEER calculated with machine inlet/outlet water temperature of 12/7°C (low temperature application),
- SEER calculated with machine inlet/outlet water temperature of 23/18°C (medium temperature application).

The minimum efficiency requirement is the same, but can be met at condition 12/7°C or at condition 23/18°C, depending on the application envisaged for the machine.

Regulation 2013/813 distinguishes two different types: at low temperature and at medium temperature.

The following refer to the application at low temperature: (low temperature application) all heat pumps whose maximum delivery temperature for heating purposes is lower than 52°C with source at temperature of -7°C and -8°C wet bulb (air-water unit) or inlet 10°C (water-water unit), at the reference design conditions for an average climate. For these, the efficiency ratio is "low temperature application" (outlet water temperature 35°C).

For all the other heat pumps, the efficiency ratio is related to "medium temperature application" (outlet water temperature 55°C).

The ratios must be calculated according to the reference European heating season in average climatic conditions.

The minimum efficiency requirements set by the regulations are indicated below.

REGULATION 2016/2281, comfort application

TYPE OF UNIT		MINIMUM REQUIREMENT	
SOURCE	P _{design}	η_{sc} [%]	SEER
air	< 400 kW	161	4,1
air	\geq 400 kW	179	4,55
water	< 400 kW	200	5,075
water	\geq 400 kW and < 1500 kW	252	6,375
water	\geq 1500 kW	272	6,875

REGULATION 2016/2281, process application

TYPE OF UNIT		MINIMUM REQUIREMENT
SOURCE	P _{design}	SEPR
air	< 400 kW	5
air	\geq 400 kW	5,5
water	< 400 kW	7
water	\geq 400 kW and < 1500 kW	8
water	\geq 1500 kW	8,5

REGULATION 2013/813

SOURCE	APPLICATION	MINIMUM REQUIREMENT	
		η_{sh} [%]	SCOP
air	low temperature application	125	3,2
water	low temperature application	125	3,325
air	medium temperature application	110	2,825
water	medium temperature application	110	2,95

The conformity of the product must be checked according to the type of application, whether comfort or process, and at the required outlet water temperature.

The two schematic tables below, respectively for comfort application and for process application, indicate the reference of the required conformity according to the type of product and the set point temperature (reference to regulations 2016/2281 and 2013/813).

Important note: for mixed comfort and process applications, the reference application for conformity is the comfort application.

COMFORT APPLICATION

PRODUCT	OUTLET WATER TEMPERATURE	COMPLIANCE INDEX	REGULATION
Chiller	< 18°C	SEER/ηsc low temperature application	2016/2281
	≥ 18°C	SEER/ηsc medium temperature application	2016/2281
Heat pumps (reversible and only heating) Pdesign ≤ 400kW		SCOP/ηsh	2013/813
Reversible heat pumps Pdesign > 400kW	< 18°C	SEER/ηsc low temperature application	2016/2281
	≥ 18°C	SEER/ηsc medium temperature application	2016/2281
Heat pumps only heating Pdesign > 400kW		-	-

- = exemption from Ecodesign

PROCESS APPLICATION

PRODUCT	OUTLET WATER TEMPERATURE	COMPLIANCE INDEX	REGULATION
Chiller	≥ +2°C , ≤ 12°C	SEPR	2016/2281
	> 12°C	-	-
	> -8°C , < +2°C	-	-

- = exemption from Ecodesign

Partly completed machinery

The term partly completed machinery refers to all units without a user-side or source-side heat exchanger, and therefore to all LC, LE, LC/HP and LE/HP versions. Since these are "non-complete" machines, conformity with Ecodesign depends on combination with the remote heat exchanger.

All the partly completed machinery is CE marked and accompanied by a declaration of conformity. Installation in European Union countries is therefore allowed; correct selection and installation of the remote heat exchanger must be ensured, in accordance with the above cases.

TETRIS W REV OH TB RANGE

Specifically, as regards the Tetris W Rev OH TB range, the regulations of interest are as follows:

- regulation 2013/813 from size 7.2 to 53.4
- regulation 2013/811 (SCOP LT) for units from size 7.2 to 9.2

The tables below give information on the conformity of the units and the seasonal energy performance ratios with regard to the reference regulation.

TETRIS W REV OH TB

			7.2	8.2	9.2	11.2	14.2	17.2	22.2	27.2
REGULATION 2013/813										
Medium Temperature Application										
Pdesign	(2)	kW	43,1	49,7	57,8	72,5	87,6	112	139	172
η_{sh}	(2)	%	161,4	166,8	166,2	170	163,8	163,6	167,1	170,1
SCOP	(2)		4,23	4,37	4,35	4,45	4,3	4,29	4,38	4,45
Compliance	(2)		Y	Y	Y	Y	Y	Y	Y	Y
REGULATION 2013/811										
Ecolabel MT	(3)		A+++	A+++	A+++	-	-	-	-	-
			14.4	16.4	18.4	23.4	28.4	35.4	43.4	53.4
REGULATION 2013/813										
Medium Temperature Application										
Pdesign	(2)	kW	88,2	101	118	148	178	228	278	344
η_{sh}	(2)	%	167,2	172,6	171,5	175,1	167,8	168,3	167,8	171,8
SCOP	(2)		4,38	4,52	4,49	4,58	4,4	4,41	4,4	4,5
Compliance	(2)		Y	Y	Y	Y	Y	Y	Y	Y
REGULATION 2013/811										
Ecolabel MT	(3)		-	-	-	-	-	-	-	-

Y = unit in compliance with Ecodesign at the indicated condition.

N = unit not in compliance with Ecodesign at the given condition: it can be installed only in non-EU countries.

(2) User-side heat exchanger water inlet/outlet temperature 47/55°C (SCOP MT), Average climate profile, with reference to regulation 2013/813 and norm EN 14825.

(3) Energy efficiency class with reference to Regulation 2013/811, conditions in Note 2 (average temperature applications).

ELECTRICAL SPECIFICATIONS

			7.2	8.2	9.2	11.2	14.2	17.2	22.2	27.2
General electrical specifications										
Max. absorbed current (FLA)	(1)	A	30,9	32,2	38,2	50,2	64,6	79,8	94,6	113,7
Rated current (Inom)	(2)	A	26,4	27,5	32,6	42,7	55,3	64	80	95,8
cosφ standard unit	(2)		0,8	0,83	0,82	0,83	0,78	0,88	0,85	0,88
Nominal current with power factor correction (Inom)	(2)	A	21,6	23,1	27,6	36,7	45	58	71,3	97,6
cosφ unit with power factor correction	(2)		0,98	0,98	0,96	0,97	0,96	0,96	0,96	0,96
Max. inrush current (MIC)	(3)	A	110	127	137	165	206	265	319	367
Maximum inrush current with soft-starter (MIC)	(4)	A	72	83	90	109	137	175	211	243
Power supply			400V / 3ph / 50Hz							
Power supply for auxiliary circuits			230-24/1~/50							
Suggested line section	(5)	mm ²	4G10		3x25 + 1G16		3x35 + 1G25		3x50 + 1G25	3x70 + 1G35
Suggested line protection	(6)		NH00gG 50A	NH00gG 50A	NH00gG 63A	NH00gG 80A	NH00gG 100A	NH00gG 100A	NH00gG 125A	NH00gG 160A

- (1) Data regarding the unit without accessories working in maximum power absorption conditions
- (2) Data referring to the basic unit without any accessory operating in standard conditions
- (3) Maximum effective RMS value of the current when the last compressor starts (FLA of the entire unit - FLA of the largest compressor + LRA of the largest compressor)
- (4) Maximum effective RMS value of the current when the last compressor starts (FLA of the entire unit - FLA of the largest compressor + 0.6 x LRA of the largest compressor)
- (5) These values are determined for cables with operating temperature of 40°C, EPR insulation and a line with a maximum length of 50m. The line section must be determined by a qualified technician based on the protection devices, the length of the line, the type of cable used and the type of installation.
- (6) The correct line protection part must be determined by a qualified technician based on the length of the line, the type of cable used and the type of installation.

			14.4	16.4	18.4	23.4	28.4	35.4	43.4	53.4
General electrical specifications										
Max. absorbed current (FLA)	(1)	A	61,8	64,3	76,5	100,3	129,1	159,6	189,2	227,4
Rated current (Inom)	(2)	A	53	55	65	85	111	127	161	192
cosφ standard unit	(2)		0,8	0,83	0,82	0,83	0,78	0,88	0,85	0,88
Nominal current with power factor correction (Inom)	(2)	A	43	46	55	73	90	116	143	175
cosφ unit with power factor correction	(2)		0,97	0,98	0,97	0,97	0,96	0,96	0,96	0,96
Max. inrush current (MIC)	(3)	A	141	159	175	215	271	345	414	481
Maximum inrush current with soft-starter (MIC)	(4)	A	103	115	128	159	201	255	305	357
Power supply			400V / 3ph / 50Hz							
Power supply for auxiliary circuits			230-24/1~/50							
Suggested line section	(5)	mm ²	3x35 + 1G25			3x70 + 1G35	3x95 + 1G50		3x120 + 1G70	2x(3x70) + 1G95
Suggested line protection	(6)		NH00gG 100A	NH00gG 100A	NH00gG 100A	NH00gG 160A	NH1gG 200A	NH1gG 200A	NH1gG 250A	NH2gG 315A

- (1) Data regarding the unit without accessories working in maximum power absorption conditions
- (2) Data referring to the basic unit without any accessory operating in standard conditions
- (3) Maximum effective RMS value of the current when the last compressor starts (FLA of the entire unit - FLA of the largest compressor + LRA of the largest compressor)
- (4) Maximum effective RMS value of the current when the last compressor starts (FLA of the entire unit - FLA of the largest compressor + 0.6 x LRA of the largest compressor)
- (5) These values are determined for cables with operating temperature of 40°C, EPR insulation and a line with a maximum length of 50m. The line section must be determined by a qualified technician based on the protection devices, the length of the line, the type of cable used and the type of installation.
- (6) The correct line protection part must be determined by a qualified technician based on the length of the line, the type of cable used and the type of installation.

HYDRAULIC MODULES

TETRIS W REV OH TB

			7.2	8.2	9.2	11.2	14.2	17.2	22.2	27.2
User-side hydraulic modules										
Standard pumps										
Pump model standard			P2	P2	P2	P5	P5	P9	P10	P12
Available head (1P)	(1)	kPa	215	213	208	191	186	192	223	216
Available head (2P)	(1)	kPa	205	206	199	177	180	182	214	202
Oversize pumps										
Pump model oversized			P3	P3	P3	P6	P6	P10	P11	P13
Available head (1PM)	(1)	kPa	247	245	241	244	239	236	299	275
Available head (2PM)	(1)	kPa	238	239	232	229	232	225	290	261
Source-side hydraulic modules										
Standard pumps										
Pump model standard			P1	P1	P1	P4	P5	P5	P9	P10
Available head (1S)	(1)	kPa	162	157	146	148	169	149	158	174
Available head (2S)	(1)	kPa	147	147	131	124	157	130	141	150
Oversize pumps										
Pump model oversized			P2	P2	P2	P5	P7	P10	P10	P11
Available head (1SM)	(1)	kPa	211	206	194	186	227	222	202	253
Available head (2SM)	(1)	kPa	197	196	179	161	214	204	185	229

TETRIS W REV OH TB

			14.4	16.4	18.4	23.4	28.4	35.4	43.4	53.4
User-side hydraulic modules										
Standard pumps										
Pump model standard			P9	P9	P9	P10	P12	P12	P14	P15
Available head (1P)	(1)	kPa	211	206	199	227	225	210	214	233
Available head (2P)	(1)	kPa	204	197	187	216	217	208	210	227
Oversize pumps										
Pump model oversized			P10	P10	P10	P11	P13	P13	P15	P17
Available head (1PM)	(1)	kPa	256	250	243	303	283	266	250	289
Available head (2PM)	(1)	kPa	249	241	230	293	275	264	246	283
Source-side hydraulic modules										
Standard pumps										
Pump model standard			P8	P8	P9	P9	P10	P12	P12	P14
Available head (1S)	(1)	kPa	135	128	179	153	165	179	151	160
Available head (2S)	(1)	kPa	123	112	157	134	143	159	147	151
Oversize pumps										
Pump model oversized			P9	P9	P10	P10	P11	P13	P13	P16
Available head (1SM)	(1)	kPa	197	192	222	198	244	234	205	200
Available head (2SM)	(1)	kPa	185	176	200	179	222	215	201	191

(1) Source exchanger inlet-outlet water temperature 45/40 ° C; user exchanger inlet-outlet water temperature 70/78 ° C. Values compliant with standard EN 14511

	Rated power	Rated current	Min. flow rate	Max. flow rate
	kW	A	m ³ /h	m ³ /h
P1	1,1	2,45	7,2	18,1
P2	1,5	3,15	7,2	18,1
P3	2,2	4,24	7,2	18,1
P4	1,5	3,43	12	25,8
P5	2,2	4,5	12	31,2
P6	3	6,24	12	31,2
P7	2,2	4,25	6	20
P8	1,5	3,2	12	42
P9	2,2	4,5	12	42
P10	3	6,1	12	42
P11	4	8,7	12	42
P12	4	8,7	24	72
P13	5,5	10,4	24	72
P14	5,5	10,4	42	126
P15	7,5	13,6	42	132
P16	7,5	13,6	42	126
P17	9,2	17,2	42	132

USER-SIDE EXCHANGER FLOW RATE FIELDS

The units are sized and optimized for the following nominal conditions:

- source exchanger inlet-outlet 45/40 ° C
- user exchanger inlet-outlet 70/78 ° C

The units can work at design conditions different from nominal conditions, provided that:

- the design condition falls within the operating limits specified below
- the unit is equipped with all the accessories necessary for operation of the unit (e.g. brine kit, condensation control)
- the flow rate at design conditions (that is, of the specific application) must always come within the allowed flow rate ranges specified below. If the design conditions require a water flow rate that does not come within the allowed operating range, you must contact our sales department that will identify the most suitable solution for the specific application.

TETRIS W REV OH TB

	User-side heat exchanger		Source-side heat exchanger	
	Qmin	Qmax	Qmin	Qmax
	m ³ /h	m ³ /h	m ³ /h	m ³ /h
7.2	4,4	14,9	5,5	13,3
8.2	5	17	6,3	15,2
9.2	5,8	19,7	6,3	17,7
11.2	6,3	24,5	7,8	21,8
14.2	7,5	29,4	8,2	26
17.2	9,5	37,2	10,4	32,9
22.2	11,9	46,5	13	41,2
27.2	14,7	57,3	16,2	50,6
14.4	10,6	29,8	11	26,6
16.4	12	33,9	12,3	30,5
18.4	13,9	39,4	13,7	35,4
23.4	17,4	49	15,9	43,5
28.4	20,7	58,8	16	52
35.4	23,2	74,5	18,4	65,9
43.4	26,9	93	23,1	82,5
53.4	33,3	114,6	28,7	101,1

OPERATING LIMITS

TETRIS W REV OH TB

HEATING

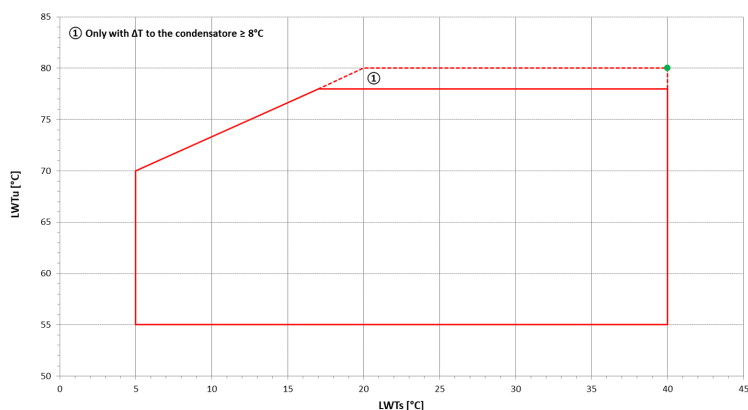

LWTs: water outlet temperature from the source-side heat exchanger

LWTu: water outlet temperature from the user-side heat exchanger

The inlet and outlet temperatures of the user-side exchanger must be given on ordering to allow correct setting of the alarm parameters and verification of the sizing of the expansion valve.

The unit will be optimized to operate at the set point temperatures communicated to the order. For different set points, the thermal power supplied and the efficiency level of the machine could decrease as you move away from these conditions.

INSTALLATION ADVICE

The units described in this document are, by nature, strongly affected by the characteristics of the system, the working conditions and the installation site.

Remember that the unit must be installed by a qualified and skilled technician, and in compliance with the national legislation in force in the destination country.

The installation must be done in such a way that it will be possible to carry out all routine and non-routine maintenance operations.

Before starting any work, you must carefully read the "Installation, operation and maintenance manual" of the machine and do the necessary safety checks to prevent any malfunctioning or hazards.

We give some advice below that will allow you to increase the efficiency and reliability of the unit and therefore of the system into which it is inserted.

Water characteristics

To preserve the life of the exchangers, the water is required to comply with some quality parameters and it is therefore necessary to make sure its values fall within the ranges indicated in the following table:

Total hardness	2,0 ÷ 6,0 °f
Langelier index	- 0,4 ÷ 0,4
pH	7,5 ÷ 8,5
Electrical conductivity	10 ÷ 500 µS/cm
Organic elements	-
Hydrogen carbonate (HCO₃⁻)	70 ÷ 300 ppm
Sulphates (SO₄²⁻)	< 50 ppm
Hydrogen carbonate / Sulphates (HCO₃⁻/SO₄²⁻)	> 1
Chlorides (Cl⁻)	< 50 ppm
Nitrates (NO₃⁻)	< 50 ppm
Hydrogen sulphide (H₂S)	< 0,05 ppm
Ammonia (NH₃)	< 0,05 ppm
Sulphites (SO₃), free chlorine (Cl₂)	< 1 ppm
Carbon dioxide (CO₂)	< 5 ppm
Metal cations	< 0,2 ppm
Manganese ions (Mn⁺⁺)	< 0,2 ppm
Iron ions (Fe²⁺ , Fe³⁺)	< 0,2 ppm
Iron + Manganese	< 0,4 ppm
Phosphates (PO₄³⁻)	< 2 ppm
Oxygen	< 0,1 ppm

Installation of water filters on all the hydraulic circuits is obligatory.

The supply of the most suitable filters for the unit can be requested as accessory. In this case, the filters are supplied loose and must be installed by the customer following the instructions given in the installation, operation and maintenance manual.

Glycol mixtures

With temperatures below 5°C, it is mandatory to work with water and anti-freeze mixtures, and also change the safety devices (anti-freeze, etc.), which must be carried out by qualified authorised personnel or by the manufacturer.

Liquid outlet temperature or minimum ambient temperature	°C	0	-5	-10	-15	-20	-25	-30	-35	-40
Freezing point	°C	-5	-10	-15	-20	-25	-30	-35	-40	-45
Ethylene glycol	%	6	22	30	36	41	46	50	53	56
Propylene glycol	%	15	25	33	39	44	48	51	54	57

The quantity of antifreeze should be considered as % on weight

Minimum water content in the system

For correct operation of the unit, it is necessary to ensure a buffering on the system such as to comply with the minimum operating time considering the greater between the minimum OFF time and the minimum ON time. In short, these contribute to limiting the number of times the compressors are switched on per hour and to preventing undesired deviations from the set point of the delivered water temperature.

The following experimental formula allows to calculate the minimum water volume of the plant.

$$V_{min} = \frac{P_{tot} \cdot 1000}{N} \cdot \frac{180}{\Delta T \rho C_p} + P_{tot} \cdot 0.25$$

where

V_{min} is the minimum water content of the system [l]

P_{tot} is the total cooling capacity of the machine [kW]

N : number of capacity reduction steps

ΔT : differential allowed on the water temperature. Unless otherwise specified, this value is considered to be 2.5K

ρ : density of the heat-carrying fluid. Unless otherwise specified, the density of water is considered

c_p : specific heat of the heat-carrying fluid. Unless otherwise specified, the specific heat of water is considered

Considering the use of water and grouping together some terms, the formula can be re-written as follows:

$$V_{min} = \frac{P_{tot}}{N} \cdot 17,2 + P_{tot} \cdot 0,25$$

N is equal to the number of compressors installed in the unit.

Larger amounts of water are in any case always preferable, because they allow a smaller number of starts and switch-offs of the compressors, less wear of them and an increase in the efficiency of the system as a consequence of a reduction in the number of transients.

Installation site

To determine the best installation site for the unit and its orientation, you should pay attention to the following points:

- compliance with the clearance spaces indicated in the official dimensional drawing of the unit must be guaranteed so as to ensure accessibility for routine and non-routine maintenance operations
- you should consider the origin of the hydraulic pipes and their diameters because these affect the radiuses of curvature and therefore the spaces needed for installing them
- you should consider the position of the cable inlet on the electrical control panel of the unit as regards the origin of the power supply
- if the installation includes several units side by side, you should consider the position and dimensions of the manifolds of the user-side exchangers and of any recovery exchangers
- if the installation includes several units side by side, you should consider that the minimum distance between units is 3 metres
- you should avoid all obstructions that can limit air circulation to the source-side exchanger or that can cause recirculation between air supply and intake
- you should consider the orientation of the unit to limit, as far as possible, exposure of the source-side exchanger to solar radiation
- if the installation area is particularly windy, the orientation and positioning of the unit must be such as to avoid air recirculation on the coils. If necessary, we advise making windbreak barriers in order to prevent malfunctioning.

Once the best position for the unit has been identified, you must check that the support slab has the following characteristics:

- its dimensions must be proportionate to those of the unit: if possible, longer and wider than the unit by at least 30 cm and 15/20cm higher than the surrounding surface
- it must be able to bear at least 4 times the operating weight of the unit
- it must allow level installation of the unit: although the unit is installed on a horizontal base, make slopes in the support surface to convey rain water or defrost water to drains, wells or in any case to places where it cannot generate an accident hazard due to ice formation. All heat pump version units are equipped with discharge manifolds for the condensed water; these can be manifolded to facilitate condensate discharge.

The units are designed and built to reduce to a minimum the level of vibration transmitted to the ground, but it is in any case advisable to use rubber or spring anti-vibration mounts, which are available as accessory and should be requested when ordering.

The anti-vibration mounts must be fixed on before positioning the unit on the ground.

In the event of installation on roofs or intermediate floors, the pipes must be isolated from the walls and ceilings.

It is advisable to avoid installation in cramped places, to prevent reverberations, reflections, resonances and acoustic interactions with elements outside the unit.

It is essential that any work done to soundproof the unit does not affect its correct installation or correct operation and, in particular, does not reduce the air flow rate to the source-side exchanger.

Swegon Operations s.r.l.

Via Valletta, 5 - 30010

Cantarana di Cona, (VE) Italy - T. +39 0426 921111 - F. +39 0426 302222

www.blueboxcooling.com - info@bluebox.it



Swegon Operations s.r.l. a socio unico - P.IVA 02481290282

Company directed and coordinated by Investment Latour (Sweden)