

Tau Sky Hi HP

6÷19 kW



General

Reversible heat pump for residential applications
Hermetic inverter-controlled BLDC compressor
Monoblock unit, compact and easy to install
Heating capacity range from 6 to 19 kW, five sizes available

Configurations

HP: reversible heat pump version

Strengths

- ▶ Unit "hermetically sealed" according to EN 60335-2-40
- ▶ Advanced control thanks to built-in WiFi connectivity Two temperature levels managed (opt)

Strengths

- ▶ Refrigerant R32: solution with very low environmental impact (GWP=675)
- ▶ This unit is designed to achieve the lowest noise emission levels in its category.
- ▶ Components (compressor, fan, circulator) include DC motors for max. efficiency, both in full load conditions and in modulation mode.
- ▶ Domestic hot water control
- ▶ Standard anti-corrosion treatment
- ▶ Extended envelope: LWT up to 58°C with external temperatures down to -15°C
- ▶ Easy to install, compact in size

BlueBox 
by Swegon

TAU SKY Hi HP	
Other accessories	10
Technical specifications	11
Ecodesign	12
Electrical specifications	16
User-side exchanger flow rate fields	17
Operating limits	18
TAU SKY Hi HP	18
Noise levels	19
Installation advice	20
Water characteristics	20
Glycol mixtures	20
Minimum water content in the system	21
Installation site	22



EFFICIENCY IS SYNONYMOUS WITH INVERTER

The global push to increase the energy efficiency of buildings and systems is driving the development of all technologies that can make a contribution.

In the HVAC sector, this is realized in the development of technologies that enable the maximum energy saving to be obtained in partial load conditions.

The technology that, more than any other technology, enables considerable efficiency improvements in operation at partial loads is inverter technology applied to compressors. This allows the maximum efficiency to be obtained while maintaining the same operating limits of conventional units.

The more variable the load (as in comfort applications), or the longer the operating cycle where source temperatures are variable (as for combined air-water units in industrial applications), the stronger this advantage becomes.

The need to comply with the energy efficiency targets set by environmentally friendly design will increasingly push the adoption of units equipped with this technology.

Tau Sky Hi HP

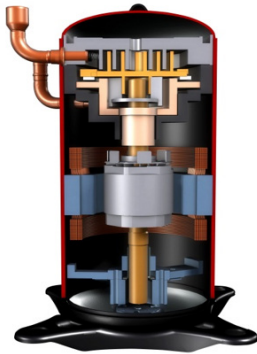

Units until size 12 are fitted with a hermetic DC inverter-controlled rotary compressor featuring a brushless motor. Unit sizes 15 and 19 are fitted with a scroll DC inverter-controlled rotary compressor featuring a brushless motor.

In comparison to a compressor with asynchronous motor, a compressor with brushless motor (BLDC motor or PMDC motor) has a rotor containing permanent magnets. These make it intrinsically more efficient thanks to the magnetization energy saving of the rotor and to the fact that there are no rubbing parts.

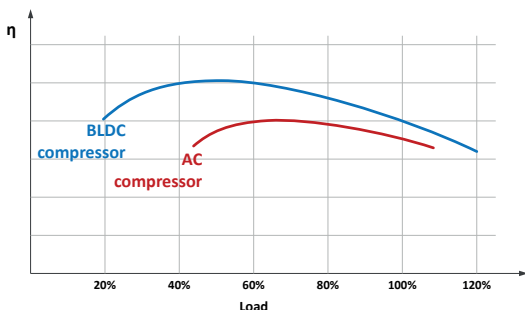

As can be seen in the diagram, a brushless motor is more efficient than a normal asynchronous motor and its efficiency reaches its maximum when the compressor is working under partial load conditions.

It can also be seen that, since it is specially built to also operate at low speeds, a BLDC compressor has a wider speed adjustment range than a conventional compressor controlled through an AC inverter.

Il compressore BLDC non può essere alimentato direttamente, ma deve essere pilotato attraverso un inverter DC che si occupa della gestione delle rampe di accelerazione e di rallentamento, della gestione del suo avviamento senza spunti e di garantire che il compressore operi sempre in condizioni di sicurezza e stando all'interno dei limiti operativi ammessi. This is essential to preserve the efficiency and reliability of the compressor.

Management of a variable capacity machine

In addition to the advantage of greater efficiency, the use of a modulating compressor allows the unit to adapt its cooling capacity to the actual heat load to be met.

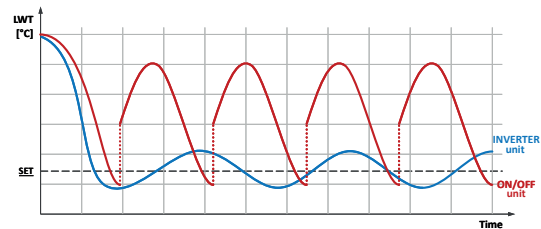

Normally, the capacity supplied by the unit exceeds the capacity actually required by the system.

In this condition, a machine with ON/OFF compressors will go through a sequence of ON and OFF cycles in an attempt to keep the water temperature within a set differential.

At each subsequent restart, the refrigerant circuit must find the best balance condition and this phase requires a time that ranges from 1 to 3 minutes during which the unit undergoes irreversible energy losses and has a very low energy efficiency.

In a different way, a machine with inverter-controlled compressor will be able to modulate its cooling capacity and adapt to the load.

The unit controller checks the output water temperature and its variation over time in order to determine the capacity level required by the system and to set the compressor speed accordingly. To do so, the controller outputs a serial signal to induce the inverter to modulate the compressor frequency with a view to eventually modulating its speed and the unit performance as a result.

The further away the water outlet temperature is from the set point, the greater the capacity that will be required by the controller. As the outlet temperature approaches the set point temperature, the controller will slow down the compressor and limit temperature oscillation as much as possible.

In this way, as far as possible, the controller keeps the compressor always running in modulating mode, thereby avoiding the irreversible energy losses of the starts and exploiting the condition in which the brushless compressor works with its maximum efficiency.

TAU SKY Hi HP

Tau Sky Hi HP is a reversible heat pump for outdoor installation, designed for the production of hot and cold water, as well as domestic hot water. The unit consists of an outdoor unit (coil, fans, compressor, inverter, plate heat exchanger, circulator) and an indoor unit (controller board, display).

More specifically, the unit has the following features:

- very low noise levels for optimised environmental comfort;
- inverter-controlled DC brushless compressor;
- very low GWP refrigerant R32;
- single circuit configuration;
- finned coil with copper tubes and aluminium fins;
- user-side heat exchanger made of brazed steel.

The unit is supplied with an electronic expansion valve, a flow switch and a circulator that are built in the machine.

Tau Sky Hi HP is a reliable and versatile unit and it modulates the supplied charge by means of an accurate temperature control, combined with the inverter technology for maximised performances both at full and part load.

Special attention is given to performances during winter operation. The inverter technology offers greater operating ranges and performances if compared with traditional technology, thus ensuring min. energy consumption and the possibility to produce water at 45°C with external temperatures down to -25°C.

The possibility to select two different types of controller (standard or advanced) helps fulfil the range of functions required by the end user in the most effective way possible.

STRUCTURE

The frame is made of galvanized sheet-iron coated with polyester powder, which makes it highly resistant to weather conditions. The frame is load-bearing type and it has removable panels for total access to the internal components. The cover of the unit is made of stainless steel. All screws and bolts are painted or made of stainless steel. The panels can be removed easily to allow full access to internal components.

The compressor is coated with heat- and noise-insulating material and the panels in the compressor compartment and the roof of the unit are internally insulated with heat- and noise-insulating material. This insulation contributes to achieving min. noise levels, which makes Tau Sky Hi HP one of the lowest noise machines on the market.

HERMETICALLY SEALED PRODUCT

TAU SKY Hi HP is cataloged as hermetically sealed equipment according to the EN 60335-2-40 standard, this means that its installation can be carried out directly by the plumber without the need for an F-GAS license.

REFRIGERANT

Standard refrigerant R32

R32 is distinguished by its low environmental impact, with GWP=675*. It is also a non-toxic fluid: A2-L classification under ASHRAE; Category 2 under EN 378.

These characteristics facilitate the adoption of the model in the presence of any specific local requirements related to the environmental impact caused by the refrigerants. This has positive effects on transport, operation and maintenance and also on overall cost effectiveness, as regards possible taxation or restrictions on the use of refrigerants with high environmental impact.

(*) GWP (AR5), pursuant to IPCC V, evaluated over a span of 100 years.

COMPRESSORS

The compressor is brushless powered by direct current (BLDC) with a permanent magnet motor, driven by an inverter and integrated crankcase heater. Brushless technology and inverter frequency control contribute to long compressor service life and to operating reliability over time. No rubbing elements being present and continuous charge capacity reduction help the compressor keep its structural integrity, prevent frequent stops and keep the operating speed at minimum, which results in significant energy saving.

SOURCE-SIDE HEAT EXCHANGER

The exchangers on the user side are made with finned pack coils featuring copper tubes and aluminium fins.

An electric heater is fitted on the base of each finned coil to prevent water in the condensate drip tray from freezing and an antifreeze heater is mounted on the plate heat exchanger. These heaters enable unit operation even at very low temperatures and with very high humidity levels. The finned coil is installed as standard including suitable hydrophilic treatments for easier condensed water drainage from the coil.

USER-SIDE HEAT EXCHANGER

The exchanger is a braze-welded stainless steel plate heat exchanger, insulated with a shroud of closed-cell insulating material.

The exchanger is also equipped with thermostat-controlled anti-freeze heater to protect it from ice formation when the unit is not running.

When the unit is in operation, a flow switch (installed as standard) causes the unit to stop and thus protects the heat exchangers whenever the flow rate is missing.

FANS

The fans are axial type directly coupled to an 8-pole permanent magnet direct current electric motor (brushless DC) with integrated thermal protection and IP 54 protection degree.

REFRIGERANT CIRCUIT

The compressor is coated with heat- and noise-insulating material and the panels in the compressor compartment and the roof of the unit are internally insulated with heat- and noise-insulating material. The delivery and intake lines, the fluid receiver, the plate heat exchanger and the pipes used for the hydraulic connections are heat insulated.

Each refrigerant circuit comprises:

- 4-way valve
- charging valves
- electronic expansion valve
- high pressure switch

ELECTRICAL CONTROL PANEL (INTERNAL UNIT)

The electrical control panel consists of a painted and galvanized sheet-iron box with IP34 protection rating.

The electrical control panel hosting the standard controller includes:

- a base display;
- a PCB (controller board);
- 2 power contacts: electric heaters and pump in zone 1. Contacts are such that they can power circulators up to 300 W.
- trasformatore per alimentare la scheda di controllo
- remote ON/OFF contact
- summer/winter switch contact
- power supply and signal to diverter valve for (cooling or heating) system/domestic hot water and to mixing valve on system side, zone 1

The electrical control panel hosting the advanced controller includes:

- touch screen display;
- a PCB (controller board);
- 3 power contacts: electric heaters, pump in zone 1 and pump in zone 2. Contacts are such that they can power circulators up to 300 W.
- trasformatore per alimentare la scheda di controllo
- remote ON/OFF contact
- summer/winter switch contact
- modulo per connettività Wi-Fi
- power supply and signal to diverter valve for (cooling or heating) system/domestic hot water and to mixing valves on system side, zone 1 and zone 2

During the installation phase it must be considered that the connection cable between the indoor and outdoor units and the sensors have a standard length of 10 meters. To evaluate the possibility of an extension consult the installation, use and maintenance manual.

The connections to be made between the indoor and outdoor units are to be made for: probes, flow switch, serial communication, pump and antifreeze. The power supply cables for the pump and antifreeze heater are the responsibility of the installer / customer.

CONTROL

The unit is supplied as standard with a standard controller. The advanced control can be requested as accessory.

Main controller functions standard

The standard controller has a semi-graphic display with 6 buttons, as shown in the figure below.



The control allows the following functions:

- Setup of temperature setpoint using a preset climate curve (heating only)

If the unit is set for operation in automatic mode, the controller will set the working setpoint according to a predefined climate curve.

When in heating mode, the lower the external air temperature, the higher the water temperature setpoint.

The purpose of this function is, on the one hand, to optimise the unit efficiency to prevent the production of water that is too hot when it is not needed and, on the other, to help the unit respond to variations in the external air temperature efficiently. If the temperature of the output water fails to meet the user requirements, the parameters of the climate curve can be shifted in compliance with specific requirements.

Below is an example of climate curve.

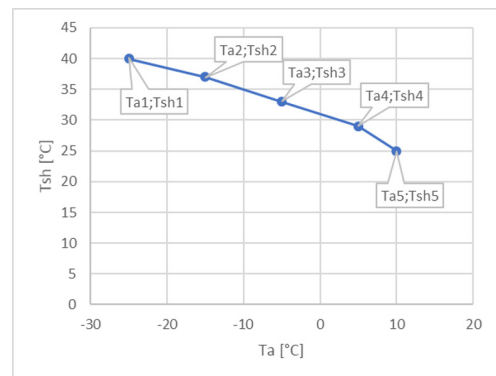

If the unit is controlled according to ambient temperature and its effect on the heating curve is enabled, the unit will change the water temperature setpoint in heating mode at fixed time intervals, based on the difference between the external air temperature measured and the relevant setpoint. The resulting difference is then subtracted from the water temperature setpoint that has been calculated according to the climate curve.

- Managing a supplementary system to domestic hot water production
- Managing of a secondary heating/cooling system (i.e. traditional boiler, etc.)

The diagram below shows a system with one temperature level.

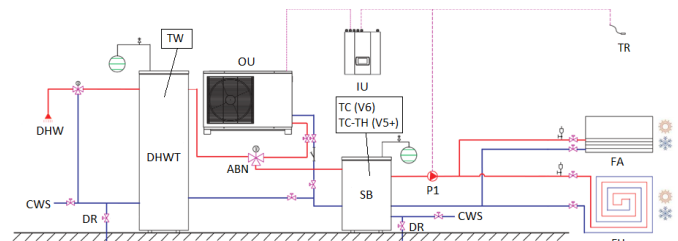

Key:

- OU: outdoor unit
- IU: indoor unit
- SB: DHW buffer tank
- DHWT: domestic hot water tank
- DHW: domestic hot water
- P1 : User-side circulator
- RTP: ambient temperature probe
- FA: Fancoil
- FH: floor heating
- CWS: cold water supply
- DR: water drain

If the system is requesting domestic hot water, the controller changes the position of the 3-way valve in order to feed the tank used to store domestic hot water and to reset the stored temperature setpoint. Priority is always given to the production of domestic hot water (DHW). As soon as the demand for DHW is met, the unit switches back to the production of either hot or cold water, depending on the specific case.

As it controls a water valve fitted with a modulating servo motor, the controller can supply water for different applications: traditional radiator system (RA), fan coil system (FC) and floor heating systems (FH).

- Anti-legionella cycle management procedure

A set of parameters can be set up using the controller in order to automatically enable the anti-legionella function in a predefined time span. The controller can also be used to preset the temperature at which water is to be heated in the domestic hot water tank together with the min. and max. cycle time. As the max. temperature of domestic hot water produced by the unit is 55°C, the electric heaters installed in the domestic hot water tank contribute to providing the heating capacity required to achieve the optimal temperature to implement the anti-legionella function.

- Time band programming

The unit can be controlled according to time bands (time thermostat). This has two implications: the unit may be switched on and off at a predefined time and ancillary functions (shower function, anti-legionella cycle, function to prevent pump stops) may be enabled.

- Low noise mode

Thanks to time band management the controller can reduce the noise levels in predefined daily intervals of time by exerting a direct action on the compressor frequency and on the rotation speed of the fans.

For additional information on the available functions and the machine setup, please refer to the specific controller manual.

Main controller functions advanced

As an alternative to the standard controller, this range can be controlled by a programmable microprocessor controller featuring a user interface that comes in the form of an advanced touch screen control panel. WiFi connection as standard

The advanced controller has a touch screen display, as shown in the figure below.



In addition to the functions featured in the standard controller, the advanced controller is also used for the following:

- Setup of temperature setpoint using a preset climate curve (**heating and cooling**)

If the unit is set for operation in automatic mode, the controller will set the working setpoint according to the distance of the output water temperature from its setpoint, as specified by a predefined climate curve in the controller.

When in heating mode, the lower the external air temperature, the higher the water temperature setpoint.

When in cooling mode, the higher the external air temperature, the lower the water temperature setpoint.

The purpose of this function is, on the one hand, to optimise the unit efficiency to prevent the production of water that is too hot when it is not needed and, on the other, to help the unit respond to variations in the external air temperature efficiently. If the temperature of the output water fails to meet the user requirements, the parameters of the climate curve can be shifted in compliance with specific requirements.

Below is an example of climate curve in both heating and cooling mode, with reference to two different temperature zones.

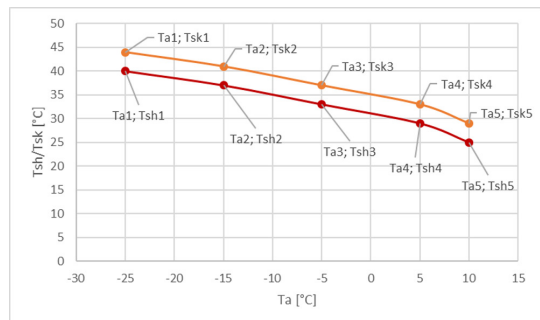

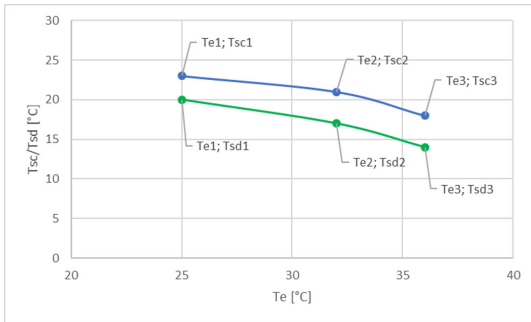

If the unit is controlled according to ambient temperature and its effect on the heating or cooling curve is enabled, the unit changes the water temperature setpoint in either heating or cooling mode at fixed time intervals, based on the difference between the external air temperature measured and the relevant setpoint. The resulting difference is then subtracted from the water temperature setpoint that has been calculated according to the climate curve.

- Alarm history logging
 - Multi-zone management including control of two temperature levels
- The diagram below shows a system with two temperature levels.

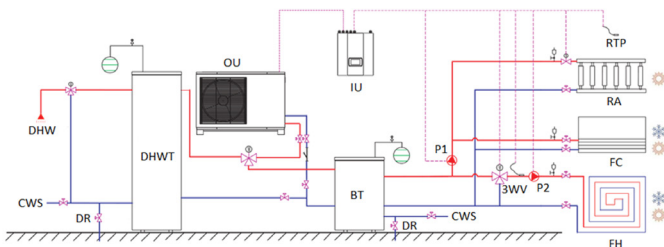

Key:

- OU: outdoor unit
- IU: indoor unit
- SB: DHW buffer tank
- P1 , P2 : User-side circulators
- RTP: ambient temperature probe
- RA: traditional radiator
- FC: fan coil
- FH: floor heating
- 3WV: 3-way diverter valve
- CWS: cold water supply
- DR: water drain

Based on the setting the user wishes to use, the unit can output a heating capacity that may either be dependant on a fixed temperature setpoint or be variable according to the external air temperature. The purpose of this is to maximise the system efficiency by either increasing or reducing the water temperature to the user.

If the system is requesting domestic hot water, the controller changes the position of the 3-way valve in order to feed hot water to the domestic hot water tank and to reset the stored temperature setpoint. Priority is always given to the production of domestic hot water (DHW). As soon as the demand for DHW is met, the unit switches back to the production of either hot or cold water, depending on the specific case.

A 3-way valve with ON/OFF control and two 3-way diverter valves with modulating control enable the controller to manage domestic hot water and to control the water supply up to 2 zones in which a traditional radiator system (RA), a fan coil system (FC) or a heating floor system (FH) is installed.

- External source integration (ON/OFF)

When the external air temperature is below a predefined level, the controller can manage (ON/OFF) an auxiliary heating system in order to reduce the work load on the heat pump only and to increase the level of system efficiency. Large differences between the temperature and pressure levels at which condensation and evaporation occur result in low operating efficiency levels. This helps achieve the desired temperature level of the water delivered to the user or domestic hot water even in cases when a very strong temperature drop is experienced and this cannot not be tackled by the pump alone.
- DHW ECO operation

If the external air temperature drops below a preset value, a supplementary external system is engaged to heat the water stored in the domestic hot water tank. The compressors in the unit stop when this function is enabled.
- DHW tank

This function is designed to set up the specific time bands during which the unit heats the water filled in the domestic hot water tank. This helps achieve the desired temperature when required.
- Holiday mode

Holiday mode is designed to reduce the temperature setpoints of water filled in the domestic hot water tank and the temperature of water delivered to the system in cases when the facility is uninhabited for a long time. This mode helps energy saving and, at the same time, it contributes to reducing the temperature to the min. level required to prevent stressful compressor restarts.

For additional information on the available functions and the machine setup, please refer to the specific controller manual.

CONTROLS AND SAFETY DEVICES

All the units are fitted with the following control and safety components:

- user-side water temperature probe
- antifreeze probe on the user side heat exchanger
- high pressure switch with automatic reset
- low pressure safety device with automatic reset, for a limited number of occurrences, managed by the controller
- compressor overtemperature protection
- fan overtemperature protection
- mechanical paddle flow switch

TRANSPORT

Units must not be shipped by air freight.

Other accessories

AG Rubber anti-vibration mounts

These allow you to reduce the vibrations transmitted from the unit to the surface it is standing on. Accessory supplied loose.

TB Base frame

The base frame is needed to install the unit at a min. height from ground level. This option is strongly recommended in snowy areas where the air flow through the coil may be obstructed by the surrounding snow. The frame is supplied with rubber anti-vibration mounts.

Accessory supplied loose.

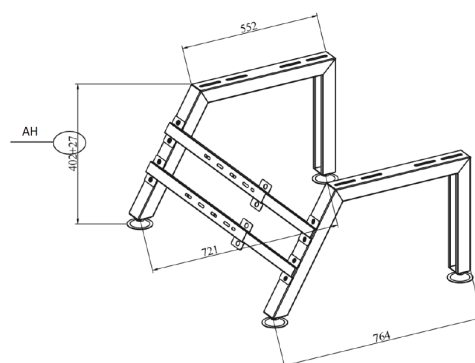
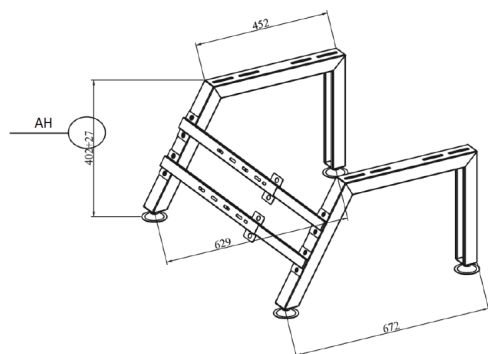

CA55 IP55 electric box for basic / advanced control

The accessory consists of an electrical box in additional galvanized sheet metal with IP55 protection grade with 6 cable glands in the lower part for the cable outlets, door lock, equipped with fan and grille for cooling in summer and heating resistance for heating during winter. The installation of the Basic or Advanced Control Panel inside the box is recommended for installation of the Panel in an external and unprotected environment. The box is shipped empty and the installation is care of the customer / installer. For the appropriate installation procedures, refer to the installation and maintenance manual.



TECHNICAL SPECIFICATIONS

TAU SKY HI HP

			6	9	12	15	19
Cooling							
Refrigeration capacity	(1)	kW	5,4	6,8	7,1	13,7	17,5
Total absorbed power	(1)	kW	1,6	1,9	2,1	4,5	5,6
EER	(1)		3,34	3,55	3,37	3,02	3,11
Eurovent efficiency class	(1)		A	A	A	B	A
Heating							
Heating capacity	(2)	kW	6,5	9,2	11,6	15,3	18,5
Total absorbed power	(2)	kW	1,4	2,1	2,6	3,2	4,1
COP	(2)		4,7	4,46	4,39	4,81	4,5
Eurovent efficiency class	(2)		A	A	A	A	A
Compressors							
Compressors/Circuits		n°/n°	1/1	1/1	1/1	1/1	1/1
Minimum capacity reduction step	(6)	%	33%	33%	33%	33%	33%
Refrigerant charge	(3)	kg	0,9	1,4	1,8	2,55	3,3
User-side heat exchanger							
Quantity		n°	1	1	1	1	1
Water flow rate	(2)	m³/h	1,1	1,6	2	2,6	3,2
Fans							
Quantity		n°	1	1	1	2	2
Total air flow rate		m³/h	2500	3150	3150	3100	3500
Hydraulic modules							
Available head (1P)		kPa	64	59	49	29	25
Nominal water flow rate		m³/h	1,1	1,6	2	2,6	3,2
Rated power		kW	0,087	0,087	0,087	0,087	0,087
Rated current		A	0,66	0,66	0,66	0,66	0,66
Max. absorbed power		kW	0,087	0,087	0,087	0,087	0,087
Max. absorbed current		A	0,66	0,66	0,66	0,66	0,66
Noise levels							
Sound power lev.	(4)	dB(A)	52	53	52	58	61
Sound pressure lev.	(5)	dB(A)	21	22	21	27	30
Dimensions and weights**							
Length		mm	1010	1165	1165	1085	1085
Depth		mm	370	370	370	390	390
Height		mm	700	845	845	1450	1450
Operating weight		kg	67	80	85	120	140

(1) External air temperature of 35°C and user-side heat exchanger water inlet-outlet temperature of 12-7°C. Values compliant with standard EN 14511

(2) Outside air temperature 7°C DB, 6°C WB; condenser inlet/outlet water temperature 30/35°C. Values compliant with standard EN 14511

(3) Theoretical values referred to the basic unit. The amount of gas actually charged in the unit may differ.

(4) Unit operating at rated capacity, with no accessories of any kind - external air temperature 7°C and water input/output temperature from/to heat exchanger and user equal to 30/35°C. Values taken by measurements made in accordance with standard ISO 3744 and the Eurovent certification programme, where applicable. Binding values See NOISE LEVELS section.

(5) Values obtained from the sound power level (conditions: note 4), related to a distance of 10 m from the unit in free field with directivity factor Q=2. Non-binding values See NOISE LEVELS section.

(6) Approximate value. The minimum capacity reached by the unit depends on the operating conditions. The value shown may not be suitable for calculating the minimum volume of water: to do this, consult the "Minimum water content in the system" section.

** Basic unit without included accessories

The certified standard performances and data can be verified in <https://www.eurovent-certification.com>

Some voluntary data are not certified (i.e. Noise Level for water source units; SCOP for units with Pdesign >70 KW; SCOP MT values).

ECODESIGN

INTRODUCTION

The Ecodesign/ErP Directive (2009/125/EC) lays down new standards for more efficient energy use.

The Directive contains various regulations; as regards chiller products and heat pumps, the regulations of interest are the following:

- Regulation 2013/813, for small heat pumps ($P_{\text{design}} \leq 400$ kW)
- Regulation 2016/2281, for chillers and heat pumps with $P_{\text{design}} > 400$ kW
- Regulation 2013/811, for heat pumps with $P_{\text{design}} \leq 70$ kW.

The last-mentioned regulation (2013/811) regards the labelling (Ecolabel certification) of small heat pumps.

The other two regulations (2013/813 and 2016/2281) set seasonal efficiency targets that the products must comply with to be sold and installed in the European Union (essential requirement for CE marking).

These efficiency limits are defined through ratios, which are respectively:

- η_{sh} (SCOP), with reference to regulation 2013/813
- η_{sc} (SEER) for comfort applications and SEPR for process applications, with reference to regulation 2016/2281.

The figure below schematically illustrates the correspondence between product and reference energy ratio.

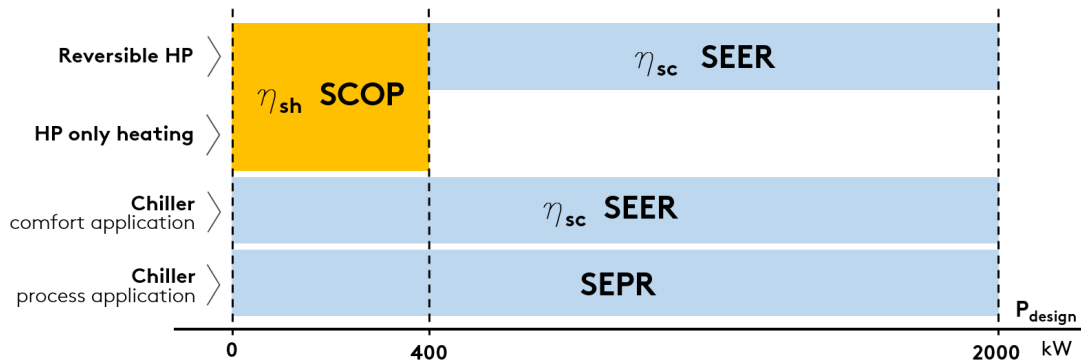

Some notes and clarifications:

For comfort applications, regulation 2016/2281 sets the η_{sc} (SEER) ratio in two different operating conditions:

- SEER calculated with machine inlet/outlet water temperature of 12/7°C (low temperature application),
- SEER calculated with machine inlet/outlet water temperature of 23/18°C (medium temperature application).

The minimum efficiency requirement is the same, but can be met at condition 12/7°C or at condition 23/18°C, depending on the application envisaged for the machine.

Regulation 2013/813 distinguishes two different types: at low temperature and at medium temperature.

The following refer to the application at low temperature: (low temperature application) all heat pumps whose maximum delivery temperature for heating purposes is lower than 52°C with source at temperature of -7°C and -8°C wet bulb (air-water unit) or inlet 10°C (water-water unit), at the reference design conditions for an average climate. For these, the efficiency ratio is "low temperature application" (outlet water temperature 35°C).

For all the other heat pumps, the efficiency ratio is related to "medium temperature application" (outlet water temperature 55°C).

The ratios must be calculated according to the reference European heating season in average climatic conditions.

The minimum efficiency requirements set by the regulations are indicated below.

REGULATION 2016/2281, comfort application

TYPE OF UNIT		MINIMUM REQUIREMENT	
SOURCE	P _{design}	η_{sc} [%]	SEER
air	< 400 kW	161	4,1
air	\geq 400 kW	179	4,55
water	< 400 kW	200	5,075
water	\geq 400 kW and < 1500 kW	252	6,375
water	\geq 1500 kW	272	6,875

REGULATION 2016/2281, process application

TYPE OF UNIT		MINIMUM REQUIREMENT
SOURCE	P _{design}	SEPR
air	< 400 kW	5
air	\geq 400 kW	5,5
water	< 400 kW	7
water	\geq 400 kW and < 1500 kW	8
water	\geq 1500 kW	8,5

REGULATION 2013/813

SOURCE	APPLICATION	MINIMUM REQUIREMENT	
		η_{sh} [%]	SCOP
air	low temperature application	125	3,2
water	low temperature application	125	3,325
air	medium temperature application	110	2,825
water	medium temperature application	110	2,95

The conformity of the product must be checked according to the type of application, whether comfort or process, and at the required outlet water temperature.

The two schematic tables below, respectively for comfort application and for process application, indicate the reference of the required conformity according to the type of product and the set point temperature (reference to regulations 2016/2281 and 2013/813).

Important note: for mixed comfort and process applications, the reference application for conformity is the comfort application.

COMFORT APPLICATION

PRODUCT	OUTLET WATER TEMPERATURE	COMPLIANCE INDEX	REGULATION
Chiller	< 18°C	SEER/ηsc low temperature application	2016/2281
	≥ 18°C	SEER/ηsc medium temperature application	2016/2281
Heat pumps (reversible and only heating) Pdesign≤400kW		SCOP/ηsh	2013/813
Reversible heat pumps Pdesign>400kW	< 18°C	SEER/ηsc low temperature application	2016/2281
	≥ 18°C	SEER/ηsc medium temperature application	2016/2281
Heat pumps only heating Pdesign>400kW		-	-

- = exemption from Ecodesign

PROCESS APPLICATION

PRODUCT	OUTLET WATER TEMPERATURE	COMPLIANCE INDEX	REGULATION
Chiller	≥ +2°C , ≤ 12°C	SEPR	2016/2281
	> 12°C	-	-
	> -8°C , < +2°C	-	-

- = exemption from Ecodesign

TAU SKY HI HP RANGE

With reference to the TAU SKY Hi HP range, below is a list of concerned regulations relating to the different units in their various configurations:

- regulation 2013/813
- regulation 2013/811

The tables below give information on the conformity of the units and the seasonal energy performance ratios with regard to the reference regulation.

TAU SKY Hi HP

			6	9	12	15	19
REGULATION 2013/813							
Low Temperature Application							
Pdesign	(1)	kW	4,2	6,5	8,8	11,7	16,3
η_{sh}	(1)	%	186,7	186	185,5	196,8	190,5
SCOP	(1)		4,74	4,73	4,71	5,00	4,84
Compliance	(1)		Y	Y	Y	Y	Y
Medium Temperature Application							
Pdesign	(2)	kW	4,0	5,7	7,3	10,4	10,5
η_{sh}	(2)	%	140,1	149,5	135,8	156,0	152,6
SCOP	(2)		3,58	3,81	3,47	3,98	3,89
Compliance	(2)		Y	Y	Y	Y	Y
REGULATION 2013/811							
Ecolabel LT	(3)		A+++	A+++	A+++	A+++	A+++
Ecolabel MT	(3)		A+++	A+++	A+++	A+++	A+++

Y = unit in compliance with Ecodesign at the indicated condition.

(1) User-side heat exchanger water inlet/outlet temperature 30/35°C, Average climate profile, with reference to regulation 2013/813 and norm EN 14825.

(2) User-side heat exchanger water inlet/outlet temperature 47/55°C (SCOP MT), Average climate profile, with reference to regulation 2013/813 and norm EN 14825.

(3) Energy efficiency class with reference to regulation 2013/811 (low temperature applications).

The certified standard performances and data can be verified in <https://www.eurovent-certification.com>

Some voluntary data are not certified (i.e. Noise Level for water source units; SCOP for units with Pdesign >70 KW; SCOP MT values).

ELECTRICAL SPECIFICATIONS

TAU SKY HI HP

			6	9	12	15	19
General electrical specifications							
Max. absorbed current (FLA)	(1)	A	15,1	15,6	19,2	16,4	19,7
Rated current (Inom)	(2)	A	8,3	10	11,3	7,4	9,5
cosφ standard unit	(2)		0,95	0,95	0,95	0,95	0,95
Max. inrush current (MIC)	(3)	A	7	7	7	8,3	8,3
Power supply		V/ph/Hz	230/1/50			400/3N/50	
Power supply for auxiliary circuits		V/ph/Hz	24/1/50				
Suggested line protection (external unit)	(4)	A	16	16	25	25	25
Suggested line protection (internal unit)	(5)	A	10	10	10	10	10
Electrical specifications for fans							
Rated power of fan standard		n° x kW	1 x 0,062	1 x 0,062	1 x 0,062	2 x 0,062	2 x 0,062
Rated current of fan standard		n° x A	1 x 1,3	1 x 1,3	1 x 1,3	2 x 1,3	2 x 1,3

- (1) Data regarding the unit without accessories working in maximum power absorption conditions
- (2) Datum related to the unit without accessories working in standard conditions (A7°C; W30/35°C)
- (3) Maximum effective RMS value of the current when the last compressor starts (FLA of the entire unit - FLA of the largest compressor + LRA of the largest compressor)
- (4) These values are determined for cables with operating temperature of 40°C, EPR insulation and a line with a maximum length of 50m. The line section must be determined by a qualified technician based on the protection devices, the length of the line, the type of cable used and the type of installation.
- (5) The correct line protection part must be determined by a qualified technician based on the length of the line, the type of cable used and the type of installation.

USER-SIDE EXCHANGER FLOW RATE FIELDS

The units are sized and optimized for the following nominal conditions: outside air temperature 7°C, inlet/outlet of the user-side heat exchanger 30/35°C.

The units can work at design conditions different from nominal conditions, provided that:

1. the design condition falls within the operating limits specified below
2. the flow rate at design conditions (that is, of the specific application) must always come within the allowed flow rate ranges specified below. If the design conditions require a water flow rate that does not come within the allowed operating range, you must contact our sales department that will identify the most suitable solution for the specific application.

The water flow to the heat exchangers must be between Q_{min} and Q_{max}

TAU SKY Hi HP

	Q_{min}	Q_{max}
	m³/h	m³/h
6	0,75	2,14
9	0,94	2,72
12	1,44	2,81
15	2,23	5,3
19	2,66	6,76

OPERATING LIMITS

TAU SKY HI HP

HEATING

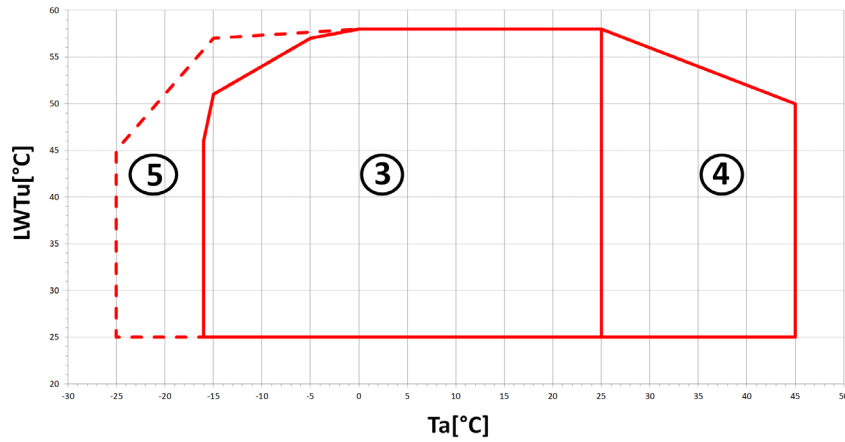

COOLING

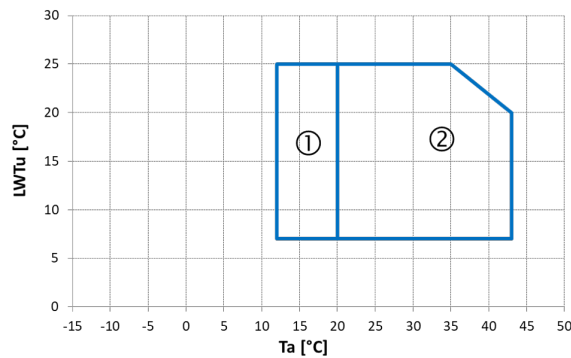

Note: The temperature difference to the user side heat exchanger must be between 3 K and 6 K.

Ta: external air temperature

LWTu: water outlet temperature from the user-side heat exchanger

1: In this area the unit can only operate in manual cooling mode

2: In this area the unit can operate in automatic mode or in manual cooling mode

3: In this zone the unit can operate in automatic heating mode

4: In this zone the unit can only operate in manual heating mode or in manual domestic hot water mode

5: in the indicated area, the control could actuate a forced capacity reduction of the compressors so as to prevent tripping of the safety devices. Intervention of compressors forced partialization could vary according to the single sizes and on specific working conditions and timing. To check the operating limits in a specific operating condition, consult the selection software.

The inlet and outlet temperatures of the user-side exchanger must be given on ordering to allow correct setting of the alarm parameters and verification of the sizing of the expansion valve.

The cooling set point can then be changed by the customer in an interval that, compared to the set point given on ordering, ranges from -1K up to the maximum temperature allowed by the above-stated operating limits.

The unit will be optimized to work at the set point temperatures given on ordering. For different set points, the cooling capacity provided and the level of efficiency of the machine could decrease and move away from these conditions.

NOISE LEVELS

TAU SKY HI HP

Octave bands [dB]	Octave bands [dB]								Total [dB(A)]	
	63 Hz	125 Hz	250 Hz	500 Hz	1000 Hz	2000 Hz	4000 Hz	8000 Hz	Lw_tot	Lp_tot
	Lw	Lw	Lw	Lw	Lw	Lw	Lw	Lw		
6	57	56	55	51	45	41	34	31	52	24
9	58	57	56	53	45	41	36	33	53	25
12	56	56	55	51	45	41	36	32	52	24
15	59	59	59	57	51	48	44	40	58	30
19	61	60	60	59	58	54	51	46	61	33

The acoustic data are related to standard conditions (source on a reflective surface in free field) in referable and reproducible operating conditions. The environment and the installation conditions, as well as the operating modes, can alter the sound emissions. All data with the exception of Lw_tot are provided for illustrative purposes only and can not be used for forecasting purposes or for the verification of binding limits.

Reference conditions: outside air temperature 7°C DB, 6°C WB; condenser inlet/outlet water temperature 30/35°C.

Lw: Values taken by measurements made in accordance with standard ISO 3744 and the Eurovent certification programme where applicable. Lw_tot is the only binding value.

Lp: Values calculated starting from noise power levels referred to a distance of 10 m from the unit; source installed on a reflective surface and in ideal free field conditions with directivity factor Q=2. No Lp value is binding.

Noise data refer to the standard conditions illustrated above, in reference and reproducible operating conditions. All data, excluding Lw_tot, are provided for the sake of exemplification and must not therefore be used for forecasting purposes or for the verification of mandatory limits. With special reference to noise emissions, the Manufacturer takes liability for their conformity, limited to the declared Lw_tot value. Any and all other Manufacturer's liability for the impact of such emissions in relation to the location of the machine and other conditions related to machine installation is excluded. Any assessment concerning these conditions falls within the area of competence of the plant designer and/or the fitter.

The certified standard performances and data can be verified in <https://www.eurovent-certification.com>

Some voluntary data are not certified (i.e. Noise Level for water source units; SCOP for units with Pdesign >70 KW; SCOP MT values).

INSTALLATION ADVICE

The units described in this document are, by nature, strongly affected by the characteristics of the system, the working conditions and the installation site.

Remember that the unit must be installed by a qualified and skilled technician, and in compliance with the national legislation in force in the destination country.

The installation must be done in such a way that it will be possible to carry out all routine and non-routine maintenance operations.

Before starting any work, you must carefully read the "Installation, operation and maintenance manual" of the machine and do the necessary safety checks to prevent any malfunctioning or hazards.

We give some advice below that will allow you to increase the efficiency and reliability of the unit and therefore of the system into which it is inserted.

Water characteristics

To preserve the life of the exchangers, the water is required to comply with some quality parameters and it is therefore necessary to make sure its values fall within the ranges indicated in the following table:

Total hardness	2,0 ÷ 6,0 °f
Langelier index	- 0,4 ÷ 0,4
pH	7,5 ÷ 8,5
Electrical conductivity	10÷500 µS/cm
Organic elements	-
Hydrogen carbonate (HCO₃⁻)	70 ÷ 300 ppm
Sulphates (SO₄²⁻)	< 50 ppm
Hydrogen carbonate / Sulphates (HCO₃⁻/SO₄²⁻)	> 1
Chlorides (Cl⁻)	< 50 ppm
Nitrates (NO₃⁻)	< 50 ppm
Hydrogen sulphide (H₂S)	< 0,05 ppm
Ammonia (NH₃)	< 0,05 ppm
Sulphites (SO₃), free chlorine (Cl₂)	< 1 ppm
Carbon dioxide (CO₂)	< 5 ppm
Metal cations	< 0,2 ppm
Manganese ions (Mn⁺⁺)	< 0,2 ppm
Iron ions (Fe²⁺ , Fe³⁺)	< 0,2 ppm
Iron + Manganese	< 0,4 ppm
Phosphates (PO₄³⁻)	< 2 ppm
Oxygen	< 0,1 ppm

Installation of water filters on all the hydraulic circuits is obligatory.

The supply of the most suitable filters for the unit can be requested as accessory. In this case, the filters are supplied loose and must be installed by the customer following the instructions given in the installation, operation and maintenance manual.

Glycol mixtures

With temperatures below 5°C, it is mandatory to work with water and anti-freeze mixtures, and also change the safety devices (anti-freeze, etc.), which must be carried out by qualified authorised personnel or by the manufacturer.

Liquid outlet temperature or minimum ambient temperature	°C	0	-5	-10	-15	-20	-25	-30	-35	-40
Freezing point	°C	-5	-10	-15	-20	-25	-30	-35	-40	-45
Ethylene glycol	%	6	22	30	36	41	46	50	53	56
Propylene glycol	%	15	25	33	39	44	48	51	54	57

The quantity of antifreeze should be considered as % on weight

Minimum water content in the system

For correct operation of the unit, it is necessary to ensure a buffering on the system such as to comply with the minimum operating time considering the greater between the minimum OFF time and the minimum ON time. In short, these contribute to limiting the number of times the compressors are switched on per hour and to preventing undesired deviations from the set point of the delivered water temperature.

The following experimental formula allows the minimum water volume of the system to be calculated:

$$V_{min} = \frac{P_{tot} \cdot 1000}{N} \cdot \frac{180}{\Delta T \rho C_p} + P_{tot} \cdot 0.25$$

where

V_{min} is the minimum water content of the system [l]

P_{tot} is the total cooling capacity of the machine [kW]

N: number of capacity reduction steps

ΔT : differential allowed on the water temperature. Unless otherwise specified, this value is considered to be 2.5K

ρ : density of the heat-carrying fluid. Unless otherwise specified, the density of water is considered

c_p : specific heat of the heat-carrying fluid. Unless otherwise specified, the specific heat of water is considered

Considering the use of water and grouping together some terms, the formula can be re-written as follows:

$$V_{min} = \frac{P_{tot}}{N} \cdot 17,2 + P_{tot} \cdot 0,25$$

N is equal to the number of compressors installed in the unit.

The value of N is 3 in units featuring an inverter-controlled compressor.

Larger amounts of water are in any case always preferable, because they allow a smaller number of starts and switch-offs of the compressors, less wear of them and an increase in the efficiency of the system as a consequence of a reduction in the number of transients.

It should also be pointed out that, for air-water units working in heat pump mode, the minimum amount of water must consider the need of the unit to carry out defrosting. Having an adequate buffering volume will allow prevention of too high drifts of the delivered water temperature at the end of the defrost cycle.

Installation site

To determine the best installation site for the unit and its orientation, you should pay attention to the following points:

- compliance with the clearance spaces indicated in the official dimensional drawing of the unit must be guaranteed so as to ensure accessibility for routine and non-routine maintenance operations
- compliance with the respect spaces indicated in the installation, use and maintenance manual must be guaranteed, in relation to units with highly flammable A3 refrigerant
- you should consider the origin of the hydraulic pipes and their diameters because these affect the radiuses of curvature and therefore the spaces needed for installing them
- you should consider the position of the cable inlet on the electrical control panel of the unit as regards the origin of the power supply
- if the installation includes several units side by side, you should consider the position and dimensions of the manifolds of the user-side exchangers and of any recovery exchangers
- if the installation includes several units side by side, you should consider that the minimum distance between units is 0,5 metres
- you should avoid all obstructions that can limit air circulation to the source-side exchanger or that can cause recirculation between air supply and intake
- you should consider the orientation of the unit to limit, as far as possible, exposure of the source-side exchanger to solar radiation
- if the installation area is particularly windy, the orientation and positioning of the unit must be such as to avoid air recirculation on the coils. If necessary, we advise making windbreak barriers in order to prevent malfunctioning.

Once the best position for the unit has been identified, you must check that the support slab has the following characteristics:

- its dimensions must be proportionate to those of the unit: if possible, longer and wider than the unit by at least 30 cm and 15/20cm higher than the surrounding surface
- it must be able to bear at least 4 times the operating weight of the unit
- it must allow level installation of the unit: although the unit is installed on a horizontal base, make slopes in the support surface to convey rain water or defrost water to drains, wells or in any case to places where it cannot generate an accident hazard due to ice formation. All heat pump version units are equipped with discharge manifolds for the condensed water; these can be manifolded to facilitate condensate discharge.

The units are designed and built to reduce to a minimum the level of vibration transmitted to the ground, but it is in any case advisable to use rubber or spring anti-vibration mounts, which are available as accessory and should be requested when ordering.

The anti-vibration mounts must be fixed on before positioning the unit on the ground.

In the event of installation on roofs or intermediate floors, the pipes must be isolated from the walls and ceilings.

It is advisable to avoid installation in cramped places, to prevent reverberations, reflections, resonances and acoustic interactions with elements outside the unit.

It is essential that any work done to soundproof the unit does not affect its correct installation or correct operation and, in particular, does not reduce the air flow rate to the source-side exchanger.

Swegon Operations s.r.l.

Via Valletta, 5 - 30010

Cantarana di Cona, (VE) Italy - T. +39 0426 921111 - F. +39 0426 302222

www.blueboxcooling.com - info@bluebox.it



Swegon Operations s.r.l. a socio unico - P.IVA 02481290282

Company directed and coordinated by Investment Latour (Sweden)