

# TITAN Zero

230÷400 kW



## General

Chiller and reversible heat pumps with full inverter reciprocating compressors and plate heat exchangers. Extended range, versatile applications.

## Configurations

Hi: chiller with inverter compressor

Hi HP: Reversible heat pump version, with inverter compressor

/SLN: super low noise version

/DS: execution featuring a desuperheater

/DC: execution with recovery condenser

## Strengths

- ▶ Refrigerant R290 - GWP≈0.
- ▶ Reduced refrigerant charge
- ▶ Eurovent Certification
- ▶ High efficiency and compact dimensions
- ▶ BlueThink advanced control with integrated web server.
- ▶ Chiller version:
  - ▶ Water temperature from -15°C up to 20°C. Operation in a wide range of environmental conditions
- ▶ Reversible heat pump version:
  - ▶ High outlet water temperature: up to +63°C
  - ▶ Down to -20°C ambient temperature with outlet water up to +50°C

**BlueBox**   
by Swegon



---

## **TITAN Zero**

<b>Description of accessories</b>	<b>12</b>
Refrigerant circuit accessories	12
Fan accessories	14
Hydraulic circuit accessories	15
Flowzer options	18
Electrical accessories	35
Network accessories	41
Other accessories	45
<b>Technical specifications</b>	<b>50</b>
<b>Ecodesign</b>	<b>54</b>
<b>Electrical specifications</b>	<b>59</b>
<b>Hydraulic modules</b>	<b>61</b>
<b>Pump data</b>	<b>62</b>
<b>User-side exchanger flow rate fields</b>	<b>63</b>
<b>Operating limits</b>	<b>64</b>
TITAN Zero Hi - TITAN Zero Hi SLN	64
TITAN Zero Hi HP - TITAN Zero Hi HP SLN	65
<b>Configurations that are not possible</b>	<b>70</b>
<b>Installation advice</b>	<b>71</b>
Water characteristics	71
Glycol mixtures	71
Minimum water content in the system	72
Installation site	73
Definitions	74
Applicable standards and regulations	75
Installation types	75
Class III hydronic unit installations in open air environments	76
Class IV installations (indoor units)	78
Hydraulic Connections	79
Guidelines for the risk assessment	80
Installation risk assessment	82
Suggestions for conducting and drawing up the risk assessment	86
Installations that require the use of treated coils	90
Aeraulic head losses and options available for the ventilating section	91



---

# TITAN Zero

TITAN Zero is a large range of high efficiency chillers and reversible heat pumps featuring with full inverter reciprocating compressors and an air source, suitable for both comfort and process applications. Units mount variable speed inverter compressors in order to maximize the seasonal efficiency and achieve stable thermodynamic regulation in any load condition. All the units have two independent refrigerant circuits and fitted with a single brazed plate heat exchangers with dual circuits on refrigerant side and a common secondary fluid circuit. The whole range is characterized by compactness and low refrigerant charge.

## REFRIGERANT

Units are available with R290 refrigerant.

The use of R290 refrigerant is indicated by acronym "R0", which indicates a GWP level close to 0.

Refrigerant R290 GWP(Global Warming Potential)=0\*

ODP (Ozone Depletion Potential) 0

The refrigerant is a pure natural fluid.

R290 is classified as group 1 fluid according to PED.

It is also classified as A3 according to ASHRAE standard 34:

- non-toxic;
- Highly flammable.

The excellent GWP value may be an advantage in projects where:

- min. targets are adopted for the containment of the environmental footprint;
- it is possible to receive incentives or other benefits that are applicable in some countries or are connected to specific plant design criteria.

(\*) GWP (AR5), pursuant to IPCC VI, evaluated over a span of 100 years.

## STRUCTURE

The structure of the unit is made of galvanized sheet-iron coated with polyester powder in RAL 5017/7035 at 180°C, which makes it highly resistant to weather conditions.

The structure is a load-bearing frame, with removable panelling lined with sound absorbing expanded polyurethane matting.

## COMPRESSORS

The compressors are semi-hermetic reciprocating in a double circuit coupled with an inverter which modulates the working frequency according to the load. Compressor are optimized for use with propane. All compressors are equipped with crankcase heater, suction and delivery valves as standard.

The compressors are enclosed in a dedicated technical compartment which can be accessed by removing the panels.

The models with two compressors (x.2) has a dedicated modulating inverter for each circuit.

The speed of the modulating compressor is varied, depending on the total heat load, roughly between 30 and 105 rps. 30Hz and 65Hz.

The modulating compressors are driven by inverters. This also has the following functions:

- management of acceleration and deceleration ramps
- management of the operating envelope of the modulating compressor
- management of the alarms and safety devices of the modulating compressor

The use of a modulating compressor allows the total inrush current to be reduced because it is always started with an acceleration ramp.

---

## **FANS**

The fans are axial fans, directly coupled to a 6-pole electric motor, with integrated thermal overload protection (Klixon®) and IP 54 protection rating.

The fan includes the shroud, designed to optimize its efficiency and reduce noise emission to a minimum, and the safety guard.

The control manages the speed of the fans through a phase cutting speed adjuster, in order to optimize the operating conditions and efficiency of the unit.

The fan speed regulator is supplied standardly.

This control also has the effect of reducing the noise level of the unit: in fact, the typical conditions under which the control will be modulating the speed of the fans are those of the night, spring and autumn.

For units equipped with EC fans (option), the same function is carried out using the electronically commutated motor of the fans.

## **SOURCE-SIDE HEAT EXCHANGER**

### **(for chiller unit)**

The exchangers are made with microchannel aluminium coils. Finned pack coils with copper tubes and aluminium fins can be requested as accessory.

Thanks to continuous research in the alloys field, and sophisticated production methods, microchannel coils are made using specific aluminium alloys for the tubes and for the fins. This allows the effects of galvanic corrosion to be drastically reduced to always ensure protection of the tubes that confine the refrigerant. Tubes and fins are also subjected to SILFLUX coating processes (or equivalent) or have zinc added to further increase their corrosion resistance.

The use of microchannel coils, as opposed to conventional copper/aluminium coils, reduces the total weight of the unit and reduces the refrigerant charge.

Options are available for installation in environments with a particularly aggressive atmosphere or in coastal or highly industrialized areas. See section: "Description of accessories".

### **(for HP units)**

Coils are finned pack type and they consist of copper tubes and aluminium fins with corrugated profile and hydrophilic surface treatment.

The coils have an increased fin pitch to reduce frost formation and to facilitate the outflow of condensed water during defrosting.

Options are available for installation in environments with a particularly aggressive atmosphere or in coastal or highly industrialized areas. See section: "Description of accessories".

At the base of the coils there is a collection tray as standard which facilitates the drain of condensate during the defrost (accessory VASC).

The unit is fitted as standard with a heating cable glued to the bottom of the condensate tray to prevent formation of ice (accessory RAV).

The RAM accessory includes installation of a heater at the bottom of the coil. Recommended accessory for installations in regions with temperatures below -5°C or in the case of installations particularly exposed to cold winds.

Heaters are managed with a thermostat, activated depending on outside air temperature.

## **USER-SIDE HEAT EXCHANGER**

The exchanger is a braze-welded stainless steel plate heat exchanger, insulated with a shroud of closed-cell insulating material.

The exchanger is also equipped with thermostat-controlled anti-freeze heater to protect it from ice formation when the unit is not running.

The antifreeze heater is also activated in the following cases unit refrigerant detector fault and unit refrigerant detector activation

---

## REFRIGERANT CIRCUIT

Each refrigerant circuit of the basic unit comprises:

### (for chiller unit)

- compressor
- pressure transducers for reading high and low pressure values
- high pressure switch
- delivery shut-off valve
- non-return valve
- safety valve
- condenser
- liquid receiver(option)
- liquid line valve
- charging valves
- dehydrating filter
- solenoid valve liquid line(option)
- liquid sight glass
- electronically-controlled thermostatic expansion valve
- Plate heat exchanger
- suction shut-off valve

### (for HP units)

- compressor
- pressure transducers for reading high and low pressure values
- high pressure switch
- delivery shut-off valve
- safety valves
- 4-way reversing valve
- condenser
- non-return valve
- safety valve
- charging valves
- dehydrating filter
- solenoid valve on the liquid line
- liquid sight glass
- electronically-controlled thermostatic expansion valve
- evaporator
- suction separator
- suction shut-off valve
- liquid receiver

The copper pipes are sized with increased thicknesses in order to ensure greater reliability and durability over time. The pipes of the circuit and the exchanger are insulated with extruded closed-cell expanded elastomer. The refrigeration circuit is enclosed in a compartment that contains an ATEX certified leak sensor and an ATEX certified extraction fan. The hydronic module, if present, is also enclosed in the compartment that contains the ATEX certified leak sensor and the ATEX certified extraction fan.

## ELECTRICAL CONTROL PANEL

The electrical control panel is made in a painted galvanized sheet-iron box with forced ventilation and IP54 protection rating.

The electrical panel is made following the EN60204-1 standard.

The electrical panel is separated from the compressor compartment.

The electrical control panel of the basic unit comprises:

- general disconnect switch three-phase line
- fuses to protect the compressors, fans and auxiliary circuits
- fan contactors
- phase-cutting fan speed adjuster
- thermal magnetic circuit breakers for pumps (if present)
- phase monitor
- potential-free general alarm contacts
- single potential free operating contacts for compressors, fans and pumps (when present)
- digital input for general ON/OFF
- summer/winter selection by digital input
- external air temperature probe
- microprocessor controller with display accessible from the outside

All the electrical cables inside the panel are numbered and the terminal board dedicated to the customer's connections is coloured orange so that it can be quickly identified in the panel.

The unit power supply is 400V/3~+N/ 50Hz for all models.

---

## **CONTROL BLUETHINK**

The unit is supplied as standard with an advanced controller.

The control allows the following functions:

- water temperature adjustment, with outgoing water control
- freeze protection
- compressor timings
- automatic rotation of compressor starting sequence
- recording of the log of all machine inputs, outputs and states
- automatic rotation of compressor starting sequence
- recording of the alarm log
- RS485 serial port with Modbus protocol
- Ethernet serial port with Modbus protocol and integrated web server preloaded web page
- digital input for general ON/OFF
- digital input for Summer/Winter selection

For further details on available functions and on displayed information, refer to the specific documentation of the controller.

By default, the serial connections present as standard are enabled only for reading from BMS. Enabling of writing from BMS is to be requested when ordering.

### **Main functions of the webserver**

As standard, the Bluethink controller integrates a webserver with a preloaded web page that is accessed via password. The web page allows the following functions to be carried out (some of these are available only for users with advanced level rights):

- display of the main functions of the unit such as unit serial n°, size, refrigerant
- display of the general status of the machine: water inlet and outlet temperatures, external air temperature, mode (chiller or heat pump), evaporating and condensing pressures, suction and discharge temperatures
- display of the status of compressors, pumps, expansion valves
- display in real time of the graphs of the main quantities
- display of the graphs of logged quantities
- display of alarm log
- management of users on several levels
- remote ON/OFF
- remote set point change
- remote time band change
- remote summer winter mode selection

### **Human-Machine Interface**

The control has a graphic display that allows the following information to be displayed:

- water inlet and outlet temperature
- set temperature and differential set points
- description of alarms
- hour meter of operation and number of start-ups of the unit, the compressors and the pumps (if present)
- high and low pressure values, and relevant condensing and evaporating temperatures
- external air temperature
- superheating at compressor suction.

---

## **Management of defrost cycles**

For defrost management, the control of the unit uses a sliding intervention threshold, depending on the pressures inside the unit and the external air temperature. By putting together all this information, the control can identify the presence of ice on the coil and activates the defrosting sequence only when necessary, so as to maximize the energy efficiency of the unit.

Sliding management of the defrost threshold ensures that, as the absolute humidity of outdoor air decreases, the frequency of the defrost cycles gradually decreases because they are carried out only when the ice formed on the coil actually penalizes performance.

The defrost cycle is fully automatic: during the initial stage, a defrost is carried out by cycle reversal with the fans stopped. As soon as the frost on the coil has molten to a suitable level, the unit resumes operation in heat pump mode. In the two-compressor units, there is aeraulic separation between the two circuits, and this allows the management of independent defrosts with greater stability in the production of hot water.

---

## VERSIONS

### **/SLN: super low noise unit**

The standard unit requires all compressors to be enclosed within a fully acoustically insulated compartment with sound-absorbing material with interposed sound-proofing material.

The SLN version units use fans with speed regulators with reduced air flow in chiller operation. The speed reduction of the fans is such that, under nominal operating conditions, the air flow rate and noise level are lower than those of the basic version of the unit.

In any case, the use of the speed adjuster to reduce the air flow rate allows rotation of the fans at maximum speed when external air temperature conditions are particularly critical and therefore guarantees the same operating limits as the high efficiency version.

In heating mode, the fans always run at 100% speed.

### **/HAT: unit for high external air temperatures**

The HAT option is designed to expand the work range of the unit.

The unit fitted with this accessory adopts an electrical control panel made using specific components to withstand high temperatures, special cables and oversize protection parts.

For certain sizes this option requires a larger inverter.

The accessory enables the unit to work with external air temperatures of over 45°C as indicated in the section on operating limits.

With this accessory, operation is guaranteed with external air temperature up to 52°C.

### **/DC: unit with total recovery condenser**

In addition to the set-up of a chiller only unit, /DC units comprise:

- a heat recovery condenser for recovering 100% of the condensation heat;
- temperature probe at the inlet of the heat recovery heat exchanger;
- liquid receiver
- potential free contact in the electrical control panel for activation of recovery.

When required by the system, through the closing of a contact, the control automatically manages activation of recovery. Recovery management is carried out through a control on the temperature of the return water. The control also automatically manages safety deactivation of recovery if the condensing pressure becomes too high, and changes to using the condensing coils.

This option is not available for /HP units

### /DS: unit with desuperheater

/DS units comprise (for each refrigerant circuit) an exchanger for condensation heat recovery of up to 20% (depending on size, version and operating conditions), placed in series with the condensing coil. The exchanger is a braze-welded plate heat exchanger. For multi-circuit units, the exchangers are to be manifolded outside the unit (by the customer). The desuperheater can be used during operation in cooling mode. However, it can also be used in heating mode on condition that the following measures are taken:

- a valve (either 2- or 3-way) must be installed on the desuperheater water circuit;
- the valve must be monitored using a temperature control system;
- the valve must be operated to regulate the temperature of the input water into the desuperheater = IWTds.

First, enter the unit heating setpoint, which corresponds to the temperature of water delivered to the heating unit=LWTu\_Heating. Then set the condition below:

- IWTds > LWTu\_Heating + 10 [K]

The valve, the control systems and their installation, setup operations, etc. are the responsibility of the client. If heat recovery is not required during operation in heat pump mode, or where the above requirements are not met, the water circuit of the desuperheater must be shut off. Desuperheater operation in heat pump mode reduces the heating capacity transferred from the unit to the user's hydronic circuit. When a desuperheater is fitted, irrespective of it running in either cooling or heating mode, the max. temperature of water delivered to the heating unit (LWTu\_Heating) is reduced, as described in the section "Operating limits".

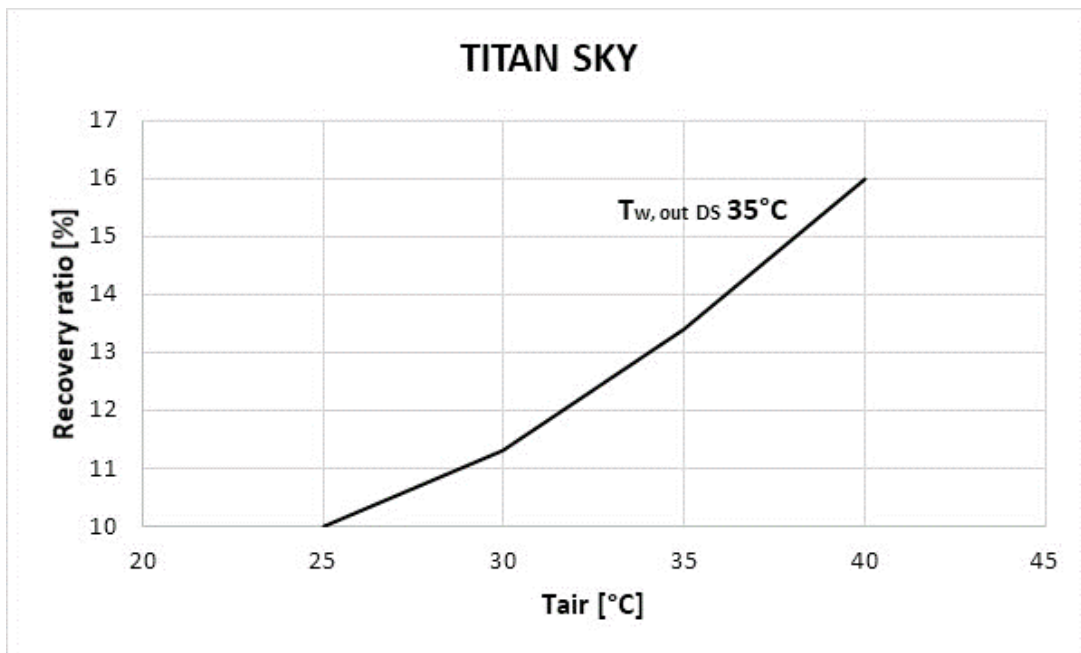

An illustrative graph is shown below in which, as the ambient temperature changes, (Tair) and as the temperature of the water leaving the heat recovery heat exchanger changes, (Tw,out DS), the percentage of recovered heat is shown as an indication (Recovery ratio).

Condensation heat recovery is a function of size, version and operating conditions.

The percentage of recovered heat is calculated as the ratio between recovered heat flow to the desuperheater and the heat flow to the condenser under nominal conditions, therefore evaporator inlet-outlet water temperature 12-7°C.

In the following graph, a constant temperature delta of 5°C between water inlet and outlet at the heat recovery heat exchanger has been considered.

## HYDRAULIC MODULES

All units can be fitted with hydraulic module in various configurations:

- /1P: hydraulic module with one pump
- /2P: hydraulic module with two pumps
- /1PS: hydraulic module with one pump and buffer tank
- /2PS: hydraulic module with two pumps and buffer tank

The following are also available:

- modules /1Pr, /2Pr, /1PrS e /2PrS that have pumps with reduced available discharge head
- modules /1PG, /2PG, /1PGS and /2PGS that have pumps suitable for operating with glycol up to 40%

Hydraulic modules with one pump have:

- one pump
- an expansion vessel

Hydraulic modules with two pumps have:

- two pumps
- a check valve on the delivery side of each pump
- an expansion vessel

In the version with 2 pumps, these are always with one on standby while the other is working. Switching over between the pumps is automatic and is done by time (to balance the hours of operation of each one) or in the event of failure.

Hydraulic modules with tank also have:

- a gate valve at the inlet of the pump or the suction manifold
- a tank with drain valve and air valve

Refer to the table of configurations that are not possible to check for availability of specific set-ups.

All the hydraulic circuit components are fully insulated, except for:

- drain valves
- venting valves
- tank plugs
- expansion vessel
- probe pockets

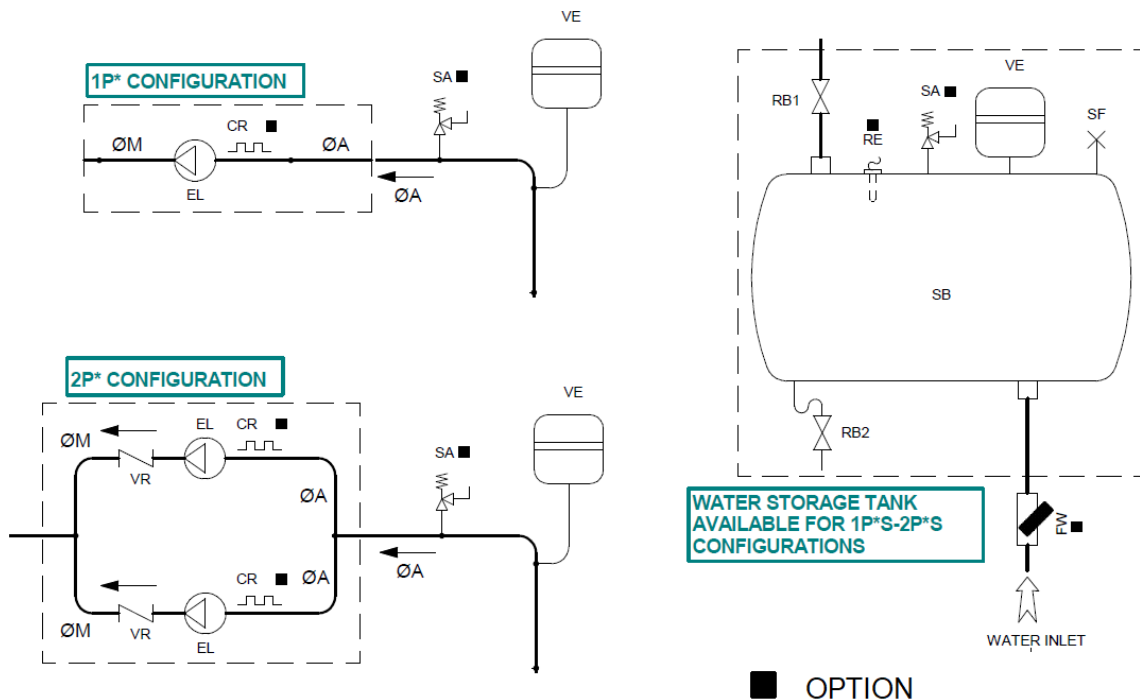

---

## **CONTROLS AND SAFETY DEVICES**

All the units are fitted with the following control and safety components:

- user-side water temperature probe
- antifreeze probe on the user side heat exchanger
- high pressure switch with manual reset
- low pressure safety device with automatic reset, for a limited number of occurrences, managed by the controller
- compressor overtemperature protection
- fan overtemperature protection
- water differential pressure switch
- ATEX certified leakage sensor
- ATEX certified extraction fan

In the event that the leak detector identifies a gas leak, the following safety procedures are implemented:

- immediate shutdown of the unit
- interruption of the three-phase main power supply
- activation of the extraction fan
- activation of the ventilation fans of the electrical panel

## **TESTING**

All the units are factory-tested and supplied complete with oil and refrigerant.

## **PACKAGING**

The unit is wrapped in a protective transparent polyethylene stretch film.

## **CERTIFICATIONS AND REFERENCE STANDARDS**

The manufacturer has implemented and keeps the Management Systems listed below and it is certified against them:

- Quality Management System according to standard UNI EN ISO 9000;
- Environmental Management System according to standard UNI EN ISO 14000;
- Health and Safety Management System according to standard BS OHSAS 18000 (as converted into UNI EN ISO 45000).

These management systems ensure that the company puts in place any and all actions and initiatives to define and monitor the standards defined by its Management, which are stated in its Quality, Environmental and Safety policies.

To meet the safety requirements, the unit was designed and manufactured in compliance with the directives and product regulations below:

- PED Directive: safety criteria to be followed when designing pressure equipment;
- Machinery Directive: safety criteria to be followed when designing machinery;
- Low Voltage Directive: safety criteria to be followed when designing electrical machine parts;
- Electromagnetic Compatibility Directive: electromagnetic compatibility criteria to be followed when designing electrical machine parts;
- WEEE Directive: criteria for product management at the end of its life cycle as waste with a view to environmental protection.

The units are manufactured, tested and checked with reference to the European standards specified in the Declaration of CE Conformity, in accordance with the requirements and procedures of our Quality System.

The transport, installation, use and storage of units with flammable refrigerants (A3 according to ASHRAE 34 standard) must meet European standards and regulations and local regulations where applicable.

For further details, please refer to the "Instruction manual for operation and maintenance".

### **Responsibilities and obligations exclusive to the installer:**

- to carry out a specific risk assessment according to the European regulations/standards above and/or the local laws in order to define the necessary measures for conformity;
- to comply with the requirements and to take the measures resulting from the outcomes of the risk assessment, pursuant to the relevant regulations and standards.

---

## DESCRIPTION OF ACCESSORIES

Some accessories may be incompatible with each other even if not expressly indicated.

### Refrigerant circuit accessories

---

#### **RG Fan speed adjuster**

This option is standard.

The control manages the speed of the fans through a phase cutting speed adjuster, in order to optimize the operating conditions and efficiency of the unit.

This control also has the effect of reducing the noise level of the unit: in fact, the typical conditions under which the control will be modulating the speed of the fans are those of the night, spring and autumn.

For units equipped with EC fans, the same function is carried out using the electronically commutated motor of the fans and is supplied as standard.

#### **MAFR Pressure gauges**

The operating pressures of each circuit of the unit can be displayed on the control by accessing the relevant screens. Also, the machine can be fitted with pressure gauges (two for each circuit) installed in a clearly visible position. These allow reading in real time of the working pressures of the refrigerant gas on the low pressure side and on the high pressure side of each refrigerant circuit.

#### **\*\*non tradotto\*\* Liquid line valve**

This option is standard.

The valves situated on the delivery side and on the suction side of the compressors allow the compressor to be isolated from the rest of the refrigerant circuit, so making the maintenance operations quicker and less invasive

#### **DVS Double safety valve**

With this accessory, instead of each individual safety valve per circuit, there is a "candelabrum" with two safety valves and a diverter valve for choosing the valve in operation. This allows the safety valves to be replaced without having to drain the machine.

#### **VTE Electronic expansion valve**

This option is standard.

The use of this component is particularly advisable on units operating in very variable heat load or operating mode conditions, as in the case of joint management of air conditioning and high temperature water production. The use of an electronic thermostatic valve allows you to:

- maximize heat exchange at the evaporator
- minimize response times to changes in load and operating conditions
- optimize control of overheating
- ensure maximum energy efficiency

#### **VS Liquid line solenoid valve**

This option is standard in HP units.

This accessory prevents refrigerant migration that could damage the compressor on starting.

---

**RPR Refrigerant leak detector**

This option is standard.

The device immediately identifies any refrigerant leaks. When 10% of the LFL is exceeded the detector activates the ventilation of the technical compartment, the ventilation of the electrical panel (if not activated already), switches on the red lamp on the door of the electrical panel, closes a clean contact, with a specific remote control, cuts off the power supply to the electrical panel, except for the power supply connections to the detector and of the extractor fan.

**RIC Liquid receiver**

The adoption of this accessory always guarantees correct feeding of the expansion valve even when the unit is subjected to wide external air temperature ranges.

This accessory is standard on DC and HP units.

**BK Brine Kit**

This accessory is compulsory if a water temperature set point lower than +5°C is used (if the unit is provided with double set point or variable set point, the lower set point is considered).

The accessory consists of increased insulation and suitable sizing and calibration of some components.

The inlet and outlet temperatures of the user-side exchanger must be given on ordering to allow correct setting of the alarm parameters and verification of the sizing of the expansion valve.

The cooling set point can then be changed by the customer in an interval that, compared to the set point given on ordering, ranges from -1K up to the maximum temperature allowed by the above-stated operating limits.

The unit will be optimized to work at the set point temperature given on ordering. For different set points, the cooling capacity provided and the level of efficiency of the machine could decrease and move away from these conditions.

---

## Fan accessories

---

### **VEC EC fans**

With this accessory, EC fans, with electronically commutated brushless motor, are used for the ventilating section. These guarantee very high efficiency levels for all working conditions and allow a 15% saving on the power absorbed by each fan working at full capacity.

Also, through a 0-10V analogue signal sent to each fan, the microprocessor carries out condensation/evaporation control by continuous adjustment of the air flow rate as the external air temperature changes, with a further reduction in electrical absorption and noise emission.

For further details, see the dedicated chapter: "Aeraulic head losses and options available for the fan section".

### **VEM Oversize EC fans**

The increased EC fans allow to obtain the same benefits as EC fans and in addition allow to have a residual useful head of about 100Pa.

For further details, see the dedicated chapter: "Aeraulic head losses and options available for the fan section".

---

## Hydraulic circuit accessories

---

### **IVPO Soundproofed pump compartment**

This option is standard.

With this accessory, the motor and the impeller of the pumps are enclosed in a compartment that is fully soundproofed with sound absorbing material and soundproofing material.

### **RA Antifreeze heater**

These are electric heaters inserted on the user-side heat exchanger, on the pumps and in the tank (depending on the configuration of the machine) to prevent damage to the hydraulic components due to ice formation during periods when the machine is stopped. The antifreeze heater is present as standard on the user-side heat exchanger alone.

Based on normal operating conditions and the percentage of glycol in the system, an appropriate "antifreeze alarm" temperature is set in the control. When a temperature that is 1K higher than the antifreeze alarm threshold is detected at the outlet from the exchanger, the pump (if present) and the antifreeze heaters are switched on. If the temperature of the outgoing water reaches the antifreeze alarm threshold, the compressors are stopped, keeping the heaters and the pumps active, and the general alarm contact of the machine is activated.

The antifreeze heaters are also activated in the following cases unit refrigerant detector fault and unit refrigerant detector activation

### **RAR Electric antifreeze heater on recovery heat exchanger (partial and total)**

Electrical heater installed on recovery heat exchanger (de-superheater or total heat recovery) to avoid ice formation and consequent damages in particular conditions or during stop of the unit.

A suitable threshold temperature is set according to the operating conditions to avoid ice formation. When a temperature below the threshold is detected at the exchanger outlet, the antifreeze resistances are switched on.

### **FLUS Flow switch (instead of the water differential pressure switch)**

As an alternative to the differential pressure switch (standard flow sensor), it is possible to request the paddle flow switch as accessory. This detects when there is no water flow to the user-side exchanger and sends a signal to the control of the unit that will stop the compressors to prevent damage to the exchangers.

Application of this accessory is compulsory for units that use non-glycol water and work with a yearly cycle where external air temperatures are zero or below.

The flow switch is supplied loose (installation by the customer) and replaces the water differential pressure switch (standard).

### **FW Water filter**

To protect the elements of the hydraulic circuit (in particular, the exchangers), there are Y filters that can stop and settle the particles that are normally present in the water flow and would otherwise settle in the more delicate parts of the hydraulic circuit and damage its heat exchange capacity.

Installation of the water filter is mandatory even when it is not supplied as an accessory.

Accessory supplied loose.

### V3 Three-way valve for domestic hot water management

This is a three-way on-off valve, complete with servo control. The unit controller can manage two separate hydraulic circuits through this valve: one for comfort and one for domestic hot water production.

The valve and the servo control are for indoor installation and they require the ambient temperature not to drop below  $-10^{\circ}\text{C}$ .

Accessory supplied loose. Installation by the customer.

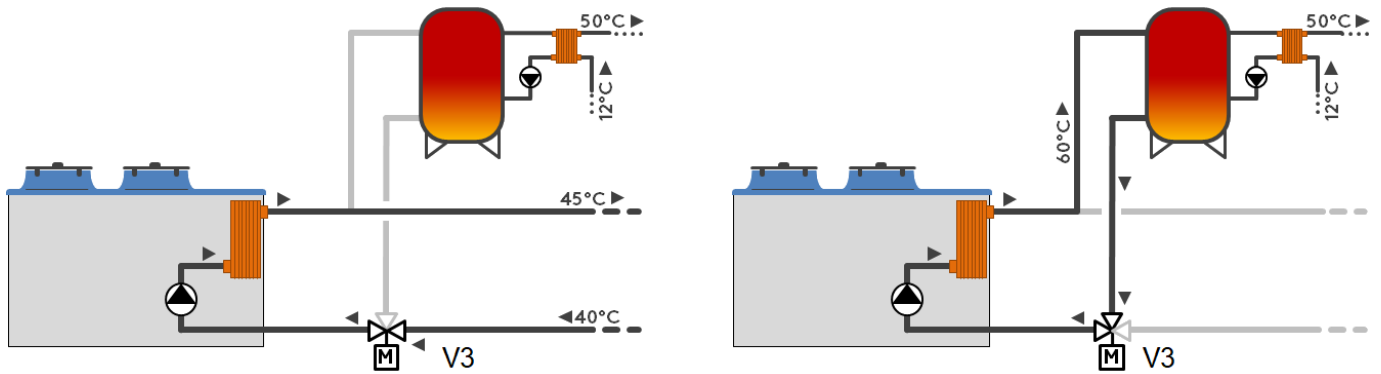

### V3MC 3-way modulating valve on hot circuit

(for HP units)

The accessory involves the supply of a 3-way modulating valve to be inserted on the hot circuit in order to check that the temperature of the water entering the exchanger is always higher than the minimum allowed.

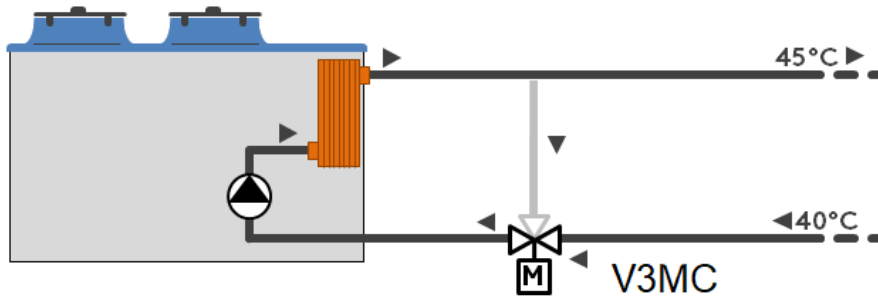

---

**SID**    **Hydraulically disconnected tank**  
(for HP units)

This accessory is mandatory on units fitted with the "Automatic management of domestic hot water" accessory and a hydraulic module with tank (1PxS or 2PxS).

The tank fitted in the unit will have an inlet and outlet, flush with the machine profile, and will be disconnected from the remaining hydraulic circuit. This will allow correct enabling of the 3-way valve for domestic hot water management, thus avoiding going through the buffer tank during domestic hot water production.

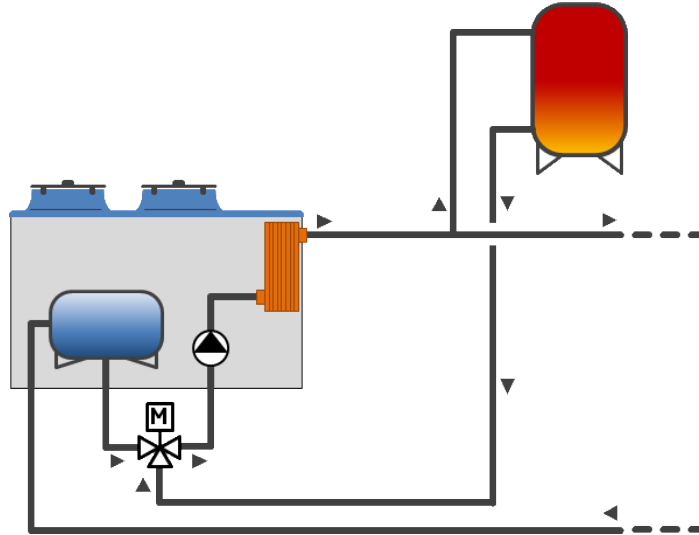

---

## Flowzer options

Our range of Flowzer options offers flexible and scalable solutions to set the speed of pumps in the system with a view to optimising and reducing energy consumption. Different types of control modes are offered based on the system and application type:

- FLOWZER VP - Inverter for manual pump adjustment
- FLOWZER VD - control of available pump discharge head for variable flow systems without monitoring the flow rate limits;
- FLOWZER VDE - flow rate control to keep the flow rate constant as the external working conditions of the system change;
- FLOWZER VDT - flow rate control with constant TD (difference between input and output temperature in the heat exchanger on the user side) in variable flow pumps, without monitoring the flow rate limits;
- FLOWZER VFPP - automatic management of variable flow rate in systems with one single primary circuit and a bypass valve;
- FLOWZER VPS - automatic management of variable flow rate, including balancing of flow rates between primary and secondary circuits;
- flowzer vps with TD-based control - automatic management of variable flow rate, including control with constant TD (difference between input and output temperature in the heat exchanger on the user side) in systems featuring both the primary and secondary circuits.

The tables below summarise the main system diagrams and show the application type and advantages/disadvantages offered by each solution. Each individual option is illustrated and explained individually in the next pages.

The hydraulic diagrams in this document are for exemplification purposes only and their main function is to help the reader understand the type of machines and devices the controller can manage. For a more technical evaluation of the system, please refer to the dedicated manual.

**FVP FLOWZER VP - Inverter for manual pump adjustment**

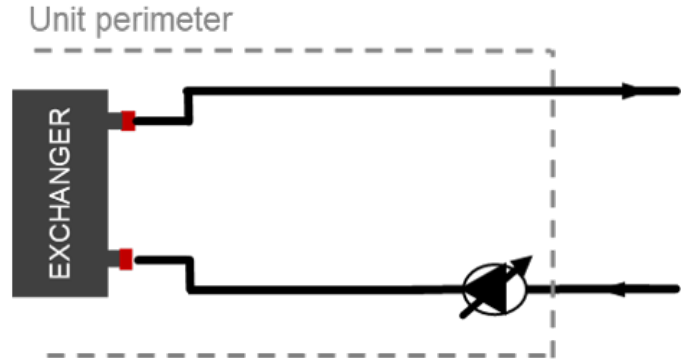

The accessory consists of inserting an inverter in the machine to manually adjust the speed of the pump (or pumps) in order to calibrate the pump flow rate on the head losses of the system. This accessory is to be combined with one of the integrated hydraulic modules that can be selected for the unit. Units equipped with integrated hydraulic module allow a certain level of available discharge head (point A) to be obtained under nominal flow rate conditions  $Q_d$ . But the actual head loss level of the system (e.g. characteristic curve  $R'$ ) normally causes the pump to find a different equilibrium point (point B), with a flow rate  $Q_r$  higher than  $Q_d$ . In this condition, in addition to having a different flow from the nominal one (therefore also a different temperature jump), there is also a greater absorption of electric power from the pump itself.

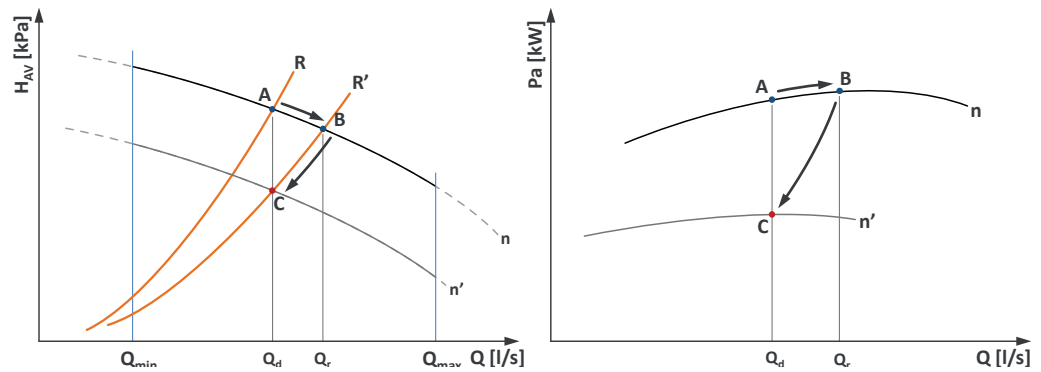

The use of the Flowzer allows the pump speed to be set manually (e.g. at speed  $n'$  instead of  $n$ ) to obtain the design water flow rate and thermal gradient (point C). Once the adjustment procedure has been carried out, the pump will always work at a fixed flow rate. The adoption of the VP Flowzer allows to considerably reduce the electrical power consumption of the pump with a consequent energy saving. By way of example, a reduction in the flow rate of 10% leads to a reduction in power consumption of around 27%. For the freecooling units the Flowzer VP is able to manage two different speeds of the pump automatically compensating the pressure drops of the water coil.



**Constant flow system**

	Application	Advantages	Disadvantages
<b>Flowzer VP</b>	<p>Ideal for constant flow systems The option is given to set two different speeds: one for heating and one for cooling mode or one for chiller and one for FC mode. This solution replaces the 2-way regulating valve.</p>	<ul style="list-style-type: none"> <li>- Increased efficiency: increased "REAL" EER of the unit installed, considering the power consumption of the pumps in real installation conditions and in real operating conditions.</li> <li>- Reduced installation times and costs: quick setup of water flow using the display.</li> </ul>	<p>This solution doesn't allow to save energy in the pump under part load conditions, due to the possibility to only set two frequency values in the inverter.</p>
<b>Flowzer VDE</b>	<p>Ideal for constant flow systems to keep the water flow to the heat exchanger constant under all conditions</p>	<ul style="list-style-type: none"> <li>- Plug&amp;Play: provides for easy and flexible implementation as it is not supplied with options to be fitted therefore allows for quick commissioning.</li> </ul>	<p>This solution is less efficient as losses in the heat exchanger are kept constant under all conditions (including in cases when they may be reduced).</p>

**FLOWZER VP**

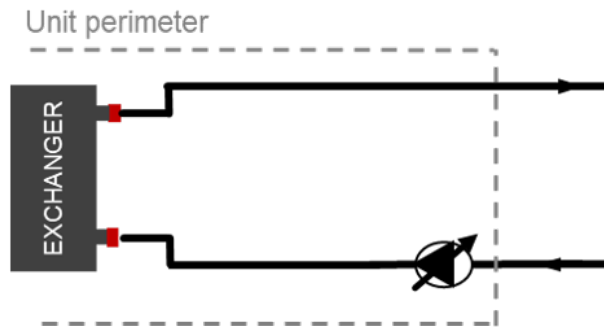

**FLOWZER VDE**

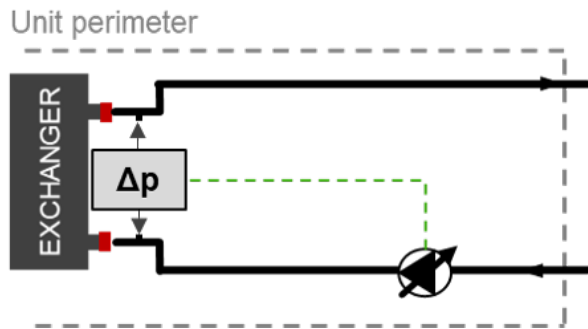

---

**FVDT FLOWZER VDT - flow rate control with constant TD (difference between input and output temperature in the heat exchanger on the user side) in variable flow pumps, without monitoring the flow rate limits;**

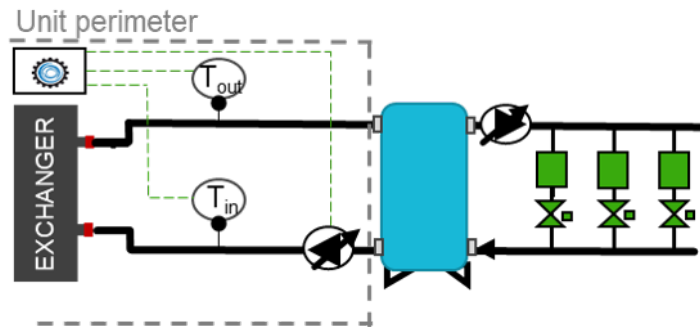

Flowzer VDT uses the temperature sensors installed at the inlet and outlet of the heat exchanger to automatically adjust the pump speed, thus keeping the T delta difference setpoint constant.

The option is not compatible with the Multilogic version. Please refer to the HYZER solutions for the compatibility between variable flow systems and multi-machine systems.

The unit must include the advanced Bluethink controller and just one heat exchanger on the user side.

With the Flowzer VDT, the customer can set, directly on the display, the available delta T value that the unit must maintain. The customer will have to check that, in minimum flow rate conditions (that is, with the maximum number of user points closed), this is always higher than or equal to the minimum flow rate allowed by the unit.

This option is specifically designed for systems in which the system users have similar operating conditions (same temperature difference).

**FVPS FLOWZER VPS - automatic management of variable flow rate, including balancing of flow rates between primary and secondary circuits;**

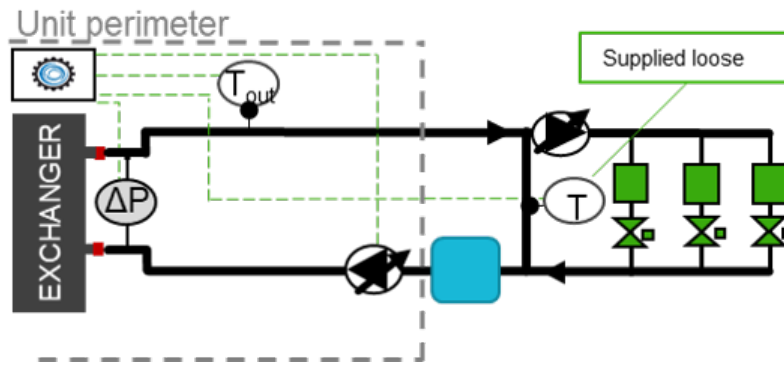

Bluethink solution for a variable flow rate system, consisting of a primary circuit plus secondary circuit. It is obligatory for the option to be combined with the Flowzer VP (inverter) and with one of the hydraulic modules that can be selected for the unit. The accessory is not compatible with Multilogic. Please contact our sales department for further details.

The unit must include the advanced BlueThink controller and just one heat exchanger on the user side. The option offers a complete default package to guarantee simple selection, purchasing and commissioning. It is obligatory for the option to be combined with the Flowzer VP (inverter) and with one of the hydraulic modules that can be selected for the unit. The accessory is not compatible with Multilogic. Please contact our sales department for further details.

For single-circuit units in case of low system load (indicatively less than 50% of the nominal capacity of the unit at the given condition), the use of the variable flow rate may result in a greater oscillation of the supply water temperature than to a fixed flow management.

The option offers a complete default package to guarantee simple selection, purchasing and commissioning. Flowzer VPS has the advantage of:

- being ideal for renovations of existing systems, especially for comfort applications
- achieving a complete variable flow system, with maximum energy saving
- implementing a flexible design, e.g. for scalable or multi-zone systems

The maximum energy saving is achieved thanks to the advanced algorithm, which prevents hunting by the inverter and balances the pump speed and the recirculation flow rate to a minimum.

With refurbishments, the system's capex is limited to the unit and its commissioning.

The dimensions of the inverter of the unit and of the pump module can be favoured by the low design discharge head of the primary circuit.

The operating principle can be summarized as follows:

- Flowzer VPS performs a smart check of the flow rate in the primary circuit and balances it with the flow rate in the secondary circuit.
- the system controller modulates the pump speed according to the condition detected by the system sensors T
- if the system terminals are switched off, the flow rate of the secondary circuit will decrease; therefore the direction of flow is detected indirectly as temperature difference by the system sensors through the separator or the bypass pipe
- The check thus contributes to reducing the speed of the primary pump until the min. flow threshold in the heat exchanger of the unit is exceeded.
- this flow rate is indirectly monitored through the losses detected by the differential pressure transducer  $\Delta p_e$

In the required minimum load condition (that is, with all system terminals switched off) the necessary minimum volume ( $V_{min}$ ) must be ensured by the relevant tank to be installed between the unit and the separator or the bypass pipe.

The temperature sensors of the system T provide a 4-20 mA signal and require 1/2" female fittings.

Further details can be found in the relevant manual.

**FVPD FLOWZER VPS with TD-based control - automatic management of the variable flow rate, including control with constant temperature difference (TD) in the heat exchanger on the user side in systems featuring both the primary and secondary circuits.**

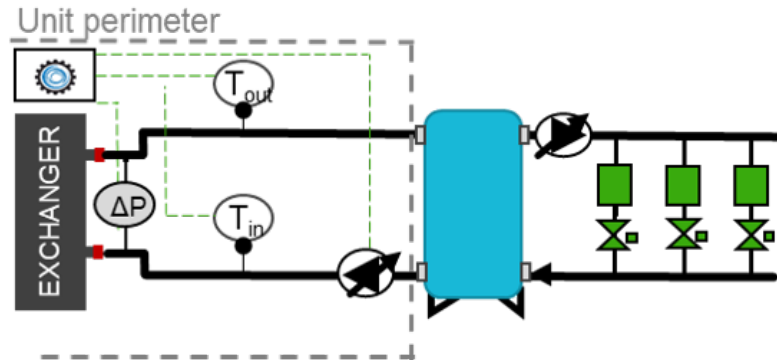

Bluethink solution for variable flow systems - ideal for systems featuring a primary and a secondary circuit physically divided by a heat exchanger or a tank with multiple connections.

flowzer vps with TD-based control includes:

- a differential pressure transducer, installed at the factory at the ends of the user-side heat exchanger of the unit ( $\Delta p_e$ )

The option must be necessarily combined with the Flowzer VP (inverter) and with one of the hydraulic modules that can be selected for the unit. The option is not compatible with the Multilogic version. Please refer to the HYZER solutions for the compatibility between variable flow systems and multi-machine systems.

For single-circuit units in case of low system load (indicatively less than 50% of the nominal capacity of the unit at the given condition), the use of the variable flow rate may result in a greater oscillation of the supply water temperature than to a fixed flow management.

The option offers a complete default package to guarantee simple selection, purchasing and commissioning.

flowzer vps with TD-based control offers the following advantages:

- a full package that is easy to install as all the regulating devices are pre-assembled and pre-wired in the unit;
- achieving a complete variable flow system, with maximum energy saving
- the ideal solution to refurbish existing systems where the T different must be kept constant in the system, especially in comfort applications;

The maximum energy saving is achieved thanks to the advanced algorithm, which prevents hunting by the inverter and balances the pump speed and the recirculation flow rate to a minimum.

The dimensions of the inverter of the unit and of the pump module can be favoured by the low design discharge head of the primary circuit.

The operating principle can be summarized as follows:

- flowzer vps with TD-based control performs smart monitoring of the flow rate in the primary circuit, keeping the T difference constant in the heat exchanger;
- the system controller modulates the pump speed according to the condition detected by the temperature sensors (T) in the system, which are installed at the inlet and outlet of the heat exchanger on the user side;
- the difference in the water temperature (T) and flow rate are inversely proportional, which is why if the T difference is reduced at the same performance level, the water flow exceeds the flow required by the system and the pump speed is reduced in order to save energy;

on the other hand, when the load increases, the T difference increases in the system and the pump speed is increased accordingly.

- The check contributes to reducing/increasing the speed of the pump in the primary circuit until the min./max. flow threshold admitted in the heat exchanger of the unit is exceeded.

- this flow rate is indirectly monitored through the losses detected by the differential pressure transducer  $\Delta p_e$

The temperature sensors of the system output a 4-20 mA signal.

Further details can be found in the relevant manual.

**Variable flow system featuring primary and secondary circuits**

	Application	Advantages	Disadvantages
<b>Flowzer VPS</b>	Ideal for all systems featuring a primary and a secondary circuit divided by a hydraulic bypass branch	<ul style="list-style-type: none"> <li>- Energy saving: the energy consumption during pumping operations can be cut down to 55% if compared with a traditional system</li> <li>- Enhanced comfort: correct balancing between primary and secondary loop</li> </ul>	Only recommended in systems featuring a primary and a secondary circuit divided by a bypass pipe; not flexible for other applications
<b>Flowzer VDT</b>	Ideal for systems featuring similar users or users with similar operating conditions. It is recommended in structured systems in which the client has third-party systems to control the min. and max. flow rate.	<ul style="list-style-type: none"> <li>- Plug&amp;Play: provides for easy and flexible implementation as it is not supplied with options to be fitted and for quick commissioning.</li> </ul>	Risk of over- or underflow for some of the users in the secondary circuit if they have different operating conditions (same temperature difference) A control is required by third-party equipment to ensure compliance with the unit flow limits.
<b>FLOWZER VPS with TD-based control</b>	Ideal for systems featuring similar users or users with similar operating conditions. Ideal for systems featuring a primary and a secondary circuits physically divided from the heat exchanger or a tank with multiple connections.	<ul style="list-style-type: none"> <li>- Plug&amp;Play: provides for easy and flexible implementation as it is not supplied with options to be fitted and for quick commissioning.</li> </ul>	Risk of over- or underflow for some of the users in the secondary circuit if their temperature difference is not the same due to the existing operating conditions

**FLOWZER VPS**

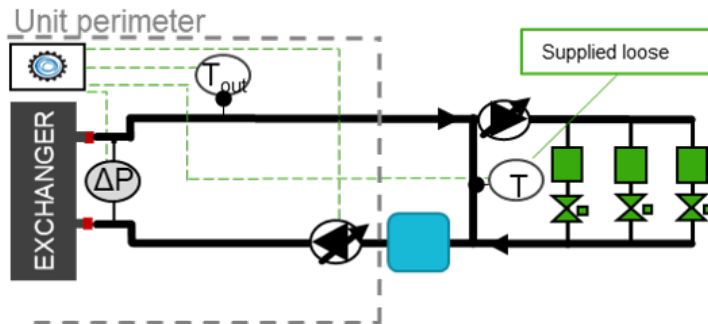

**FLOWZER VDT**

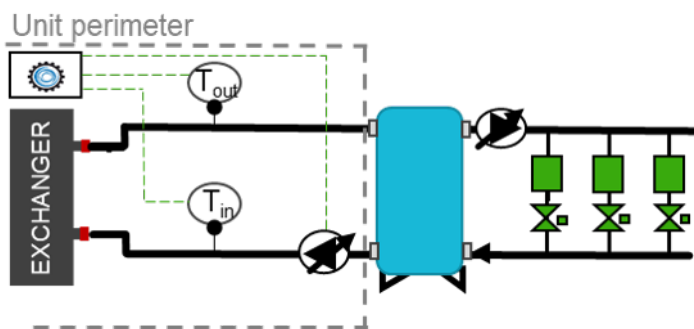

**FLOWZER VDT**

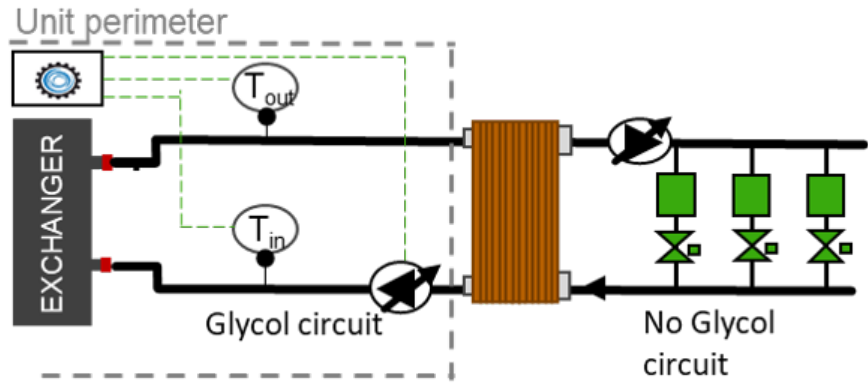

**FLOWZER VPS with DT-based control**

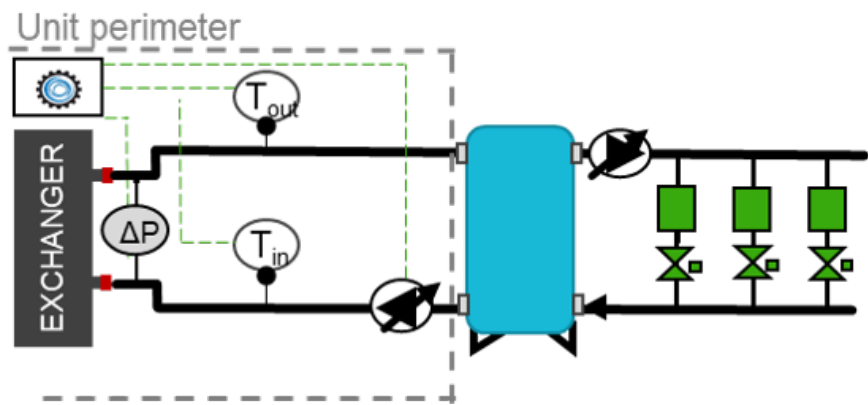

**FLOWZER VPS with DT-based control**

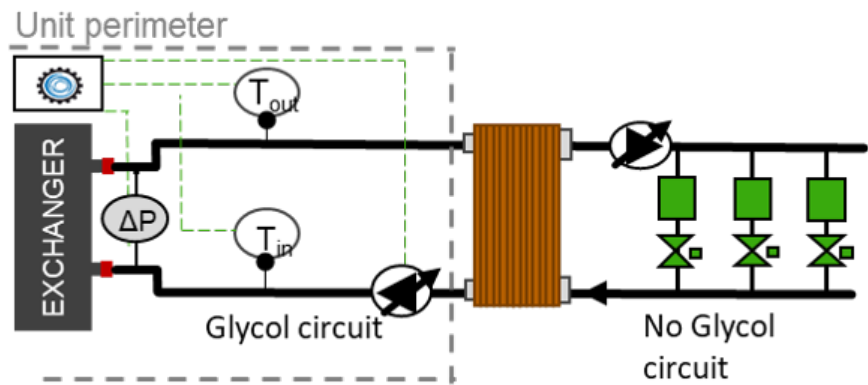

**FVD FLOWZER VD - control of available pump discharge head for variable flow systems without monitoring the flow rate limits;**

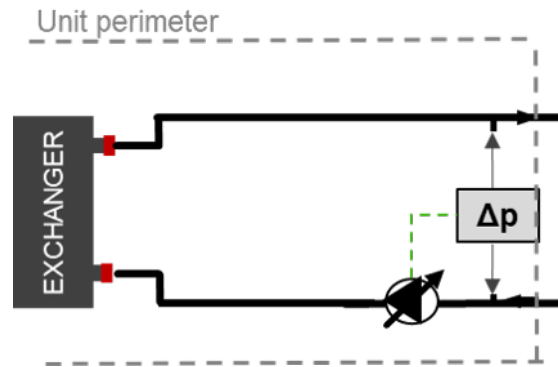

Flowzer VD requires two pressure transducers to be installed in the machine. Through these transducers, the inverter can gauge the actual pressure at the ends of the system and it can automatically adapt the pump speed to obtain a set available discharge head value. Flowzer VD must be combined with Flowzer VP. This accessory therefore allows a constant pressure system to be achieved.

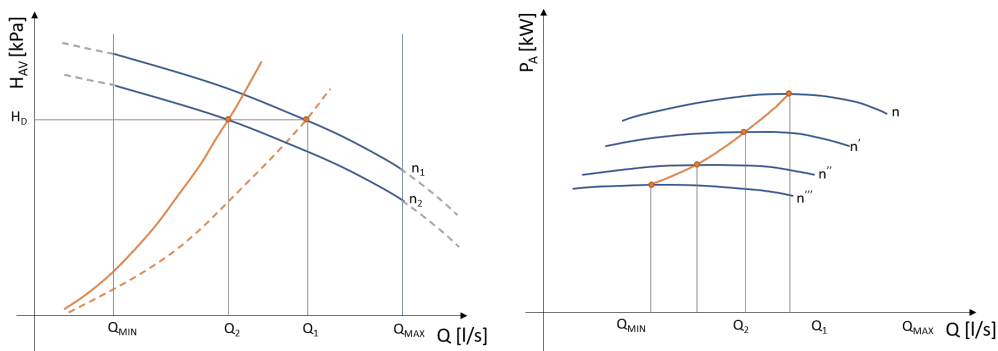

With the Flowzer VD, the customer can set, directly on the display, the available discharge head value ( $H_d$ ) that the unit must maintain. As can be seen from the graph as the user request decreases, the resistant curve of the plant moves to the left, consequently the inverter reduces the speed of the pump in order to maintain the useful head necessary for the unit. With this system a significant reduction in electrical power is achieved. The customer will have to check that, in minimum flow rate conditions (that is, with the maximum number of user points closed), this is always higher than or equal to the minimum flow rate allowed by the unit.

This accessory is useful when the total head losses of the circuit are slightly variable or when they change depending on the seasons (for example, some user points are active only during summer operation and not during winter operation).

The use of this accessory also allows the pump speed to be adapted to possible fouling of the filter on the hydraulic circuit.

The option is not compatible with the Multilogic version. Please refer to the HYZER solutions for the compatibility between variable flow systems and multi-machine systems.

**FVF FLOWZER VFPP - automatic management of variable flow rate in systems with one single primary circuit and a bypass valve;**

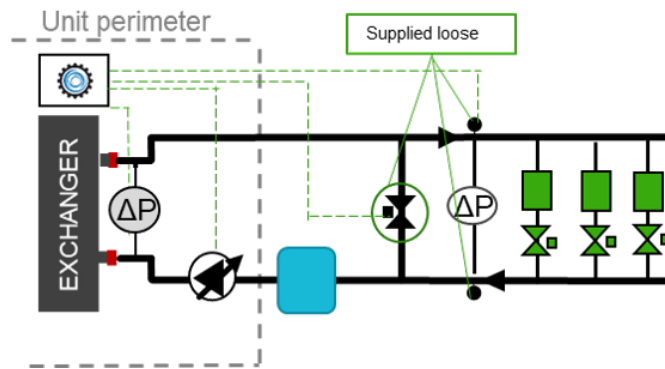

Bluethink solution for a variable flow rate system, consisting solely of a user-side primary circuit.

Flowzer VFPP includes:

- a pressure transducer installed at the ends of the user-side exchanger ( $\Delta p_e$ )
- a dedicated control system, installed at the factory in the electrical control panel of the unit ( $S_c$ )
- a modulating bypass valve with servo-motor supplied separately with it ( $V_{bp}$ ), supplied loose (installation by the customer)
- two system pressure transducers ( $\Delta p_p$ ) supplied separately (installation by the customer)

It is obligatory for the option to be combined with the Flowzer VP (inverter) and with one of the hydraulic modules that can be selected for the unit. The accessory is not compatible with Multilogic. Please contact our sales department for further details.

For single-circuit units in case of low system load (indicatively less than 50% of the nominal capacity of the unit at the given condition), the use of the variable flow rate may result in a greater oscillation of the supply water temperature than to a fixed flow management.

The option offers a complete default package to guarantee simple selection, purchasing and commissioning.

Flowzer VFPP has the advantage of:

- implementing an innovative design, which is alternative to the classic system based on fixed flow-rate primary circuit plus secondary circuit
- being ideal for new or entirely redesigned systems, especially for comfort applications
- having a variable flow system, with maximum energy saving
- simplifying the layout of the user circuit
- limiting the capex of the system
- performing a reliable check

The Flowzer VFPP system controller uses an advanced algorithm that enables prevention of unnecessary waste of energy and hunting by the inverter and the bypass valve.

---

The capex of the system is also reduced thanks to:

- single inverter + pumping module, integrated in the unit
- small internal footprint, due to the simplified layout

The operating principle can be summarized as follows:

- Flowzer VFPP carries out constant control of the discharge head
- the controller modulates the pump speed according to the signal detected by the system transducers  $\Delta p_p$
- as the demand from the system goes down, the pump speed will be reduced.
- the pump speed can be reduced until it reaches the minimum allowed flow rate on the heat exchanger of the unit
- this flow rate is indirectly monitored through the losses detected by the differential pressure transducer  $\Delta p_e$
- When the minimum allowed flow rate threshold is exceeded, the control system will open the bypass valve  $V_{bp}$  to recirculate the flow rate that is not required by the system, but is necessary to guarantee the minimum flow rate to the heat exchanger.

In the required minimum load condition (that is, with all system terminals switched off) the necessary minimum volume ( $V_{min}$ ) must be ensured by the relevant tank to be installed between the unit and the separator or the bypass pipe.

The bypass valve  $V_{bp}$  is controlled through a 0-10 V signal and must therefore be installed within 30 m of the unit.

The pressure transducers of the system  $\Delta p_p$  provide a 4-20 mA signal and require two 1/4" female fittings. These transducers must be installed within 200 m of the unit, near the system terminal that is affected by the highest line head losses or in any case in a position where it is possible to measure an adequate pressure value.

Further details can be found in the relevant manual.

**Variable flow system featuring primary circuit only**

	Application	Advantages	Disadvantages
<b>Flowzer VFPP</b>	Ideal for new systems intended to reduce installation costs	- Energy saving: the energy consumption during pumping operations can be cut down to 50% if compared with a traditional system Lower CAPEX thanks to reduced installation costs and smaller number of components (one pump less)	Requires some testing to correctly set the pressure available in the system and to correctly position the two transducers, based on the system layout and devices.
<b>Flowzer VD</b>	Ideal for systems fitted with changing users according to the season. Ideal for industrial processes, such as injection moulding, in order for each terminal to operate with the correct discharge head. It is recommended in structured systems in which the client has third-party systems to control the min. and max. flow rate.	- Plug&Play: provides for easy and flexible implementation as it is not supplied with options to be fitted therefore allows for quick commissioning.	A control is required by third-party equipment to ensure compliance with the unit flow limits.

**Flowzer VFPP**

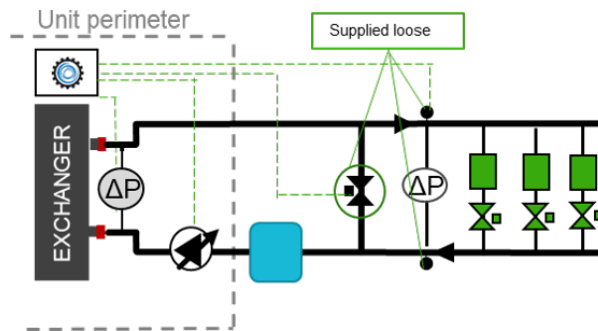

**Flowzer VD**

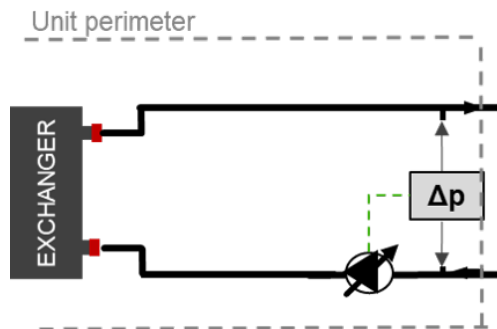

## HFx HYZER E VFPP function

The HYZER E VFPP function combines the Multilogic function, which is designed to manage multi-machine systems, with the FLOWZER VFPP control for variable flow systems.

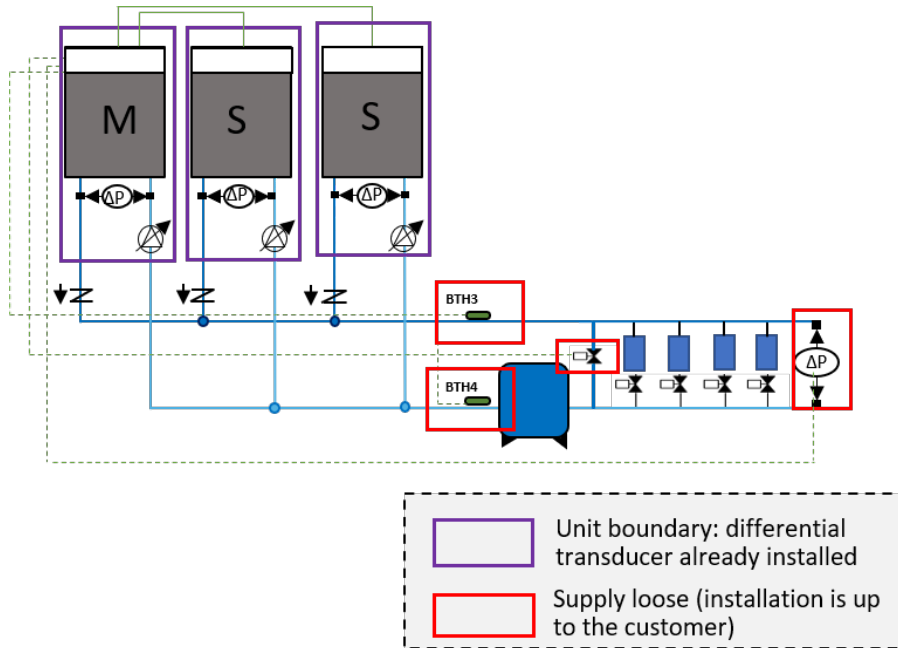

It is obligatory for the option to be combined with the Flowzer VP (inverter) and with one of the hydraulic modules that can be selected for the unit.

Units operate according to the Master/Slave logic that is typical of a Multilogic system. For additional details, please refer to the FMx option.

The HYZER E function requested with the unit can be:

- **HF0:** HYZER E VFPP function for Slave units;
- **HF2:** HYZER E VFPP function for the Master unit in order to manage up to 2 Slave units;
- **HF6:** HYZER E VFPP function for the Master unit in order to manage up to 6 Slave units.

If you need to connect more than 6 slaves (up to 31), you can ask for a quotation from our sales department.

For the slave units, the accessory includes:

- programming of the unit as slave of a system of machines in Multilogic network

For the master units, the accessory includes:

- programming of the unit as master of a system of machines in Multilogic network
- entering of the parameters necessary for connection with the individual slave units
- installation in the electrical control panel of a network switch to allow the units to be connected in a LAN network.
- the supply of 2 temperature probes to be positioned on the delivery and return manifold for system thermoregulation (supplied with the system - installation and wiring by the customer);
- the supply of two pressure transducers (supplied with the system - installation and wiring by the customer) to be installed near the system terminal that is affected by the highest head losses in the line or in any case in a position where it is possible to measure an adequate pressure value.
- The option also includes the supply of a bypass valve controlled by a 0-10 V signal, which must be selected in function of the system capacity. Please refer to the VBx options for correct selection.

The connection between the master unit and the slave units made with a CAT cable. 5E/UTP (prepared by the customer) with RJ45 connectors. Maximum cable length 100m.

For further details, please refer to the controller manual.

## VBx VFPP bypass valve for HYZER E

The option is supplied with the bypass valve, which is selected according to the system capacity.

This option must be selected with either the "HYZER E VFPP function for Master unit to manage up to 2 Slave units" or "HYZER E VFPP function for Master unit to manage up to 6 Slave units".

	System capacity range**	Quantity	Diameter	Qmax**
	kW	-	in	m <sup>3</sup> /h
<b>S_A</b>	<240	1	2 1/2"	41.3
<b>S_B</b>	240÷335	1	3"	57.6
<b>S_C</b>	335÷570	1	4"	98
<b>S_D</b>	570÷850	1	5"	146.2
<b>S_E</b>	850÷1250	1	6"	215
<b>S_F</b>	1250÷1700	2	2 x 5"	2 x 146.2
<b>S_G</b>	1700÷2500	2	2 x 6"	2 x 215

\*\* values based on a 5 °C temperature difference between the delivery and the return temperature

## HSx HYZER E VPS function

The HYZER E VPS function combines the Multilogic function, which is used to manage multi-machine systems, with the FLOWZER VPS control for variable flow systems.

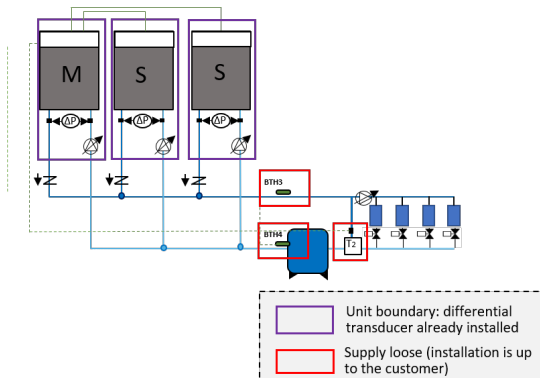

It is obligatory for the option to be combined with the Flowzer VP (inverter) and with one of the hydraulic modules that can be selected for the unit.

Units operate according to the Master/Slave logic that is typical of a Multilogic system. For additional details, please refer to the FMx option.

VPS control requires the installation on the machine of a differential transducer at the ends of the user-side heat exchanger in order to keep the flow rate in the system within a specific min. value allowed.

For additional details on the FLOWZER VPS logic, please refer to the dedicated FVPS option.

The networked units may be of different types, and the same observations as for the Multilogic option apply:

- if there are both chiller units and heat pumps in the network, the Master unit must obligatorily be one of the HP units;
- if there are both free-cooling and non free-cooling units in the network, the Master unit must obligatorily be one of the free-cooling units.

The HYZER E function requested with the unit can be:

- **HS0:** HYZER E VPS function for Slave units;
- **HS2:** HYZER E VPS function for the Master unit in order to manage up to 2 Slave units;
- **HS6:** HYZER E VPS function for the Master unit in order to manage up to 6 Slave units.

If you need to connect more than 6 slaves (up to 31), you can ask for a quotation from our sales department.

For the slave units, the accessory includes:

- programming of the unit as slave of a system of machines in Multilogic network

For the master units, the accessory includes:

- programming of the unit as master of a system of machines in Multilogic network
- entering of the parameters necessary for connection with the individual slave units
- installation in the electrical control panel of a network switch to allow the units to be connected in a LAN network.
- the supply of 2 temperature probes to be installed on the delivery manifold and on the bypass branch, which are typical of VPS control (supplied with the system - installation and wiring by the customer).

The connection between the master unit and the slave units made with a CAT cable. 5E/UTP (prepared by the customer) with RJ45 connectors. Maximum cable length 100m.

For further details, please refer to the controller manual.

## HDx HYZER E VPS with DT-based control function

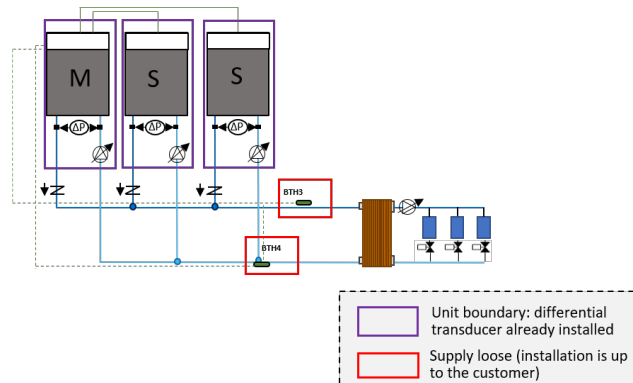

The HYZER E VPS with TD-based control function combines the Multilogic function, which is used to manage multi-machine systems, with the FLOWZER VPS with DT-based control control for variable flow systems.

It is obligatory for the option to be combined with the Flowzer VP (inverter) and with one of the hydraulic modules that can be selected for the unit.

Units operate according to the Master/Slave logic that is typical of a Multilogic system. For additional details, please refer to the FMx option.

VPS with DT-based control control requires the installation on the machine of a differential transducer at the ends of the user-side heat exchanger in order to keep the flow rate in the system within a specific min. value allowed.

For additional details on the FLOWZER VPS with TD-based control logic, please refer to the dedicated FVPS with DT-based control option.

The networked units may be of different types, and the same observations as for the Multilogic option apply:

- if there are both chiller units and heat pumps in the network, the Master unit must obligatorily be one of the HP units;
- if there are both free-cooling and non free-cooling units in the network, the Master unit must obligatorily be one of the free-cooling units.

The HYZER E function requested with the unit can be:

- **HD0:** HYZER E VPS with TD-based control function for Slave units;
- **HD2:** HYZER E VPS with TD-based control function for the Master unit in order to manage up to 2 Slave units;
- **HD6:** HYZER E VPS with TD-based control function for the Master unit in order to manage up to 6 Slave units.

If you need to connect more than 6 slaves (up to 31), you can ask for a quotation from our sales department.

---

For the slave units, the accessory includes:

- programming of the unit as slave of a system of machines in Multilogic network

For the master units, the accessory includes:

- programming of the unit as master of a system of machines in Multilogic network
- entering of the parameters necessary for connection with the individual slave units
- installation in the electrical control panel of a network switch to allow the units to be connected in a LAN network.

The connection between the master unit and the slave units made with a CAT cable. 5E/UTP (prepared by the customer) with RJ45 connectors. Maximum cable length 100m.

For further details, please refer to the controller manual.

### **PVX Variable flow setup for HYZER X**

The dedicated HYZER X controller is designed to manage the different units, devices and components that make up a hydronic system.

Systems featuring this controller require that the PVX option be installed at the ends of the user-side heat exchanger of a differential pressure transducer so that the machine is set up for variable flow rate control.

This option is mandatory in all units making up the system.

For additional information on the product HYZER X, please refer to the specific technical catalogue.

### **VIX Shut-off valves for systems with external pumps for HYZER X**

Systems featuring the HYZER X controller enable the selection of the shut-off valve used in systems that have an external pumping unit.

The option is always supplied separately from the unit and is for installation by the customer.

### **FLMX User-side flow meter for HYZER X**

Systems featuring the HYZER X controller enable the selection of the flow meter option to calculate the flow rate and the performances of the units.

The option is supplied with the system for installation on the user side (installation by customer).

---

## Electrical accessories

### A43N Power supply 400/3+N/50

The standard power supply of the unit

### CA Advanced control

The unit is supplied as standard with an advanced controller.

### LIID Limitation of the current absorbed by digital input

When this accessory is requested, a digital input is prepared in the terminal board to activate the forced capacity reduction of the unit to a set fixed level.

This accessory is useful when there is a need to necessarily limit the power absorbed by the unit as regards particular conditions.

We point out that, in some conditions (for example, during defrosting, oil return cycles or hourly compressor rotation procedures), the controller could force the unit to operate at full capacity for limited periods of time.

### CSP Set point compensation depending on external air temperature

For units fitted with this accessory, the set point of the unit is set so that it can vary between two values, a maximum and a minimum, depending on the external air temperature. The compensation ramp and the maximum and minimum values of the set point can be changed by the user.

Unless otherwise specified in the order, the controller will be set to implement a positive compensation logic according to the temperatures shown in the following diagrams:

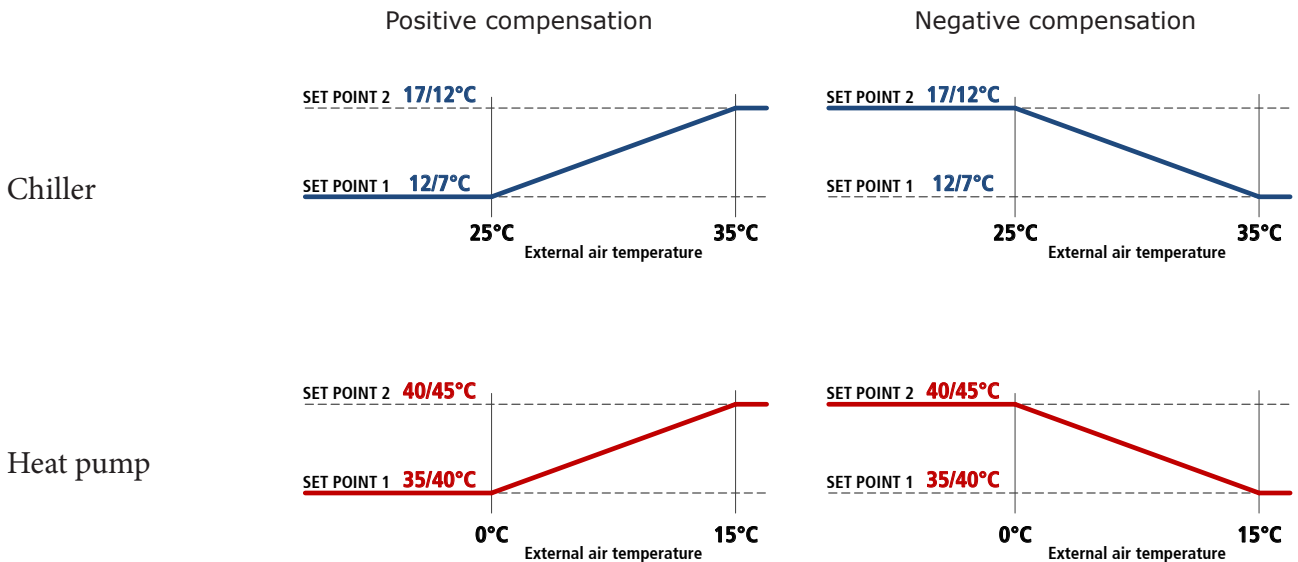

### SETD Double set point from digital input

The accessory allows you to preset two different operating set points and manage the change from one to the other through a digital signal.

The set point temperatures must be specified when ordering. For optimization of the unit, reference will be made to the lower set point in chiller mode and the higher set point in heat pump mode.

Unless otherwise specified in the order, the controller will be set at the factory with the following temperatures:

- in chiller mode, set point 1 to 7°C and set point 2 to 12°C
- in heat pump mode (only for HP units) set point 1 to 45°C and set point 2 to 40°C

---

**SETV Variable set point with remote signal**

The accessory allows the set point to be varied continuously between two preset values, a maximum and a minimum, depending on an external signal that can be of the 0-1V, 0-10V or 4-20mA type.

The set point temperatures and the type of signal to use for the adjustment must be specified when ordering. For optimization of the unit, reference will be made to the lower set point in chiller mode and the higher set point in heat pump mode.

Unless otherwise specified in the order, the controller will be set at the factory with 0-10V analogue input and with the following temperatures:

- in chiller mode, 0V will correspond to a set point of 7°C and 10V will correspond to a set point of 12°C
- in heat pump mode (only for HP units), 0V will correspond to a set point of 45°C and 10V will correspond to a set point of 40°C

If the difference between the minimum set point and the maximum set point is greater than 5K, it is compulsory to ask for the accessory "Electronic expansion valve".

**CP Single potential free operating contacts**

For units fitted with this accessory, there are clean contacts available on the terminal board inside the electrical box from which the customer can acquire signals that show the status of the unit's components (compressors, fans, pumps, alarms).

**TERM Remote-controlled user terminal panel**

This accessory allows the terminal normally situated on the machine to be replicated on a support situated at a distance. It is particularly suitable when the unit is placed in an area that is not easily accessible.

The accessory is supplied loose and is to be installed by the customer at a maximum distance of 120m from the unit. We advise using a cable of the following type: "TECO O.R. FE 2x2xAWG24 SN/ST/PUR".

For this accessory, there is a dedicated serial port.

**RE1P Relay for management of 1 external pump**

This accessory can be requested for units without pumps and allows a pump outside the machine to be controlled.

**RE2P Relay for management of 2 external pumps**

This accessory can be requested for units without pumps and allows two pumps outside the machine to be controlled with a running/stand-by logic by implementing a rotation on the hours of operation.

The two pumps are controlled by two separate relays.

**RMMT Maximum and minimum voltage relay**

This accessory constantly monitors the voltage value and the unit's power supply phase sequence. If the supply voltage does not fall within the set parameters or there is a phase reversal, an alarm is generated that stops the machine to prevent damage to its main parts

**IAVA Automatic circuit breakers**

With this accessory, automatic circuit breakers are installed instead of fuses for the protection of auxiliary loads and fans.

---

**SQE Heater for electrical control panel**

Electric heaters are positioned inside the electrical control panel and these prevent the formation of ice or condensation inside it.

**ARU Stopping of the unit due to temperatures below the operating limit**

This option is standard.

With this accessory, it is possible to set the unit so that the controller switches off the compressors when the unit is operating in heat pump mode and the external air temperature falls below a minimum set limit: this will prevent the unit from going into low pressure alarm, so avoiding having to manually restart the machine. When the external air temperature returns above the set threshold temperature, the unit will automatically resume operation without it being necessary to do anything.

For units equipped with integrated pump, the pump will always be kept running so as to prevent ice formation and ensure correct reading of the temperature and antifreeze safety probes at all times.

The stopping temperature must be set based on the set point temperature and in accordance with what is allowed by the operating limits of the machine.

**NSS Night Shift System**

In the day time slot, which is normally the one with the highest thermal load, priority is given to efficiency and therefore the machine operates with a fan regulation curve that maximizes the EER. In the night time band (or in any case from time band decided by the customer), the priority changes to limiting the noisiness of the machine and therefore the controller carries out an adjustment of the control ramp of the condensing fans, thereby reducing the air flow rate and consequently the noise emission level. So, in this time band, the unit is a super low noise machine (equivalent to SLN). In any case, if there is a need for additional cooling capacity, the controller will manage the demand, if necessary, by accelerating the fans and keeping condensation within the correct operating limits. The time slots can be set from the control depending on installation requirements. When the unit is working in heat pump mode, in order to maximise the COP and to obtain the widest possible operating limits, the control of the unit forces the fans to the maximum speed also during the night time bands.

---

**ENM Energy meter**

The accessory allows the main electrical quantities (including voltage, current, power) to be read on the three phases, via current transformer.

This accessory communicates with the BlueThink controller to supervise the monitored data. The values measured are then made available through the unit display and the web server.

**ENML Energy meter with current limiter**

The accessory allows the main electrical quantities (including voltage, current, power) to be read on the three phases, via current transformer.

This accessory communicates with the BlueThink controller to supervise the monitored data. The values measured are then made available through the unit display and the web server.

This accessory is designed to limit the maximum current the unit can absorb. The controller instantly checks the absorption levels and, where necessary, it applies a forced capacity reduction that keeps the absorbed current value below the stored threshold.

**ENT Energy trend**

This function estimates the energy consumption and the cooling and heating production of the unit. The efficiency of the unit is calculated ("EER" for cooling operation or "COP" for heating operation).

Data are calculated in real time according to the working conditions of the unit (evaporation and condensing pressure, external air temperature).

Data are also displayed in the unit user interface in a dedicated "Energy Trend" mask.

Following data are also recorded in the logs in the controllers memory:

- "EnergyTrendHours" contains records of the values of energy absorbed and produced for each hour
- "EnergyTrendHistory" contains records of the values of energy absorbed and produced for each day

The "logs" can then be downloaded via a USB pendrive or from the WEB pages.

The function returns values within the operating envelope of the machine. No data will be recorded outside the operating envelope. The data is stored as an hourly average for 12 months of operation. After 12 months the control overwrites the first data. If hourly resolution is required, the data must be downloaded at least once a year. The control also stores daily average data. This is stored for the life of the unit. In case of microprocessor board failure, data, if not previously downloaded and saved, will be lost.

## AS Automatic management of domestic hot water

This function enables the unit to control the temperature inside a domestic hot water storage tank and to manage a 3-way valve outside the unit (available as an accessory).

The water temperature in the domestic hot water tank is controlled through a dedicated probe situated in the tank.

Normally, the heat pump operates on the system to meet the comfort requirements of the building, but when the water temperature in the domestic hot water tank falls below a set threshold, the controller switches to domestic hot water production.

If the unit is operating as heat pump for heating, the 3-way valve will be switched and the set point changed. On the other hand, if the unit is producing chilled water for air conditioning, the controller switches the unit to heat pump mode, gives it the set point for domestic hot water and turns the 3-way valve to the appropriate position. Once the temperature in the domestic hot water tank has reached the set value, the unit automatically returns to producing water for the heating or air conditioning system.

When there is a defrost request, the 3-way valve is always forced to position itself on the system, whatever operating mode it may be in.

Domestic hot water production is always given priority.

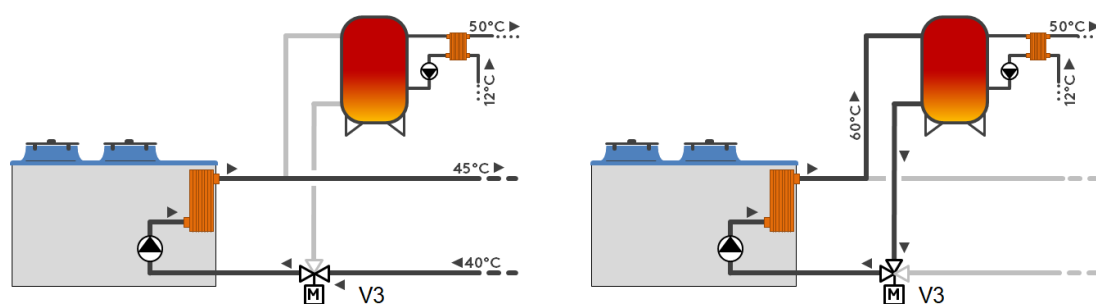

With this accessory there are two digital inputs in the electrical control panel for respectively deactivating domestic hot water production and the production of water for the heating/air conditioning system.

When the unit is working in "domestic hot water only" mode, the pump is normally off and is switched on only for the time required to meet the demand for domestic hot water production.

When this accessory is fitted, the machine must have control of pump operation. This means that either the unit is equipped with one of the hydronic modules available in the catalogue (therefore with at least one pump installed on it) or the relay for external pump management must be requested as accessory.

The probe to be fitted in the domestic hot water tank is supplied with the unit with a 5m long cable. The probe is used to measure the water temperature in the hottest part of the tank, so it must be positioned in a specially prepared pocket and secured using heat conducting paste. Installation by the customer.

In case of management with variable water flow, the installation must necessarily be made with the derivation towards the domestic hot water tank upstream of any bypass valve or channel.

---

**CSU Enabling for integration heater on user side**

The accessory enables management of a heat source outside the unit which is supplementary to the user circuit.

The necessary OK signals for controlling a maximum of four capacity steps are included in the electrical control panel. Activation of the steps takes place depending on the distance from the set heat pump set point.

**CSS Enabling for integration heater on tap water side**

The accessory enables management of a heat source outside the unit which is supplementary to the domestic hot water circuit.

**SV3 Signal for 3-way modulating valve**

(for HP units)

In the electrical control panel, a 0-10V output is preset to be used to control a 3-way modulating valve inserted on the hot circuit.

If the temperature of the water entering the hot exchanger is too low (for example, after the machine has been stopped for an extended period), through this signal, the controller of the unit will control the valve so as to recirculate part of the flow rate at the outlet and ensure that the unit always works within the operating limits.

The 3-way modulating valve is not included in this accessory, but can be requested as further accessory.

---

## Network accessories

---

### **PBA BACnet protocol over IP (Ethernet)**

The controller is set for use, in read and write mode, of the BACnet port on IP protocol.

By default, the programming gives read-only access to the control of the unit. Reading / writing access is activable on field with a service level.

### **PSN SNMP protocol**

The accessory consists of a gateway that allows Ethernet connection to a SNMP manager supervision system.

The use of this accessory causes the RS485 serial port to be unavailable.

### **GLO Modbus Lonworks Gateway**

With this accessory, a RS485/Lon gateway is installed inside the electrical control panel.

By default, the programming gives read-only access to the control of the unit. Reading / writing access is activable on field with a service level.

### **SMAR Smartlink function predisposition**

This accessory makes it possible to connect the controller of the unit with the controller of a Swegon GOLD™ air handling unit via a simple serial cable, so allowing their operating logics to be merged into a single consciousness that pursues the maximum energy efficiency of the system. The RS485 serial interface is already included and dedicated to connection with Swegon units.

The option is incompatible with:

- double set point
- variable set point with remote signal
- summer/winter selection by digital input
- set point compensation depending on external air temperature
- multilogic
- all communication protocols.

### **SMAP Setup of Smartlink+ functions**

This option is used to connect the controller in the unit with the controller of a Swegon GOLD™ air handling unit via the Ethernet port TCP/IP, so allowing the operating logics of hydronic and ventilation systems to be merged into a single logic for the achievement of maximum energy efficiency and comfort. This option is only available for units featuring an advanced controller and it is compatible with Multilogic and Hyzer systems only if the machine is the Master.

The option is incompatible with:

- double set point
- variable set point with remote signal
- set point compensation depending on external air temperature
- all communication protocols.

## FMx Multilogic Function

The Multilogic function allows management of up to 32 units equipped with advanced Bluethink controller and connected in hydraulic parallel with each other.

Multilogic systems only operate with the "Ipro" advanced controller and if the connected units have the same software version. A Multilogic network cannot operate with different software versions/releases.

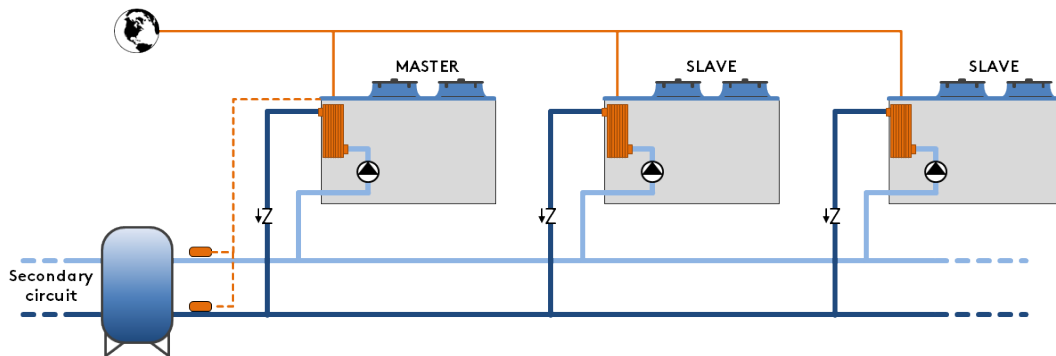

On the basis of the information recorded by the temperature probes installed on the delivery and return manifolds of the system, with the master unit, a capacity request is generated that is distributed among the units connected in the Multilogic network according to settable priority and optimization logics.

If communication between the units fails or if the master is off-line, the slave units can continue to work according to the set thermoregulation parameters.

The connected units can be different from each other, in terms of capacity and set-up, provided the following rules are complied with:

- if there are both chiller units and heat pumps in the Multilogic network, the Master unit must obligatorily be one of the HP units
- if there are both free cooling and non free-cooling units in the Multilogic network, the Master unit must obligatorily be one of the free-cooling units.

The Multilogic function that can be requested with the unit can be:

- **FM0:** Multilogic function for Slave unit
- **FM2:** Multilogic function for Master unit for managing up to 2 Slaves
- **FM6:** Multilogic function for Master unit for managing up to 6 Slaves

If you need to connect more than 6 slaves (up to 31), you can ask for a quotation from our sales department.

For the slave units, the accessory includes:

- programming of the unit as slave of a system of machines in Multilogic network

For the master units, the accessory includes:

- programming of the unit as master of a system of machines in Multilogic network
- entering of the parameters necessary for connection with the individual slave units
- installation in the electrical control panel of a network switch to allow the units to be connected in a LAN network.
- the supply of 2 temperature probes to be positioned on the delivery and return manifold of the system (supplied separately with it, installation and wiring by the customer)

The connection between the master unit and the slave units made with a CAT cable. 5E/UTP (prepared by the customer) with RJ45 connectors. Maximum cable length 100m.

For further details, please refer to the controller manual.

## BEET Blueye® via Ethernet

**Blueye®** is a supervision platform that enables remote monitoring of one or more units in the same system interconnected through a network with Modbus protocol.

This accessory features the Blueeye device, as already installed and wired in the unit.

The critical variables to be monitored over time are identified for each connected device. These variables are sampled and saved to the cloud so that they are accessible at all times through a web portal or a mobile APP (available for Android and iOS).

The following options can be selected for connection to the internet:

- a LAN (Ethernet) connection - available in the system;
- a connection to a mobile network - at least 3G. The data SIM card is not included.

Three different types of contracts can be signed.

### **Blueye® Cloud Basic:**

- to monitor a max. of 20 variables in total over max. 5 units/peripherals;
- to set a min. sampling frequency of 60 seconds.

### **Blueye® Cloud Advanced:**

- to monitor a max. of 200 variables in total over max. 10 units/peripherals;
- to set a min. sampling frequency of 5 seconds.

### **Blueye® Connect:**

- To monitor up to 10 units/peripherals.

Subscribing to any of the **Blueye® Cloud** enables:

- viewing the history of the monitored variables, in the form of both numerical values and graphs;
- downloading the history of variables in CSV format;
- the creation of automatic reports;
- setting notifications (via APP or mail) with settable thresholds for each variable;
- switching the unit ON/OFF remotely;;
- changing the set point remotely;
- selection of SUMMER/WINTER mode remotely (for reversible units only).

The subscription to the **Blueye® Connect** service offers the advantages below:

- a safe connection (tunnelling) between the user and the remote unit through the Blueeye® portal;
- full access to the remote controller;
- real time monitoring;
- software upgrading.

**Blueye® via Ethernet** is only available for units supplied with an advanced controller and does not include any type of service. This service must be purchased separately based on the number of units/devices to be connected and the number of variables to be monitored. In order to connect multiple units to **Blueye® device, the network switch is required (this accessory is sold separately).**

**Units can also be connected to the Blueeye device through the RS485 network featuring a Modbus RTU protocol (for this option, refer to BERS accessory).**

**For further details, refer to the specific Blueeye® documentation.**

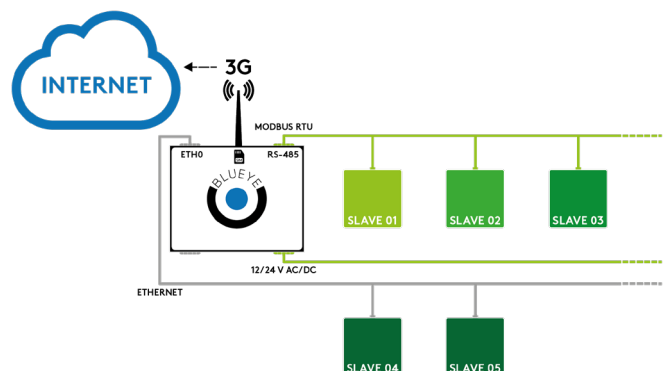
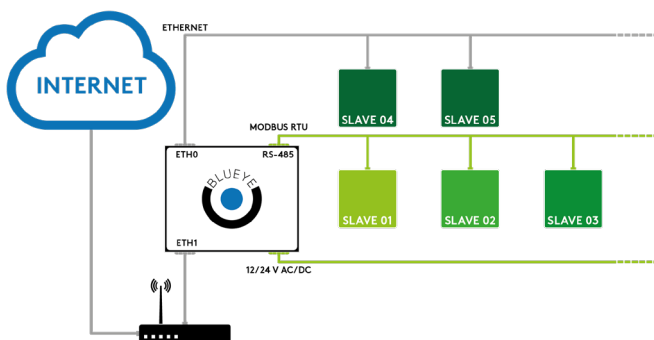

---

### SW4P Network switch with 4 ports

The accessory includes installation in DIN rail of a professional 4-port network switch. Requires Blueye via Ethernet.

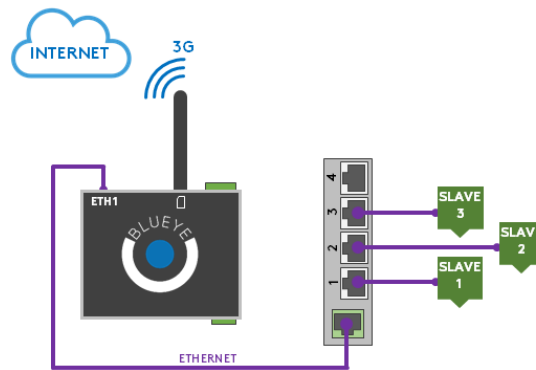

### SW8P Network switch with 8 ports

The accessory includes installation in DIN rail of a professional 8-port network switch. Requires Blueye via Ethernet.

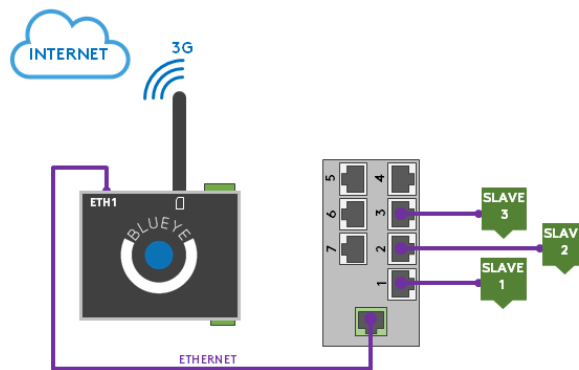

### PBL Predisposition for connection to BoosterLink

(for HP units)

Predisposition for connection of the source unit to the BoosterLink manager, in combination with a user-side unit of the "temperature booster" type.

For further information on use, refer to the specific documentation.

---

## Other accessories

---

### **AG Rubber anti-vibration mounts**

These allow you to reduce the vibrations transmitted from the unit to the surface it is standing on. Accessory supplied loose.



### **AM Spring anti-vibration mounts**

These allow you to reduce the vibrations transmitted from the unit to the surface it is standing on. Accessory supplied loose.



### **RAT Anti-intrusion nets**

An arc-welded, painted net (RAL colour 7035) is installed to close off the external openings so as to prevent access to the technical compartment by unauthorized personnel.



### **SLIT Special pallet/skid for container shipment**

The unit is placed on a skid that makes the container loading and unloading operations easier. The accessory is mandatory if shipping by container is required

### **STL Brackets for transport over long distances**

The accessory consists of adding reinforcing bars to the structural metalwork. This allows the strength of the structure to be increased for long distance road transport.

---

## **MCHE E-coated microchannel coil**

(for chiller unit)

The e-coated microchannel coils are treated by immersion of the whole exchanger in an emulsion of organic resins, solvents, ionic stabilisers and deionised water. This is all subjected to a suitable electric field that causes the formation of a solid, uniform deposit on the exchanger. The function of this deposit will be to protect the aluminium from corrosion without penalising its thermophysical properties.

Protective treatment of the exchanger is strongly recommended if at least one of the points below is verified:

- there are obvious signs of corrosion of the exposed metal surfaces in the installation area
- the installation is located close to the sea coast
- the prevailing winds come from the sea towards the unit
- the environment is industrial with a significant concentration of pollutants
- the environment is urban with a high population density
- the environment is rural with the presence of organic discharges and effluents.

**With reference to the protection criteria to follow, especially for installations close to the coast, refer to the section titled "Installations that require the use of treated coils".**

## **IDRO Coil pack with hydrophilic coating**

This option is standard in HP units.

Hydrophilic coating is a special treatment applied to the finned coils (source side) in heat pump units to facilitate drainage of the condensate that forms on the surface of the heat exchanger.

This treatment causes the water vapour to form a film of condensate on the surfaces of the fins, which, thanks to the low surface tension, drains rapidly into the drip tray (if present) positioned beneath the coils.

Compared to traditional finned coils in untreated aluminium, the hydrophilic coating delays the necessity to defrost the heat exchanger, thereby extending the interval between defrosting cycles and boosting its efficiency and, hence, improving the performance and energy consumption of the heat pump.

In the absence of the hydrophilic coating, the humidity present in the air condenses in the form of drops, which, due to the greater friction, are more likely to remain trapped within the coil pack, limiting the passage of air and impacting negatively on heat exchange, this causes the surface temperature to drop further (due to a decrease in the evaporation temperature), facilitating the formation of ice and reducing the interval between defrosting cycles. This effect is even more pronounced in the case of installations in particularly windy areas.

The following is a comparison between a standard finned coil pack and a pack treated with the hydrophilic coating at the end of the defrosting cycle, on the same unit, with an external DB air temperature of  $-2^{\circ}\text{C}$ . Note the residual presence of water droplets on the untreated heat exchanger, as compared to perfectly clean surface of the treated unit.



Standard, untreated coil pack

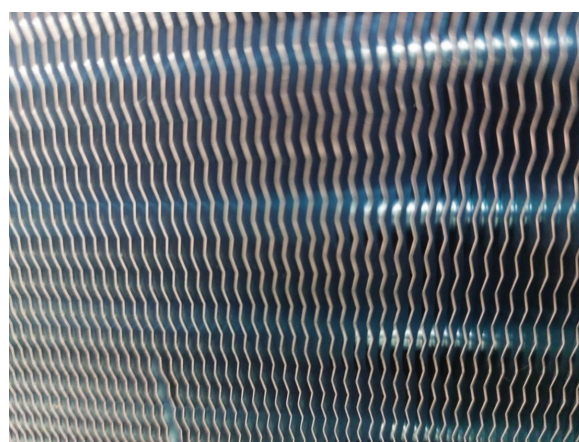

Coil pack with hydrophilic coating

While it is not specifically designed for use in marine environments, an additional advantage of the hydrophilic coating is its greater resistance to salt fog conditions with respect to untreated aluminium.

To avoid compromising the benefits of applying the treatment, or prevent additional problems from arising in the case of untreated units, it is also necessary to ensure the condensed water is drained correctly, so as to prevent the formation of ice at the base of the heat exchanger, which could cause it to extend to the entire coil pack, compromising the efficiency of the defrosting cycle, and hence the operation and performance of the unit.

With this in mind, the following accessories are available:

- VASC\_condensate drip tray (available either as standard or optional, depending on the series/model of the unit)
- RAV\_anti-freeze element (available either as standard or optional, depending on the series/model of the unit)
- RAM\_high power anti-freeze element
- KTC\_drip tray connector tube kit (for units equipped with drip tray)

The hydrophilic coating is not compatible with other treatments included in the price list.

---

**RAAL Cu/Al coils**  
(for chiller unit)

This accessory uses finned pack coils with copper tubes and aluminium fins instead of microchannel coils.

**ALPR Pre-painted aluminium coil**

This option uses finned pack coils with copper tubes and pre-painted aluminium fins.

**ANTC Coil treated with anti-corrosion paints**

The treatment is applied to the finned pack coils with copper pipes and aluminum fins and consists in the passivation of the aluminum with a polyurethane base through a procedure of immersion and then of a spray application of the coating that guarantees a double protection of the finning all over the exposure to the most aggressive environmental conditions even for more particular (or niche) process applications.

Specifically, the immersion process guarantees complete coverage of galvanic corrosion while the application of the spray protects the ends of the fins which represent the critical point for the initiation of the corrosion phenomenon.

For chiller units, this accessory also includes the "Cu/Al coil" accessory.

**With reference to the protection criteria to follow, especially for installations close to the coast, refer to the section titled "Installations that require the use of treated coils".**

---

**VASC Condensate drip tray**

This option is standard in HP units.

This accessory can be combined with HP units in order to collect the condensate that forms after each coil defrost cycle. The tray is made of steel and is placed under the source-side heat exchanger, at a suitable distance.

On the opposite sides of the tray, there are some 1" close nipples to allow the customer to connect a pipe to it for draining out the water so as not to cause harm or damage to people or objects.

**RAV Anti-freeze heater for condensate drip tray**

This option is standard in HP units.

A heating cable, glued to the bottom, can be combined with the condensate drip tray to prevent ice formation at the base of the coil or near the drains.

The heater is controlled by a thermostat and is activated depending on the external air temperature.

Recommended accessory for installations in cold regions.

**RAM Antifreeze oversized heater for condensate drip tray**

The unit is fitted as standard with a heating cable glued to the bottom of the condensate tray to prevent formation of ice.

RAM accessory provide an oversized electrical heaters system.

Heaters are managed with a thermostat , activated depending on outside air temperature.

If the unit is designed to work as sizing point or as prolonged operating condition in this area then RAM accessory is mandatory. If the unit will be rarely having this working condition with for example cold winds then it's recommended base on local assessment.

**KTC Condensate drain pan connection pipes kit**

Pipes for draining water collected in the condensate drain tray.

They are supplied in a separate kit to be assembled and connected on site.

Electrical heating resistances are provided inside the drain pan with an additional length to properly cover the needed part of the drain pipe as well.

# TECHNICAL SPECIFICATIONS

## TITAN Zero Hi

			23.2	26.3	30.2	33.2	36.2	40.2
<b>Cooling</b>								
Refrigeration capacity	(1)	kW	228.4	256.9	292.9	331.9	356.7	398.4
Total absorbed power	(1)	kW	81.5	91	108.9	122.3	137.5	161.4
EER	(1)		2.8	2.82	2.69	2.71	2.59	2.47
<b>Compressors</b>								
Compressors/Circuits		n°	2/2					
Minimum capacity reduction step	(7)	%	23					
Refrigerant charge CH (MCHX)	(3)	kg	-					
Refrigerant charge CH (Cu/Al)	(3)	kg	26.16	28.65	33.98	37.28	40.13	44.33
<b>Fans</b>								
Quantity		n°	6			8		
Total air flow rate CH (MCHX)		m³/h	123000			164000		
<b>User-side heat exchanger</b>								
Quantity		n°	1					
Water flow rate CH	(1)	m³/h	39.3	44.2	50.4	57.1	61.4	68.5
Pressure drop CH	(1)	kPa	21	25	29	22	25	27
<b>Noise levels</b>								
Sound power level cooling	(4)	dB(A)	92			93		94
Sound pressure level cooling	(6)	dB(A)	59			61		62
<b>Dimensions and weights**</b>								
Length		mm	5085					
Depth		mm	2250					
Height		mm	2475					
Operating weight		kg	3488	3530	3680	3784	3814	3878

CH: chiller unit; HP: heat pump unit; MCHX: unit with microchannel coils

(1) External air temperature of 35°C and user-side heat exchanger water inlet-outlet temperature of 12-7°C. Values compliant with standard EN 14511

(2) Outside air temperature 7°C DB, 6°C WB; condenser inlet/outlet water temperature 40/45°C. Values compliant with standard EN 14511

(3) Theoretical values referred to the basic unit. The amount of gas actually charged in the unit may differ.

(4) Unit operating at rated capacity, with no accessories of any kind - external air temperature 35°C and water input/output temperature from/to heat exchanger and user equal to 12/7°C. Values taken by measurements made in accordance with standard ISO 3744 and the Eurovent certification programme, where applicable. Binding values See NOISE LEVELS section.

(5) unit operating at nominal operating capacity, with no accessories of any kind, with external air temperature of 7°C (6°C WB) and user-side heat exchanger water inlet/outlet temperature of 40/45°C. Values obtained from measurements carried out in accordance with standard ISO 3744.

(6) Values obtained from the sound power level (conditions: note 4), related to a distance of 10 m from the unit in free field with directivity factor Q=2. Non-binding values See NOISE LEVELS section.

(7) Approximate value. The minimum capacity reached by the unit depends on the operating conditions. The value shown may not be suitable for calculating the minimum volume of water: to do this, consult the "Minimum water content in the system" section.

(8) Former Eurovent's seasonal efficiency index. Value not certified by Eurovent from 2019. Reference: base unit, without any accessories

\*\* Basic unit without included accessories

The certified standard performances and data can be verified in <https://www.eurovent-certification.com>

Some voluntary data are not certified (i.e. Noise Level for water source units; SCOP for units with Pdesign >70 KW; SCOP MT values).

## TITAN Zero Hi SLN

			23.2	26.3	30.2	33.2	36.2	40.2
<b>Cooling</b>								
Refrigeration capacity	(1)	kW	219.6	246.5	282.8	318.7	339.6	377.1
Total absorbed power	(1)	kW	81.7	91.7	108.9	123	138.8	163.8
EER	(1)		2.68	2.69	2.6	2.59	2.45	2.3
<b>Compressors</b>								
Compressors/Circuits		n°	2/2					
Minimum capacity reduction step	(7)	%	23					
Refrigerant charge CH (MCHX)	(3)	kg	-					
Refrigerant charge CH (Cu/Al)	(3)	kg	26.16	28.65	33.98	37.28	40.13	44.33
<b>Fans</b>								
Quantity		n°	6			8		
Total air flow rate CH (MCHX)		m³/h	123000			164000		
<b>User-side heat exchanger</b>								
Quantity		n°	1					
Water flow rate CH	(1)	m³/h	37.8	42.4	48.7	54.9	58.4	64.9
Pressure drop CH	(1)	kPa	19	24	27	20	23	24
<b>Noise levels</b>								
Sound power lev. SLN vers.	(4)	dB(A)	90			91		92
Sound pressure lev. SLN vers.	(6)	dB(A)	57			59		60
<b>Dimensions and weights**</b>								
Length		mm	5085					
Depth		mm	2250					
Height		mm	2475					
Operating weight		kg	3488	3530	3680	3784	3814	3878

CH: chiller unit; HP: heat pump unit; MCHX: unit with microchannel coils

- (1) External air temperature of 35°C and user-side heat exchanger water inlet-outlet temperature of 12-7°C. Values compliant with standard EN 14511
- (2) Outside air temperature 7°C DB, 6°C WB; condenser inlet/outlet water temperature 40/45°C. Values compliant with standard EN 14511
- (3) Theoretical values referred to the basic unit. The amount of gas actually charged in the unit may differ.
- (4) Unit operating at rated capacity, with no accessories of any kind - external air temperature 35°C and water input/output temperature from/to heat exchanger and user equal to 12/7°C. Values taken by measurements made in accordance with standard ISO 3744 and the Eurovent certification programme, where applicable. Binding values See NOISE LEVELS section.
- (5) unit operating at nominal operating capacity, with no accessories of any kind, with external air temperature of 7°C (6°C WB) and user-side heat exchanger water inlet/outlet temperature of 40/45°C. Values obtained from measurements carried out in accordance with standard ISO 3744.
- (6) Values obtained from the sound power level (conditions: note 4), related to a distance of 10 m from the unit in free field with directivity factor Q=2. Non-binding values See NOISE LEVELS section.
- (7) Approximate value. The minimum capacity reached by the unit depends on the operating conditions. The value shown may not be suitable for calculating the minimum volume of water: to do this, consult the "Minimum water content in the system" section.
- (8) Former Eurovent's seasonal efficiency index. Value not certified by Eurovent from 2019. Reference: base unit, without any accessories

\*\* Basic unit without included accessories

The certified standard performances and data can be verified in <https://www.eurovent-certification.com>

Some voluntary data are not certified (i.e. Noise Level for water source units; SCOP for units with Pdesign >70 KW; SCOP MT values).

## TITAN Zero Hi HP

			23.2	27.2	30.2	33.2	38.2	42.2
<b>Cooling</b>								
Refrigeration capacity	(1)	kW	215.7	239.7	277.5	310.4	330.6	366.6
Total absorbed power	(1)	kW	85.3	95.7	113.5	128.2	144	170
EER	(1)		2.53	2.5	2.44	2.42	2.3	2.16
<b>Heating</b>								
Heating capacity	(2)	kW	232.5	254.2	301.9	331.1	355.8	393.7
Total absorbed power	(2)	kW	80.7	86.9	108.3	116.2	128	147
COP	(2)		2.88	2.92	2.79	2.85	2.78	2.68
<b>Compressors</b>								
Compressors/Circuits		n°	2/2					
Minimum capacity reduction step	(7)	%	23					
Refrigerant charge HP	(3)	kg	26.2	28.6	34	37.3	40.1	44.3
<b>Fans</b>								
Quantity		n°	6			8		
Total air flow rate HP		m³/h	117984			157312		
<b>User-side heat exchanger</b>								
Quantity		n°	1					
Water flow rate CH	(1)	m³/h	37.1	41.2	47.7	53.4	56.9	63.1
Pressure drop CH	(1)	kPa	18	20	25	18	21	22
Water flow rate HP	(2)	m³/h	39.9	43.7	51.8	56.9	61.2	67.6
Pressure drop HP	(2)	kPa	22	25	30	23	27	29
<b>Noise levels</b>								
Sound power level cooling	(4)	dB(A)	92		93		94	
Sound pressure level cooling	(6)	dB(A)	59		61		62	
<b>Dimensions and weights**</b>								
Length		mm	5085					
Depth		mm	2250					
Height		mm	2475					
Operating weight		kg	3488	3530	3680	3784	3814	3878

CH: chiller unit; HP: heat pump unit; MCHX: unit with microchannel coils

- (1) External air temperature of 35°C and user-side heat exchanger water inlet-outlet temperature of 12-7°C. Values compliant with standard EN 14511
- (2) Outside air temperature 7°C DB, 6°C WB; condenser inlet/outlet water temperature 40/45°C. Values compliant with standard EN 14511
- (3) Theoretical values referred to the basic unit. The amount of gas actually charged in the unit may differ.
- (4) Unit operating at rated capacity, with no accessories of any kind - external air temperature 35°C and water input/output temperature from/to heat exchanger and user equal to 12/7°C. Values taken by measurements made in accordance with standard ISO 3744 and the Eurovent certification programme, where applicable. Binding values See NOISE LEVELS section.
- (5) unit operating at nominal operating capacity, with no accessories of any kind, with external air temperature of 7°C (6°C WB) and user-side heat exchanger water inlet/outlet temperature of 40/45°C. Values obtained from measurements carried out in accordance with standard ISO 3744.
- (6) Values obtained from the sound power level (conditions: note 4), related to a distance of 10 m from the unit in free field with directivity factor Q=2. Non-binding values See NOISE LEVELS section.
- (7) Approximate value. The minimum capacity reached by the unit depends on the operating conditions. The value shown may not be suitable for calculating the minimum volume of water: to do this, consult the "Minimum water content in the system" section.

\*\* Basic unit without included accessories

The certified standard performances and data can be verified in <https://www.eurovent-certification.com>

Some voluntary data are not certified (i.e. Noise Level for water source units; SCOP for units with Pdesign >70 KW; SCOP MT values).

## TITAN Zero Hi HP SLN

			23.2	27.2	30.2	33.2	38.2	42.2
<b>Cooling</b>								
Refrigeration capacity	(1)	kW	207	230.1	266.6	298.3	316.2	347.5
Total absorbed power	(1)	kW	85.6	96.3	113.6	128.9	145	172.1
EER	(1)		2.42	2.39	2.35	2.31	2.18	2.02
<b>Heating</b>								
Heating capacity	(2)	kW	232.5	254.2	301.9	331.1	355.8	393.7
Total absorbed power	(2)	kW	80.7	86.9	108.3	116.2	128	147
COP	(2)		2.88	2.92	2.79	2.85	2.78	2.68
<b>Compressors</b>								
Compressors/Circuits		n°	2/2					
Minimum capacity reduction step	(7)	%	23					
Refrigerant charge HP	(3)	kg	26.2	28.6	34	37.3	40.1	44.3
<b>Fans</b>								
Quantity		n°	6			8		
Total air flow rate HP		m³/h	117984			157312		
<b>User-side heat exchanger</b>								
Quantity		n°	1					
Water flow rate CH	(1)	m³/h	35.6	39.6	45.9	51.4	54.4	59.8
Pressure drop CH	(1)	kPa	16	20	23	17	19	20
Water flow rate HP	(2)	m³/h	39.9	43.7	51.8	56.9	61.2	67.6
Pressure drop HP	(2)	kPa	22	25	30	23	27	29
<b>Noise levels</b>								
Sound power level cooling	(4)	dB(A)	90		91		92	
Sound pressure level cooling	(6)	dB(A)	57		59		60	
<b>Dimensions and weights**</b>								
Length		mm	5085					
Depth		mm	2250					
Height		mm	2475					
Operating weight		kg	3488	3530	3680	3784	3814	3878

CH: chiller unit; HP: heat pump unit; MCHX: unit with microchannel coils

- (1) External air temperature of 35°C and user-side heat exchanger water inlet-outlet temperature of 12-7°C. Values compliant with standard EN 14511
- (2) Outside air temperature 7°C DB, 6°C WB; condenser inlet/outlet water temperature 40/45°C. Values compliant with standard EN 14511
- (3) Theoretical values referred to the basic unit. The amount of gas actually charged in the unit may differ.
- (4) Unit operating at rated capacity, with no accessories of any kind - external air temperature 35°C and water input/output temperature from/to heat exchanger and user equal to 12/7°C. Values taken by measurements made in accordance with standard ISO 3744 and the Eurovent certification programme, where applicable. Binding values See NOISE LEVELS section.
- (5) unit operating at nominal operating capacity, with no accessories of any kind, with external air temperature of 7°C (6°C WB) and user-side heat exchanger water inlet/outlet temperature of 40/45°C. Values obtained from measurements carried out in accordance with standard ISO 3744.
- (6) Values obtained from the sound power level (conditions: note 4), related to a distance of 10 m from the unit in free field with directivity factor Q=2. Non-binding values See NOISE LEVELS section.
- (7) Approximate value. The minimum capacity reached by the unit depends on the operating conditions. The value shown may not be suitable for calculating the minimum volume of water: to do this, consult the "Minimum water content in the system" section.

\*\* Basic unit without included accessories

The certified standard performances and data can be verified in <https://www.eurovent-certification.com>

Some voluntary data are not certified (i.e. Noise Level for water source units; SCOP for units with Pdesign >70 KW; SCOP MT values).

# ECODESIGN

## INTRODUCTION

The Ecodesign/ErP Directive (2009/125/EC) lays down new standards for more efficient energy use.

The Directive contains various regulations; as regards chiller products and heat pumps, the regulations of interest are the following:

- Regulation 2013/813, for small heat pumps ( $P_{\text{design}} \leq 400$  kW)
- Regulation 2016/2281, for chillers and heat pumps with  $P_{\text{design}} > 400$  kW
- Regulation 2013/811, for heat pumps with  $P_{\text{design}} \leq 70$  kW.

The last-mentioned regulation (2013/811) regards the labelling (Ecolabel certification) of small heat pumps.

The other two regulations (2013/813 and 2016/2281) set seasonal efficiency targets that the products must comply with to be sold and installed in the European Union (essential requirement for CE marking).

These efficiency limits are defined through ratios, which are respectively:

- $\eta_{\text{sh}}$  (SCOP), with reference to regulation 2013/813
- $\eta_{\text{sc}}$  (SEER) for comfort applications and SEPR for process applications, with reference to regulation 2016/2281.

The figure below schematically illustrates the correspondence between product and reference energy ratio.

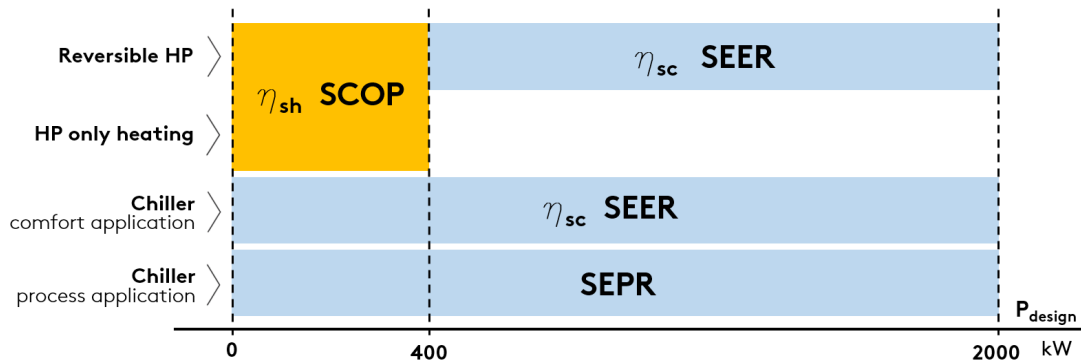

Some notes and clarifications:

For comfort applications, regulation 2016/2281 sets the  $\eta_{\text{sc}}$  (SEER) ratio in two different operating conditions:

- SEER calculated with machine inlet/outlet water temperature of 12/7°C (low temperature application),
- SEER calculated with machine inlet/outlet water temperature of 23/18°C (medium temperature application).

The minimum efficiency requirement is the same, but can be met at condition 12/7°C or at condition 23/18°C, depending on the application envisaged for the machine.

Regulation 2013/813 distinguishes two different types: at low temperature and at medium temperature.

The following refer to the application at low temperature: (low temperature application) all heat pumps whose maximum delivery temperature for heating purposes is lower than 52°C with source at temperature of -7°C and -8°C wet bulb (air-water unit) or inlet 10°C (water-water unit), at the reference design conditions for an average climate. For these, the efficiency ratio is "low temperature application" (outlet water temperature 35°C).

For all the other heat pumps, the efficiency ratio is related to "medium temperature application" (outlet water temperature 55°C).

The ratios must be calculated according to the reference European heating season in average climatic conditions.

The minimum efficiency requirements set by the regulations are indicated below.

REGULATION 2016/2281, comfort application

TYPE OF UNIT		MINIMUM REQUIREMENT	
SOURCE	P <sub>design</sub>	$\eta_{sc}$ [%]	SEER
air	< 400 kW	161	4,1
air	$\geq$ 400 kW	179	4,55
water	< 400 kW	200	5,075
water	$\geq$ 400 kW and < 1500 kW	252	6,375
water	$\geq$ 1500 kW	272	6,875

REGULATION 2016/2281, process application

TYPE OF UNIT		MINIMUM REQUIREMENT
SOURCE	P <sub>design</sub>	SEPR
air	< 400 kW	5
air	$\geq$ 400 kW	5,5
water	< 400 kW	7
water	$\geq$ 400 kW and < 1500 kW	8
water	$\geq$ 1500 kW	8,5

REGULATION 2013/813

SOURCE	APPLICATION	MINIMUM REQUIREMENT	
		$\eta_{sh}$ [%]	SCOP
air	low temperature application	125	3,2
water	low temperature application	125	3,325
air	medium temperature application	110	2,825
water	medium temperature application	110	2,95

The conformity of the product must be checked according to the type of application, whether comfort or process, and at the required outlet water temperature.

The two schematic tables below, respectively for comfort application and for process application, indicate the reference of the required conformity according to the type of product and the set point temperature (reference to regulations 2016/2281 and 2013/813).

Important note: for mixed comfort and process applications, the reference application for conformity is the comfort application.

#### COMFORT APPLICATION

PRODUCT	OUTLET WATER TEMPERATURE	COMPLIANCE INDEX	REGULATION
<b>Chiller</b>	< 18°C	SEER/η <sub>sc</sub> low temperature application	2016/2281
	≥ 18°C	SEER/η <sub>sc</sub> medium temperature application	2016/2281
<b>Heat pumps (reversible and only heating) P<sub>design</sub> ≤ 400kW</b>		SCOP/η <sub>sh</sub>	2013/813
<b>Reversible heat pumps P<sub>design</sub> &gt; 400kW</b>	< 18°C	SEER/η <sub>sc</sub> low temperature application	2016/2281
	≥ 18°C	SEER/η <sub>sc</sub> medium temperature application	2016/2281
<b>Heat pumps only heating P<sub>design</sub> &gt; 400kW</b>		-	-

- = exemption from Ecodesign

#### PROCESS APPLICATION

PRODUCT	OUTLET WATER TEMPERATURE	COMPLIANCE INDEX	REGULATION
<b>Chiller</b>	≥ +2°C , ≤ 12°C	SEPR	2016/2281
	> 12°C	-	-
	> -8°C , < +2°C	-	-

- = exemption from Ecodesign

Some specifications and notes follow.

#### **EC fans:**

The only option that positively affects the performance of the unit, by increasing its seasonal energy efficiency ratio, is the VEC accessory.

A unit equipped with EC fans has a higher SEER (η<sub>sc</sub>) than the configuration with standard fans.

A unit equipped with EC fans has a higher SCOP (η<sub>sh</sub>) than the configuration with standard fans.

## RANGE - TITAN ZERO

As regards, specifically, the TITAN Zero range, here below the regulations of interest for the different units in the different configurations.

- chiller version: regulation 2016/2281
- HP version: regulation 2013/813 (since they are all units with Pdesign ≤ 400 kW).

The tables below give information on the conformity of the units and the seasonal energy performance ratios with regard to the reference regulation.

### TITAN Zero Hi

			23.2	26.3	30.2	33.2	36.2	40.2
<b>REGULATION 2016-2281</b>								
<b>COMFORT</b>								
<b>Standard Unit</b>								
η <sub>sc</sub>	(1)	%	169.04	168.82	162.34	164	162.28	161.52
SEER	(1)		4.3	4.3	4.13	4.18	4.13	4.11
Compliance Tier 2 (2021)	(1)		Y	Y	Y	Y	Y	Y
<b>Unit with EC fans (VEC)</b>								
η <sub>sc</sub>	(1)	%	174.16	173.28	167.24	168.32	166.08	166.34
SEER	(1)		4.43	4.41	4.26	4.28	4.23	4.23
Compliance Tier 2 (2021)	(1)		Y	Y	Y	Y	Y	Y
<b>PROCESS</b>								
SEPR	(2)		-	-	-	-	-	-
Compliance Tier 2 (2021)	(2)		-	-	-	-	-	-

Y = unit in compliance with Ecodesign at the indicated condition. N = unit not in compliance with Ecodesign at the indicated condition: it can be installed only in non-EU countries.

(1) User-side heat exchanger water inlet/outlet temperature 12/7°C (low temperature application), with reference to regulation 2016/2281 and standard EN 14825.

(2) User-side heat exchanger water inlet/outlet temperature 12/7°C, with reference to regulation 2016/2281 and norm EN 14825.

### TITAN Zero Hi SLN

			23.2	26.3	30.2	33.2	36.2	40.2
<b>REGULATION 2016-2281</b>								
<b>COMFORT</b>								
<b>Standard Unit</b>								
η <sub>sc</sub>	(1)	%	167.04	165.86	161.89	162.1	161.5	161.57
SEER	(1)		4.25	4.22	4.12	4.13	4.11	4.11
Compliance Tier 2 (2021)	(1)		Y	Y	Y	Y	Y	Y
<b>Unit with EC fans (VEC)</b>								
η <sub>sc</sub>	(1)	%	172.36	170.56	167	166.63	165.58	165.09
SEER	(1)		4.38	4.34	4.25	4.24	4.21	4.2
Compliance Tier 2 (2021)	(1)		Y	Y	Y	Y	Y	Y
<b>PROCESS</b>								
SEPR	(2)		-	-	-	-	-	-
Compliance Tier 2 (2021)	(2)		-	-	-	-	-	-

Y = unit in compliance with Ecodesign at the indicated condition. N = unit not in compliance with Ecodesign at the indicated condition: it can be installed only in non-EU countries.

(1) User-side heat exchanger water inlet/outlet temperature 12/7°C (low temperature application), with reference to regulation 2016/2281 and standard EN 14825.

(2) User-side heat exchanger water inlet/outlet temperature 12/7°C, with reference to regulation 2016/2281 and norm EN 14825.

The certified standard performances and data can be verified in <https://www.eurovent-certification.com>

Some voluntary data are not certified (i.e. Noise Level for water source units; SCOP for units with Pdesign >70 KW; SCOP MT values).

## TITAN Zero Hi HP

			23.2	27.2	30.2	33.2	38.2	42.2
<b>REGULATION 2013/813</b>			-					
Pdesign	(1)	kW	168	182.4	221.1	238.6	255.4	284.2
<b>COMFORT</b>								
<b>Standard Unit</b>								
ηsh	(1)	%	149	146	144	143	140	131
SCOP LT	(1)		3.79	3.73	3.67	3.65	3.57	3.35
<b>Unit with EC fans (VEC)</b>								
ηsh	(1)	%	156	155	151		150	138
SCOP LT	(1)		3.97	3.94	3.86		3.82	3.52
<b>REGULATION 2013/813</b>			-					
Pdesign	(3)	kW	146.2	158.2	192.8	207.9	224.7	253.3
<b>COMFORT</b>								
<b>Standard Unit</b>								
ηsh	(3)	%	123	122	119		117	110
SCOP MT	(3)		3.15	3.11	3.06	3.04	3	2.83
<b>Unit with EC fans (VEC)</b>								
ηsh	(3)	%	128		125			116
SCOP MT	(3)		3.28	3.27	3.2			2.97

Y = unit in compliance with Ecodesign at the indicated condition. N = unit not in compliance with Ecodesign at the indicated condition: it can be installed only in non-EU countries.

- (1) User-side heat exchanger water inlet/outlet temperature 30/35°C, Average climate profile, with reference to regulation 2013/813 and norm EN 14825.
- (2) Energy efficiency class with reference to regulation 2013/811 (low temperature applications).
- (3) User-side heat exchanger water inlet/outlet temperature 47/55°C, Average climate profile, with reference to regulation 2013/813 and norm EN 14825.

## TITAN Zero Hi HP SLN

			23.2	27.2	30.2	33.2	38.2	42.2
<b>REGULATION 2013/813</b>			-					
Pdesign	(1)	kW	168	182.4	221.1	238.6	255.4	284.2
<b>COMFORT</b>								
<b>Standard Unit</b>								
ηsh	(1)	%	149	146	144	143	140	131
SCOP LT	(1)		3.79	3.73	3.67	3.65	3.57	3.35
<b>Unit with EC fans (VEC)</b>								
ηsh	(1)	%	156	155	151		150	138
SCOP LT	(1)		3.97	3.94	3.86		3.82	3.52
<b>REGULATION 2013/813</b>			-					
Pdesign	(3)	kW	146.2	158.2	192.8	207.9	224.7	253.3
<b>COMFORT</b>								
<b>Standard Unit</b>								
ηsh	(3)	%	123	122	119		117	110
SCOP MT	(3)		3.15	3.11	3.06	3.04	3	2.83
<b>Unit with EC fans (VEC)</b>								
ηsh	(3)	%	128		125			116
SCOP MT	(3)		3.28	3.27	3.2			2.97

Y = unit in compliance with Ecodesign at the indicated condition. N = unit not in compliance with Ecodesign at the indicated condition: it can be installed only in non-EU countries.

- (1) User-side heat exchanger water inlet/outlet temperature 30/35°C, Average climate profile, with reference to regulation 2013/813 and norm EN 14825.
- (2) Energy efficiency class with reference to regulation 2013/811 (low temperature applications).
- (3) User-side heat exchanger water inlet/outlet temperature 47/55°C, Average climate profile, with reference to regulation 2013/813 and norm EN 14825.

The certified standard performances and data can be verified in <https://www.eurovent-certification.com>

Some voluntary data are not certified (i.e. Noise Level for water source units; SCOP for units with Pdesign >70 KW; SCOP MT values).

# ELECTRICAL SPECIFICATIONS

## TITAN Zero Hi

			23.2	26.3	30.2	33.2	36.2	40.2
<b>General electrical specifications</b>								
Max. absorbed current (FLA)	(1)	A	196.4	196.4	239.2	317.2	317.2	365.2
Nominal current (Inom)	(2)	A	141.8	154	203.6	225.2	230.6	247.8
cosφ standard unit	(2)		> 0.95	> 0.95	> 0.95	> 0.95	> 0.95	> 0.95
Power supply		V/ph/Hz	400/3+N/50 Hz					
Power supply for auxiliary circuits		mm <sup>2</sup>	230-24V 50 Hz					
Suggested line section	(5)	mm <sup>2</sup>	3x120+1G70 FG16OR16	3x120+1G70 FG16OR16	3x(2x70)+1G70 FG16OR16	3x(2x95)+1G95 FG16OR16	3x(2x95)+1G95 FG16OR16	3x(2x120)+1G120 FG16OR16
Suggested line protection	(6)		NH1gG 250A	NH1gG 250A	NH2gG 315A	NH2gG 400A	NH2gG 400A	NH3gG 500A
<b>Electrical specifications for fans</b>								
Rated power of standard fan	(1)	n° x kW	6x 1,45	6x 1,45	8x 1,45	8x 1,45	8x 1,45	8x 1,45
Rated current of standard fan	(1)	n° x A	6x 3,4	6x 3,4	8x 3,4	8x 3,4	8x 3,4	8x 3,4
Rated power of EC fan	(2)	n° x kW	6x 1,25	6x 1,25	8x 1,25	8x 1,25	8x 1,25	8x 1,25
Rated current of EC fan	(2)	n° x A	6x 1,9	6x 1,9	8x 1,9	8x 1,9	8x 1,9	8x 1,9
Rated power of oversize EC fan	(2)	n° x kW	6x 2,9	6x 2,9	8x 2,9	8x 2,9	8x 2,9	8x 2,9
Rated current of oversized EC fan	(2)	n° x A	6x 4,4	6x 4,4	8x 4,4	8x 4,4	8x 4,4	8x 4,4

- (1) Data regarding the unit without accessories working in maximum power absorption conditions
- (2) Datum related to the unit without accessories working in standard conditions (A35°C; W12-7°C)
- (3) Maximum effective RMS value of the current when the last compressor starts (FLA of the entire unit - FLA of the largest compressor + LRA of the largest compressor)
- (4) Maximum effective RMS value of the current when the last compressor starts (FLA of the entire unit - FLA of the largest compressor + 0.6 x LRA of the largest compressor)
- (5) These values are determined for cables with operating temperature of 40°C, EPR insulation and a line with a maximum length of 50m. The line section must be determined by a qualified technician based on the protection devices, the length of the line, the type of cable used and the type of installation.
- (6) The correct line protection part must be determined by a qualified technician based on the length of the line, the type of cable used and the type of installation.

## TITAN Zero Hi SLN

			23.2	26.3	30.2	33.2	36.2	40.2
<b>General electrical specifications</b>								
Max. absorbed current (FLA)	(1)	A	196.4	196.4	239.2	317.2	317.2	365.2
Nominal current (Inom)	(2)	A	141.8	154	203.6	225.2	230.6	247.8
cosφ standard unit	(2)		> 0.95	> 0.95	> 0.95	> 0.95	> 0.95	> 0.95
Power supply		V/ph/Hz	400/3+N/50 Hz					
Power supply for auxiliary circuits		mm <sup>2</sup>	230-24V 50 Hz					
Suggested line section	(5)	mm <sup>2</sup>	3x120+1G70 FG16OR16	3x120+1G70 FG16OR16	3x(2x70)+1G70 FG16OR16	3x(2x95)+1G95 FG16OR16	3x(2x95)+1G95 FG16OR16	3x(2x120)+1G120 FG16OR16
Suggested line protection	(6)		NH1gG 250A	NH1gG 250A	NH2gG 315A	NH2gG 400A	NH2gG 400A	NH3gG 500A
<b>Electrical specifications for fans</b>								
Rated power of standard fan	(1)	n° x kW	6x 1,45	6x 1,45	8x 1,45	8x 1,45	8x 1,45	8x 1,45
Rated current of standard fan	(1)	n° x A	6x 3,4	6x 3,4	8x 3,4	8x 3,4	8x 3,4	8x 3,4
Rated power of EC fan	(2)	n° x kW	6x 1,25	6x 1,25	8x 1,25	8x 1,25	8x 1,25	8x 1,25
Rated current of EC fan	(2)	n° x A	6x 1,9	6x 1,9	8x 1,9	8x 1,9	8x 1,9	8x 1,9
Rated power of oversize EC fan	(2)	n° x kW	6x 2,9	6x 2,9	8x 2,9	8x 2,9	8x 2,9	8x 2,9
Rated current of oversized EC fan	(2)	n° x A	6x 4,4	6x 4,4	8x 4,4	8x 4,4	8x 4,4	8x 4,4

- (1) Data regarding the unit without accessories working in maximum power absorption conditions
- (2) Datum related to the unit without accessories working in standard conditions (A35°C; W12-7°C)
- (3) Maximum effective RMS value of the current when the last compressor starts (FLA of the entire unit - FLA of the largest compressor + LRA of the largest compressor)
- (4) Maximum effective RMS value of the current when the last compressor starts (FLA of the entire unit - FLA of the largest compressor + 0.6 x LRA of the largest compressor)
- (5) These values are determined for cables with operating temperature of 40°C, EPR insulation and a line with a maximum length of 50m. The line section must be determined by a qualified technician based on the protection devices, the length of the line, the type of cable used and the type of installation.
- (6) The correct line protection part must be determined by a qualified technician based on the length of the line, the type of cable used and the type of installation.

## TITAN Zero Hi HP

			23.2	27.2	30.2	33.2	38.2	42.2
<b>General electrical specifications</b>								
Max. absorbed current (FLA)	(1)	A	196.4	196.4	239.2	317.2	317.2	365.2
Nominal current (Inom)	(2)	A	141.8	154	203.6	225.2	230.6	247.8
cosφ standard unit	(2)		> 0.95	> 0.95	> 0.95	> 0.95	> 0.95	> 0.95
Power supply		V/ph/Hz	400/3+N/50 Hz					
Power supply for auxiliary circuits		mm <sup>2</sup>	230-24V 50 Hz					
Suggested line section	(5)	mm <sup>2</sup>	3x120+1G70 FG16OR16	3x120+1G70 FG16OR16	3x(2x70)+1G70 FG16OR16	3x(2x95)+1G95 FG16OR16	3x(2x95)+1G95 FG16OR16	3x(2x120)+1G120 FG16OR16
Suggested line protection	(6)		NH1gG 250A	NH1gG 250A	NH2gG 315A	NH2gG 400A	NH2gG 400A	NH3gG 500A
<b>Electrical specifications for fans</b>								
Rated power of standard fan	(1)	n° x kW	6x 1,45	6x 1,45	8x 1,45	8x 1,45	8x 1,45	8x 1,45
Rated current of standard fan	(1)	n° x A	6x 3,4	6x 3,4	8x 3,4	8x 3,4	8x 3,4	8x 3,4
Rated power of EC fan	(2)	n° x kW	6x 1,25	6x 1,25	8x 1,25	8x 1,25	8x 1,25	8x 1,25
Rated current of EC fan	(2)	n° x A	6x 1,9	6x 1,9	8x 1,9	8x 1,9	8x 1,9	8x 1,9
Rated power of oversize EC fan	(2)	n° x kW	6x 2,9	6x 2,9	8x 2,9	8x 2,9	8x 2,9	8x 2,9
Rated current of oversized EC fan	(2)	n° x A	6x 4,4	6x 4,4	8x 4,4	8x 4,4	8x 4,4	8x 4,4

- (1) Data regarding the unit without accessories working in maximum power absorption conditions
- (2) Datum related to the unit without accessories working in standard conditions (A35°C; W12-7°C)
- (3) Maximum effective RMS value of the current when the last compressor starts (FLA of the entire unit - FLA of the largest compressor + LRA of the largest compressor)
- (4) Maximum effective RMS value of the current when the last compressor starts (FLA of the entire unit - FLA of the largest compressor + 0.6 x LRA of the largest compressor)
- (5) These values are determined for cables with operating temperature of 40°C, EPR insulation and a line with a maximum length of 50m. The line section must be determined by a qualified technician based on the protection devices, the length of the line, the type of cable used and the type of installation.
- (6) The correct line protection part must be determined by a qualified technician based on the length of the line, the type of cable used and the type of installation.

## TITANZero Hi HP SLN

			23.2	27.2	30.2	33.2	38.2	42.2
<b>General electrical specifications</b>								
Max. absorbed current (FLA)	(1)	A	196.4	196.4	239.2	317.2	317.2	365.2
Nominal current (Inom)	(2)	A	141.8	154	203.6	225.2	230.6	247.8
cosφ standard unit	(2)		> 0.95	> 0.95	> 0.95	> 0.95	> 0.95	> 0.95
Power supply		V/ph/Hz	400/3+N/50 Hz					
Power supply for auxiliary circuits		mm <sup>2</sup>	230-24V 50 Hz					
Suggested line section	(5)	mm <sup>2</sup>	3x120+1G70 FG16OR16	3x120+1G70 FG16OR16	3x(2x70)+1G70 FG16OR16	3x(2x95)+1G95 FG16OR16	3x(2x95)+1G95 FG16OR16	3x(2x120)+1G120 FG16OR16
Suggested line protection	(6)		NH1gG 250A	NH1gG 250A	NH2gG 315A	NH2gG 400A	NH2gG 400A	NH3gG 500A
<b>Electrical specifications for fans</b>								
Rated power of standard fan	(1)	n° x kW	6x 1,45	6x 1,45	8x 1,45	8x 1,45	8x 1,45	8x 1,45
Rated current of standard fan	(1)	n° x A	6x 3,4	6x 3,4	8x 3,4	8x 3,4	8x 3,4	8x 3,4
Rated power of EC fan	(2)	n° x kW	6x 1,25	6x 1,25	8x 1,25	8x 1,25	8x 1,25	8x 1,25
Rated current of EC fan	(2)	n° x A	6x 1,9	6x 1,9	8x 1,9	8x 1,9	8x 1,9	8x 1,9
Rated power of oversize EC fan	(2)	n° x kW	6x 2,9	6x 2,9	8x 2,9	8x 2,9	8x 2,9	8x 2,9
Rated current of oversized EC fan	(2)	n° x A	6x 4,4	6x 4,4	8x 4,4	8x 4,4	8x 4,4	8x 4,4

- (1) Data regarding the unit without accessories working in maximum power absorption conditions
- (2) Datum related to the unit without accessories working in standard conditions (A35°C; W12-7°C)
- (3) Maximum effective RMS value of the current when the last compressor starts (FLA of the entire unit - FLA of the largest compressor + LRA of the largest compressor)
- (4) Maximum effective RMS value of the current when the last compressor starts (FLA of the entire unit - FLA of the largest compressor + 0.6 x LRA of the largest compressor)
- (5) These values are determined for cables with operating temperature of 40°C, EPR insulation and a line with a maximum length of 50m. The line section must be determined by a qualified technician based on the protection devices, the length of the line, the type of cable used and the type of installation.
- (6) The correct line protection part must be determined by a qualified technician based on the length of the line, the type of cable used and the type of installation.

# HYDRAULIC MODULES

## TITAN Zero Hi - TITAN Zero Hi SLN

			23.2	26.3	30.2	33.2	36.2	40.2
Volume of the expansion vessel		I	18	18	18	18	18	18
Volume of the buffer tank CH		I	500	500	500	500	500	500
<b>Small pumps</b>								
Pump model 1Pr, 2Pr			P15 / P17	P1 / P10	P1 / P10	P1 / P10	P1 / P10	P7 / P8
Available head 1Pr	(1)	kPa	145	186	174	161	151	152
Available head 2Pr	(1)	kPa	148	187	174	161	151	143
<b>Standard pumps</b>								
Pump model 1S, 2S			P1 / P10	P2 / P11	P2 / P11	P2 / P11	P2 / P11	P3 / P11
Available head 1P	(1)	kPa	192	251	241	230	221	192
Available head 2P	(1)	kPa	194	246	234	223	213	198
<b>Pumps for glycol</b>								
Pump model 1PG, 2PG			P6 / P14	P6 / P14	P6 / P14	P6 / P14	P16 / P18	P16 / P18
Available head 1PG	(1)	kPa	284	278	266	253	324	306
Available head 2PG	(1)	kPa	307	299	285	270	298	279

(1) External air temperature 35°C, user-side heat exchanger water inlet/outlet temperature 12/7°C. Values in accordance with EN 14511.

## TITAN Zero Hi HP - TITAN Zero Hi HP SLN

			23.2	27.2	30.2	33.2	38.2	42.2
Volume of the expansion vessel		I	18	18	18	18	18	18
Volume of the buffer tank HP		I	500	500	500	500	500	500
<b>Small pumps</b>								
Pump model 1Pr, 2Pr			P1, P10	P1, P10	P7, P8	P7, P8	P3, , P12	P3, , P12
Available head 1Pr	(1)	kPa	145	133	113	114	136	124
Available head 2Pr	(1)	kPa	142	129	98	100	120	106
<b>Standard pumps</b>								
Pump model 1S, 2S			P2, P11	P2, P11	P3, P11	P3, P11	P4, P13	P4, P13
Available head 1P	(1)	kPa	210	199	154	154	194	182
Available head 2P	(1)	kPa	200	188	169	162	178	166
<b>Pumps for glycol</b>								
Pump model 1PG, 2PG			P6, P14	P6, P14	P5, P9	P5, P9	P5, P9	P5, P9
Available head 1PG	(1)	kPa	212	197	227	232	217	201
Available head 2PG	(1)	kPa	227	211	225	230	216	201

(1) External air temperature 35°C, user-side heat exchanger water inlet/outlet temperature 12/7°C. Values in accordance with EN 14511.

## PUMP DATA

Model	Rated power	Rated current	Min. flow rate	Max. flow rate
	kW	A	m <sup>3</sup> /h	m <sup>3</sup> /h
<b>P1</b>	3	6,3	15,1	53,1
<b>P2</b>	4	7,6	13,9	57
<b>P3</b>	2,2	4,5	12	44
<b>P4</b>	3	6,3	17	47
<b>P5</b>	4	7,6	27	63,6
<b>P6</b>	5,5	10,5	27	82,3
<b>P7</b>	5,5	10,5	36	108,5
<b>P8</b>	7,5	14,1	36	138,5
<b>P9</b>	11	20,2	36	157,2
<b>P10</b>	11	20,2	68	213,4
<b>P11</b>	15	26,6	68	247,1
<b>P12</b>	18,5	33	68	271,4
<b>P13</b>	7,5	14,1	27	101
<b>P14</b>	7,5	14,1	20,5	97
<b>P15</b>	9,2	20,2	23,8	108
<b>P16</b>	4	7,6	24	90
<b>P17</b>	4	7,3	22,8	90
<b>P18</b>	11	20,2	36	134,7

## USER-SIDE EXCHANGER FLOW RATE FIELDS

### Chiller

The units are sized and optimized for the following nominal conditions: external air 35°C, inlet/outlet of the user-side heat exchanger 12/7°C

### Heat pump

The units are sized and optimized for the following nominal conditions: outside air temperature 7°C, user side heat exchanger inlet/outlet water temperature 40/45°C;

The units can work at design conditions different from nominal conditions, provided that:

- the design condition falls within the operating limits specified below
- the unit is equipped with all the accessories necessary for operation (e.g. brine kit, fan speed adjuster)
- the flow rate at design conditions (that is, of the specific application) must always come within the allowed flow rate ranges specified below. If the design conditions require a water flow rate that does not come within the allowed operating range, you must contact our sales department that will identify the most suitable solution for the specific application.

### TITAN Zero Hi / TITAN Zero Hi SLN

	Qmin	Qmax
	m <sup>3</sup> /h	m <sup>3</sup> /h
<b>23.2</b>	19,7	59
<b>26.3</b>	22,1	66,4
<b>30.2</b>	25,2	75,7
<b>33.2</b>	28,6	85,7
<b>36.2</b>	30,7	92,1
<b>40.2</b>	34,3	102,9

### TITAN Zero Hi HP / TITAN Zero Hi HP SLN

	Qmin	Qmax
	m <sup>3</sup> /h	m <sup>3</sup> /h
<b>23.2</b>	20,0	59,9
<b>27.2</b>	21,9	65,6
<b>30.2</b>	25,9	77,8
<b>33.2</b>	28,5	85,4
<b>38.2</b>	30,6	91,9
<b>42.2</b>	33,8	101,5

# OPERATING LIMITS

## TITAN ZERO HI - TITAN ZERO HI SLN

### COOLING

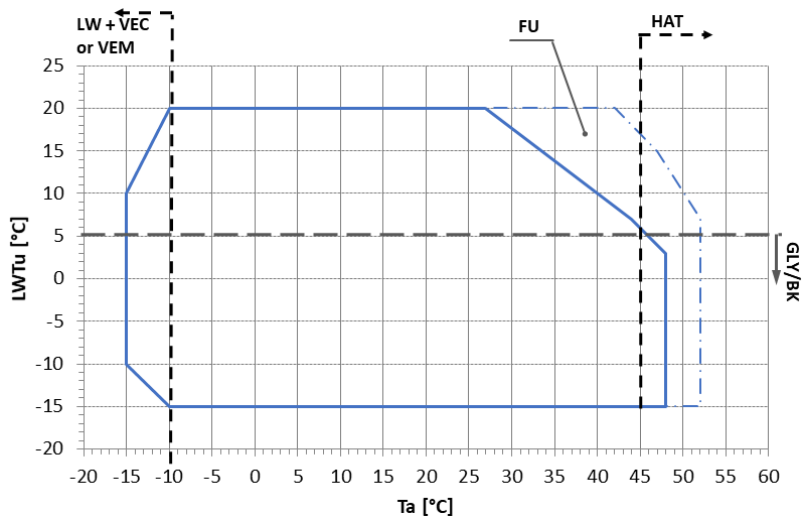

### TOTAL RECOVERY

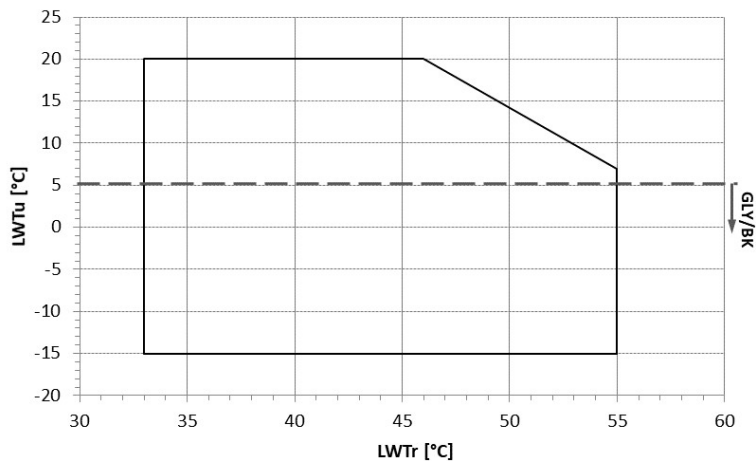

**Ta:** external air temperature

**LWTu:** water outlet temperature from the user-side heat exchanger

**LWTr:** water outlet temperature from the recovery exchanger

**LW:** in the indicated area, the unit can work only where there is no wind

**/VEC or /VEM:** in the indicated area, the unit can work only if fitted with the accessory /VEC or /VEM

**FU:** in the area indicated, the control could implement a forced partialization of the compressors in order to avoid the intervention of the safety devices.

**/HAT:** in the indicated area, the unit can work only if fitted with the accessory /HAT

**GLY:** For LWTu below +5°C, it is compulsory to use suitable percentages of antifreeze additives (glycols) to prevent ice formation in the exchanger.

**/BK:** in the indicated area, the unit can work only if fitted with the accessory /BK

The inlet and outlet temperatures of the user-side exchanger must be given on ordering to allow correct setting of the alarm parameters and verification of the sizing of the expansion valve.

The cooling set point can then be changed by the customer in an interval that, compared to the set point given on ordering, ranges from -1K up to the maximum temperature allowed by the above-stated operating limits.

The unit will be optimized to work at the set point temperatures given on ordering. For different set points, the cooling capacity provided and the level of efficiency of the machine could decrease and move away from these conditions.

# TITAN ZERO HI HP - TITAN ZERO HI HP SLN

## COOLING

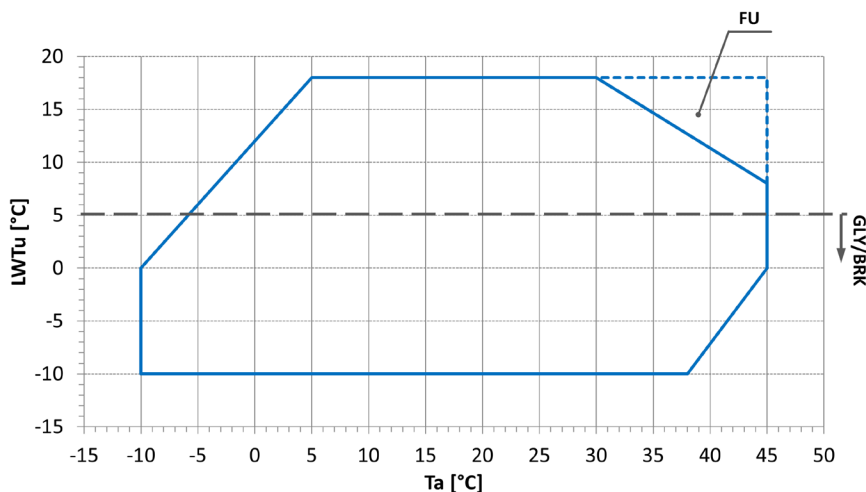

## HEATING

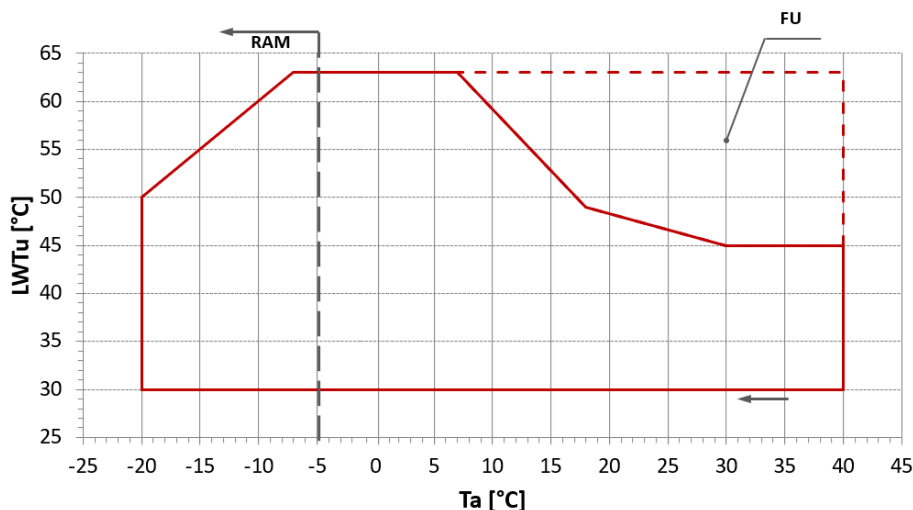

**Ta:** external air temperature

**LWTu:** water outlet temperature from the user-side heat exchanger

**LWTr:** water outlet temperature from the recovery exchanger

**FU:** in the area indicated, the control could implement a forced partialization of the compressors in order to avoid the intervention of the safety devices.

**GLY:** For LWTu below +5°C, it is compulsory to use suitable percentages of antifreeze additives (glycols) to prevent ice formation in the exchanger.

**/BK:** in the indicated area, the unit can work only if fitted with the accessory /BK

**/RAM:** in the indicated area, the unit can work only if fitted with the accessory /RAM. Recommended accessory for installations in regions with temperatures below -5°C or in the case of installations particularly exposed to cold winds.

The inlet and outlet temperatures of the user-side exchanger must be given on ordering to allow correct setting of the alarm parameters and verification of the sizing of the expansion valve.

The cooling set point can then be changed by the customer in an interval that, compared to the set point given on ordering, ranges from -1K up to the maximum temperature allowed by the above-stated operating limits.

The unit will be optimized to work at the set point temperatures given on ordering. For different set points, the cooling capacity provided and the level of efficiency of the machine could decrease and move away from these conditions.

## TITAN Zero Hi Octave bands [dB]

	63 Hz		125 Hz		250 Hz		500 Hz	
	Lw	Lp	Lw	Lp	Lw	Lp	Lw	Lp
<b>23.2</b>	102.2	69.8	102.9	70.5	90.5	58.1	87.3	54.9
<b>26.3</b>	102.2	69.8	102.9	70.5	90.5	58.1	87.3	54.9
<b>30.2</b>	103.5	71.1	104.7	72.3	92	59.5	88.7	56.3
<b>33.2</b>	103.5	71.1	104.9	72.5	92.1	59.7	88.9	56.5
<b>36.2</b>	103.5	71.1	105.3	72.8	92.3	59.8	89	56.6
<b>40.2</b>	103.6	71.2	106	73.6	92.6	60.2	89.4	57

## TITAN Zero Hi Octave bands [dB]

	1000 Hz		2000 Hz		4000 Hz		8000 Hz		Total	
	Lw	Lp	Lw	Lp	Lw	Lp	Lw	Lp	Lw	Lp
<b>23.2</b>	85.1	52.7	79.9	47.5	76.7	44.3	67.8	35.4	<b>92</b>	<b>59</b>
<b>26.3</b>	85.1	52.7	79.9	47.5	76.7	44.3	67.8	35.4	<b>92</b>	<b>59</b>
<b>30.2</b>	86.5	54.1	81.1	48.7	77.9	45.5	69.1	36.7	<b>93</b>	<b>61</b>
<b>33.2</b>	86.5	54.1	81.1	48.7	77.9	45.5	69.1	36.7	<b>93</b>	<b>61</b>
<b>36.2</b>	86.6	54.2	81.2	48.8	77.9	45.5	69.1	36.7	<b>93</b>	<b>61</b>
<b>40.2</b>	86.7	54.3	81.2	48.8	77.9	45.5	69.2	36.8	<b>94</b>	<b>62</b>

Reference conditions: outside air temperature 35°C; input/output water temperature into/from user-side heat exchanger 12/7°C; unit operating at rated capacity, without any option.

**Lw:** sound power levels. Values obtained from measures taken according to standard ISO 3744. Lw\_tot is the only binding value.

**Lp:** sound pressure levels. Binding values starting from noise power levels referred to a distance of 10 m from the unit; source installed on a reflective surface and in ideal free field conditions with directivity factor Q=2. Non-binding values

The acoustic data are related to standard conditions in referable and reproducible operating conditions. All data with the exception of Lw\_tot are provided for illustrative purposes only and can not be used for forecasting purposes or for the verification of binding limits. With special reference to noise emissions, the Manufacturer takes liability for their conformity, limited to the declared Lw\_tot value. Any and all other Manufacturer's liability for the impact of such emissions in relation to the location of the machine and other conditions related to machine installation is excluded. The environment and the installation conditions, as well as the operating modes, can alter the sound emissions. Any assessment concerning these conditions falls within the area of competence of the plant designer and/or the fitter.

The certified standard performances and data can be verified in <https://www.eurovent-certification.com>

Some voluntary data are not certified (i.e. Noise Level for water source units; SCOP for units with Pdesign >70 KW; SCOP MT values).

## TITAN Zero Hi SLN

### Octave bands [dB]

	63 Hz		125 Hz		250 Hz		500 Hz	
	Lw	Lp	Lw	Lp	Lw	Lp	Lw	Lp
<b>23.2</b>	100.2	67.8	100.9	68.5	88.5	56.1	85.3	52.9
<b>26.3</b>	100.2	67.8	100.9	68.5	88.5	56.1	85.3	52.9
<b>30.2</b>	101.5	69.1	102.7	70.3	90	57.5	86.7	54.3
<b>33.2</b>	101.5	69.1	102.9	70.5	90.1	57.7	86.9	54.5
<b>36.2</b>	101.5	69.1	103.3	70.8	90.3	57.8	87	54.6
<b>40.2</b>	101.6	69.2	104	71.6	90.6	58.2	87.4	55

## TITAN Zero Hi SLN

### Octave bands [dB]

	1000 Hz		2000 Hz		4000 Hz		8000 Hz		Total	
	Lw	Lp	Lw	Lp	Lw	Lp	Lw	Lp	Lw	Lp
<b>23.2</b>	83.1	50.7	77.9	45.5	74.7	42.3	65.8	33.4	<b>90</b>	<b>57</b>
<b>26.3</b>	83.1	50.7	77.9	45.5	74.7	42.3	65.8	33.4	<b>90</b>	<b>57</b>
<b>30.2</b>	84.5	52.1	79.1	46.7	75.9	43.5	67.1	34.7	<b>91</b>	<b>59</b>
<b>33.2</b>	84.5	52.1	79.1	46.7	75.9	43.5	67.1	34.7	<b>91</b>	<b>59</b>
<b>36.2</b>	84.6	52.2	79.2	46.8	75.9	43.5	67.1	34.7	<b>91</b>	<b>59</b>
<b>40.2</b>	84.7	52.3	79.2	46.8	75.9	43.5	67.2	34.8	<b>92</b>	<b>60</b>

Reference conditions: outside air temperature 35°C; input/output water temperature into/from user-side heat exchanger 12/7°C; unit operating at rated capacity, without any option.

**Lw:** sound power levels. Values obtained from measures taken according to standard ISO 3744. Lw\_tot is the only binding value.

**Lp:** sound pressure levels. Binding values starting from noise power levels referred to a distance of 10 m from the unit; source installed on a reflective surface and in ideal free field conditions with directivity factor Q=2. Non-binding values

The acoustic data are related to standard conditions in referable and reproducible operating conditions. All data with the exception of Lw\_tot are provided for illustrative purposes only and can not be used for forecasting purposes or for the verification of binding limits. With special reference to noise emissions, the Manufacturer takes liability for their conformity, limited to the declared Lw\_tot value. Any and all other Manufacturer's liability for the impact of such emissions in relation to the location of the machine and other conditions related to machine installation is excluded. The environment and the installation conditions, as well as the operating modes, can alter the sound emissions. Any assessment concerning these conditions falls within the area of competence of the plant designer and/or the fitter.

The certified standard performances and data can be verified in <https://www.eurovent-certification.com>

Some voluntary data are not certified (i.e. Noise Level for water source units; SCOP for units with Pdesign >70 KW; SCOP MT values).

## TITAN Zero Hi HP

### Octave bands [dB]

	63 Hz		125 Hz		250 Hz		500 Hz		1000 Hz	
	Lw	Lp	Lw	Lp	Lw	Lp	Lw	Lp	Lw	Lp
<b>23.2</b>	102.2	69.8	103	70.6	90.6	58.2	87.3	54.9	85.2	52.8
<b>27.2</b>	102.2	69.8	103	70.6	90.6	58.2	87.3	54.9	85.2	52.8
<b>30.2</b>	103.5	71.1	104.7	72.3	92	59.6	88.8	56.4	86.5	54.1
<b>33.2</b>	103.5	71.1	105	72.6	92.1	59.7	88.9	56.5	86.6	54.2
<b>38.2</b>	103.6	71.2	105.3	72.9	92.3	59.9	89.1	56.7	86.6	54.2
<b>42.2</b>	103.7	71.3	106.1	73.6	92.6	60.2	89.4	57	86.8	54.4

## TITAN Zero Hi HP

### Octave bands [dB]

	2000 Hz		4000 Hz		8000 Hz		Total	
	Lw	Lp	Lw	Lp	Lw	Lp	Lw	Lp
<b>23.2</b>	79.9	47.5	76.7	44.3	67.9	35.5	<b>92</b>	<b>59</b>
<b>27.2</b>	79.9	47.5	76.7	44.3	67.9	35.5	<b>92</b>	<b>59</b>
<b>30.2</b>	81.2	48.8	78	45.6	69.1	36.7	<b>93</b>	<b>61</b>
<b>33.2</b>	81.2	48.8	78	45.6	69.2	36.7	<b>93</b>	<b>61</b>
<b>38.2</b>	81.2	48.8	78	45.6	69.2	36.8	<b>94</b>	<b>61</b>
<b>42.2</b>	81.3	48.8	78	45.6	69.2	36.8	<b>94</b>	<b>62</b>

Reference conditions: outside air temperature 35°C; input/output water temperature into/from user-side heat exchanger 12/7°C; unit operating at rated capacity, without any option.

**Lw:** sound power levels. Values obtained from measures taken according to standard ISO 3744. Lw\_tot is the only binding value.

**Lp:** sound pressure levels. Binding values starting from noise power levels referred to a distance of 10 m from the unit; source installed on a reflective surface and in ideal free field conditions with directivity factor Q=2. Non-binding values

The acoustic data are related to standard conditions in referable and reproducible operating conditions. All data with the exception of Lw\_tot are provided for illustrative purposes only and can not be used for forecasting purposes or for the verification of binding limits. With special reference to noise emissions, the Manufacturer takes liability for their conformity, limited to the declared Lw\_tot value. Any and all other Manufacturer's liability for the impact of such emissions in relation to the location of the machine and other conditions related to machine installation is excluded. The environment and the installation conditions, as well as the operating modes, can alter the sound emissions. Any assessment concerning these conditions falls within the area of competence of the plant designer and/or the fitter.

The certified standard performances and data can be verified in <https://www.eurovent-certification.com>

Some voluntary data are not certified (i.e. Noise Level for water source units; SCOP for units with Pdesign >70 KW; SCOP MT values).

## TITAN Zero Hi HP SLN

### Octave bands [dB]

	63 Hz		125 Hz		250 Hz		500 Hz	
	Lw	Lp	Lw	Lp	Lw	Lp	Lw	Lp
<b>23.2</b>	100.2	67.8	101	68.6	88.6	56.2	85.3	52.9
<b>27.2</b>	100.2	67.8	101	68.6	88.6	56.2	85.3	52.9
<b>30.2</b>	101.5	69.1	102.7	70.3	90	57.6	86.8	54.4
<b>33.2</b>	101.5	69.1	103	70.6	90.1	57.7	86.9	54.5
<b>38.2</b>	101.6	69.2	103.3	70.9	90.3	57.9	87.1	54.7
<b>42.2</b>	101.7	69.3	104.1	71.6	90.6	58.2	87.4	55

## TITAN Zero Hi HP SLN

### Octave bands [dB]

	1000 Hz		2000 Hz		4000 Hz		8000 Hz		Total	
	Lw	Lp	Lw	Lp	Lw	Lp	Lw	Lp	Lw	Lp
<b>23.2</b>	83.2	50.8	77.9	45.5	74.7	42.3	65.9	33.5	<b>90</b>	<b>57</b>
<b>27.2</b>	83.2	50.8	77.9	45.5	74.7	42.3	65.9	33.5	<b>90</b>	<b>57</b>
<b>30.2</b>	84.5	52.1	79.2	46.8	76	43.6	67.1	34.7	<b>91</b>	<b>59</b>
<b>33.2</b>	84.6	52.2	79.2	46.8	76	43.6	67.2	34.7	<b>91</b>	<b>59</b>
<b>38.2</b>	84.6	52.2	79.2	46.8	76	43.6	67.2	34.8	<b>92</b>	<b>59</b>
<b>42.2</b>	84.8	52.4	79.3	46.8	76	43.6	67.2	34.8	<b>92</b>	<b>60</b>

Reference conditions: outside air temperature 35°C; input/output water temperature into/from user-side heat exchanger 12/7°C; unit operating at rated capacity, without any option.

**Lw:** sound power levels. Values obtained from measures taken according to standard ISO 3744. Lw\_tot is the only binding value.

**Lp:** sound pressure levels. Binding values starting from noise power levels referred to a distance of 10 m from the unit; source installed on a reflective surface and in ideal free field conditions with directivity factor Q=2. Non-binding values

The acoustic data are related to standard conditions in referable and reproducible operating conditions. All data with the exception of Lw\_tot are provided for illustrative purposes only and can not be used for forecasting purposes or for the verification of binding limits. With special reference to noise emissions, the Manufacturer takes liability for their conformity, limited to the declared Lw\_tot value. Any and all other Manufacturer's liability for the impact of such emissions in relation to the location of the machine and other conditions related to machine installation is excluded. The environment and the installation conditions, as well as the operating modes, can alter the sound emissions. Any assessment concerning these conditions falls within the area of competence of the plant designer and/or the fitter.

The certified standard performances and data can be verified in <https://www.eurovent-certification.com>

Some voluntary data are not certified (i.e. Noise Level for water source units; SCOP for units with Pdesign >70 KW; SCOP MT values).

## CONFIGURATIONS THAT ARE NOT POSSIBLE

### TITAN Zero Hi / TITAN Zero Hi SLN

	CHILLER							
	*Px	*PxS	DS	DS & *Px	DS & *PxS	DC	DC & *PxS	DC & *PxS
<b>23.2</b>								n.a
<b>26.2</b>								n.a
<b>30.2</b>								n.a
<b>33.2</b>								n.a
<b>36.2</b>								n.a
<b>40.2</b>								n.a

n.a.: configuration not available

(1): The unit is realized on a structure bigger than standard

(RFQ): Please contact our sales department to verify its compatibility with the specific configuration and require a quotation

\*: 1 o 2 pumps

Px: P / Pr / PM / PG (& S = tank, if explicitly indicated)

### TITAN Zero Hi HP - TITAN Zero Hi HP SLN

	HEAT PUMP				
	*Px	*PxS	DS	DS & *Px	DS & *PxS
<b>23.2</b>					
<b>27.2</b>					
<b>30.2</b>					
<b>33.2</b>					
<b>38.2</b>					
<b>42.2</b>					

n.a.: configuration not available

(1): The unit is realized on a structure bigger than standard

(RFQ): Please contact our sales department to verify its compatibility with the specific configuration and require a quotation

\*: 1 o 2 pumps

Px: P / Pr / PM / PG (& S = tank, if explicitly indicated)

## INSTALLATION ADVICE

The units described in this document are, by nature, strongly affected by the characteristics of the system, the working conditions and the installation site.

Remember that the unit must be installed by a qualified and skilled technician, and in compliance with the national legislation in force in the destination country.

The installation must be done in such a way that it will be possible to carry out all routine and non-routine maintenance operations.

Before starting any work, you must carefully read the "Installation, operation and maintenance manual" of the machine and do the necessary safety checks to prevent any malfunctioning or hazards.

We give some advice below that will allow you to increase the efficiency and reliability of the unit and therefore of the system into which it is inserted.

### Water characteristics

To preserve the life of the exchangers, the water is required to comply with some quality parameters and it is therefore necessary to make sure its values fall within the ranges indicated in the following table:

<b>Total hardness</b>	2,0 ÷ 6,0 °f 1,2 ÷ 3,4 °d
<b>Langelier index</b>	- 0,4 ÷ 0,4
<b>pH</b>	7,5 ÷ 8,5
<b>Electrical conductivity</b>	10÷500 µS/cm
<b>Organic elements</b>	-
<b>Hydrogen carbonate (HCO<sub>3</sub><sup>-</sup>)</b>	70 ÷ 300 ppm
<b>Sulphates (SO<sub>4</sub><sup>2-</sup>)</b>	< 50 ppm
<b>Hydrogen carbonate / Sulphates (HCO<sub>3</sub><sup>-</sup>/SO<sub>4</sub><sup>2-</sup>)</b>	> 1
<b>Chlorides (Cl<sup>-</sup>)</b>	< 50 ppm
<b>Nitrates (NO<sub>3</sub><sup>-</sup>)</b>	< 50 ppm
<b>Hydrogen sulphide (H<sub>2</sub>S)</b>	< 0,05 ppm
<b>Ammonia (NH<sub>3</sub>)</b>	< 0,05 ppm
<b>Sulphites (SO<sub>3</sub><sup>-</sup>), free chlorine (Cl<sub>2</sub>)</b>	< 1 ppm
<b>Carbon dioxide (CO<sub>2</sub>)</b>	< 5 ppm
<b>Metal cations</b>	< 0,2 ppm
<b>Manganese ions (Mn<sup>++</sup>)</b>	< 0,2 ppm
<b>Iron ions ( Fe<sup>2+</sup> , Fe<sup>3+</sup>)</b>	< 0,2 ppm
<b>Iron + Manganese</b>	< 0,4 ppm
<b>Phosphates (PO<sub>4</sub><sup>3-</sup>)</b>	< 2 ppm
<b>Oxygen</b>	< 0,1 ppm

Installation of water filters on all the hydraulic circuits is obligatory.

The supply of the most suitable filters for the unit can be requested as accessory. In this case, the filters are supplied loose and must be installed by the customer following the instructions given in the installation, operation and maintenance manual.

### Glycol mixtures

With temperatures below 5°C, it is mandatory to work with water and anti-freeze mixtures, and also change the safety devices (anti-freeze, etc.), which must be carried out by qualified authorised personnel or by the manufacturer.

<b>Liquid outlet temperature or minimum ambient temperature</b>	°C	0	-5	-10	-15	-20	-25	-30	-35	-40
<b>Freezing point</b>	°C	-5	-10	-15	-20	-25	-30	-35	-40	-45
<b>Ethylene glycol</b>	%	6	22	30	36	41	46	50	53	56
<b>Propylene glycol</b>	%	15	25	33	39	44	48	51	54	57

The quantity of antifreeze should be considered as % on weight

---

## Minimum water content in the system

For correct operation of the unit, it is necessary to ensure a buffering on the system such as to comply with the minimum operating time considering the greater between the minimum OFF time and the minimum ON time. In short, these contribute to limiting the number of times the compressors are switched on per hour and to preventing undesired deviations from the set point of the delivered water temperature.

Larger amounts of water are in any case always preferable, because they allow a smaller number of starts and switch-offs of the compressors, less wear of them and an increase in the efficiency of the system as a consequence of a reduction in the number of transients.

It should also be pointed out that, for air-water units working in heat pump mode, the minimum amount of water must consider the need of the unit to carry out defrosting. Having an adequate buffering volume will allow prevention of too high drifts of the delivered water temperature at the end of the defrost cycle.

The following experimental formula allows to calculate the minimum water volume of the plant. Formula refers to unit operation in cooling mode and is also valid for heating mode if defrosting cycles are not taken in account.

$$V_{min} = \frac{P_{tot} \cdot 1000}{N} \cdot \frac{300}{\Delta T \rho C_p} + P_{tot} \cdot 0.25$$

$$V_{min} = \frac{P_{tot}}{N} \cdot 28.66 + P_{tot} \cdot 0.25$$

where

$V_{min}$  is the minimum water content of the system [l]

$P_{tot}$  is the total cooling capacity of the machine [kW]

N: number of capacity reduction steps

$\Delta T$ : differential allowed on the water temperature. Unless otherwise specified, this value is considered to be 2.5K

$\rho$ : density of the heat-carrying fluid. Unless otherwise specified, the density of water is considered

$c_p$ : specific heat of the heat-carrying fluid. Unless otherwise specified, the specific heat of water is considered

Considering the use of water and grouping together some terms, the formula can be re-written as follows:

For the N values, consider the following convention:

- for units with 2 compressor N = 4

In case of installation in cold climates where the unit has to perform defrosting cycles, it is suggested to use higher water content than that calculated with previous formula; due to very high volumes needed to completely compensate the negative effect of defrost on produced water temperature, are usually accepted higher temperature deviations than typical values accepted for cooling-only unit.

Water content necessary to balance defrost cycle effect on produced water temperatures, depends on various factors:

- type of system
- compressors and circuits number
- maximum temporary acceptable temperature difference from set-point
- Quantity of defrost cycles necessary to proper functioning of the unit (depending on external and working conditions)
- compressors and circuits number

---

## Installation site

To determine the best installation site for the unit and its orientation, you should pay attention to the following points:

- compliance with the clearance spaces indicated in the official dimensional drawing of the unit must be guaranteed so as to ensure accessibility for routine and non-routine maintenance operations
- compliance with the respect spaces indicated in the installation, use and maintenance manual must be guaranteed, in relation to units with highly flammable A3 refrigerant
- you should consider the origin of the hydraulic pipes and their diameters because these affect the radiuses of curvature and therefore the spaces needed for installing them
- you should consider the position of the cable inlet on the electrical control panel of the unit as regards the origin of the power supply
- if the installation includes several units side by side, you should consider the position and dimensions of the manifolds of the user-side exchangers and of any recovery exchangers
- if the installation includes several units side by side, you should consider that the minimum distance between units is 3 metres
- you should avoid all obstructions that can limit air circulation to the source-side exchanger or that can cause recirculation between air supply and intake
- you should consider the orientation of the unit to limit, as far as possible, exposure of the source-side exchanger to solar radiation
- if the installation area is particularly windy, the orientation and positioning of the unit must be such as to avoid air recirculation on the coils. If necessary, we advise making windbreak barriers in order to prevent malfunctioning.

Once the best position for the unit has been identified, you must check that the support slab has the following characteristics:

- its dimensions must be proportionate to those of the unit: if possible, longer and wider than the unit by at least 30 cm and 15/20cm higher than the surrounding surface
- it must be able to bear at least 4 times the operating weight of the unit
- it must allow level installation of the unit: although the unit is installed on a horizontal base, make slopes in the support surface to convey rain water or defrost water to drains, wells or in any case to places where it cannot generate an accident hazard due to ice formation. All heat pump version units are equipped with discharge manifolds for the condensed water; these can be manifolded to facilitate condensate discharge.

The units are designed and built to reduce to a minimum the level of vibration transmitted to the ground, but it is in any case advisable to use rubber or spring anti-vibration mounts, which are available as accessory and should be requested when ordering.

The anti-vibration mounts must be fixed on before positioning the unit on the ground.

In the event of installation on roofs or intermediate floors, the pipes must be isolated from the walls and ceilings.

It is advisable to avoid installation in cramped places, to prevent reverberations, reflections, resonances and acoustic interactions with elements outside the unit.

It is essential that any work done to soundproof the unit does not affect its correct installation or correct operation and, in particular, does not reduce the air flow rate to the source-side exchanger.

---

## Definitions

For reasons of clarity, it has been deemed helpful to introduce a series of additional definitions;

- **User terminal side heat exchanger/Desuperheater**

This type of heat exchanger is used to transfer heat from or to the hydraulic circuit vector fluid and, hence, heat or cool the climate controlled environments. The desuperheater is a dedicated heat exchanger used to heat a specific hydraulic circuit. Such units normally consist of a brazed plate heat exchanger. Other types of heat exchanger may be used.

- **Source-side heat exchanger**

This type of heat exchanger is used to transfer the heat extracted from/yielded to the user terminal side hydraulic circuit vector fluid towards the outdoor air when cooling/heating the climate controlled environments. Usually, finned or micro-channel coils. Other types of heat exchanger may be used. For example, in the case of water dissipation type source units, either brazed plate or tube bundle heat exchangers may be used.

- **Refrigerant leaks**

Refrigerant gas escaping from the container/object used to store it; in the case of Chillers or Heat Pumps, the gas will escape from the refrigerating circuit or one of its components. As the refrigerants in question are flammable, under certain circumstances gas leaks may result in the formation of flammable or explosive atmospheres. Such instances include, but are not limited to:

- refrigerant gas leaks from the unit refrigerating circuit due to one of its components malfunctioning or being damaged;
- refrigerant gas leaks caused by the unit safety valve being activated;
- refrigerant gas leaks caused by the unit heat exchanger or finned battery being damaged;
- accidental release of refrigerant gas from the refrigerating circuit, or cylinders used to store the gas, during maintenance activities.

- **Installation Class (Ref EN378-1).**

The Standard defines for Installation Classes.

- **Access Category (Ref EN378-1).**

**a** = public; **b** = restricted or supervised; **c** = controlled or authorised.

- **Charge Limit (Ref EN378-1).**

The Standard defines maximum refrigerant charge limits, depending on the installation class, access category and type of refrigerant in use.

- **LFL (Ref EN378-1).**

The lowest percentage of a substance in air that can lead to flame propagation.

- **The safety class or category of a refrigerant fluid (EN 378-1).**

categorization of a substance as flammable or non-flammable, toxic or non-toxic.

- **ATEX Zone 2 (Ref. EN 60079-10-1 and IOM) and Safety Zone (Ref IOM)**

Zone 2 according to the Atex directive is an area in which the formation of an explosive atmosphere of air and flammable substances in the form of gas, vapor or mist is not likely during normal activities and, if it occurs, it is only of short duration.

- **Ignition Sources (Ref EN378-2).**

External sources that could lead to flame propagation in a combustible atmosphere.

- **Installation.**

Installation is defined as the unit positioned and installed correctly and operational as set out in the IOM manual. This definition does not include the activities involved in preparing the installation (construction of the hydraulic and electrical systems, realising the infrastructure, etc.) In addition to the reference standards, further information may be found in the Appendix to this document.

- **Electrical control panel**

Electrical control panel QE. The panel encloses all the electrical components, the terminal boards, the piloting inverters, the control boards, etc. The electrical panel has a integrated ventilation system. The panel control can be equipped with single or dual fan versions. For Electrical control panel Atex components are not mandatory.

- **Technical compartment**

Technical compartment VT. The technical compartment encloses all refrigerant circuit elements, excluding air coils for air/water units. An Atex gas sensor and Atex extraction fan are inside the technical compartment.

---

## Applicable standards and regulations

The main regulatory framework is given by the complete EN378, while for a complete regulatory framework it is useful to refer to the final part of the Swegon guides on flammable refrigerants.

EN378: refrigerating systems and heat pumps

- EN378-1: Basic requirements, definitions, classification and selection criteria.
- EN378-2: Design, construction, testing, marking and documentation.
- EN378-3: Installation site and personal protection.
- EN378-4: Operation, maintenance, repair and recovery.

## Installation types

Generally, an air conditioning unit is installed in rooms that are normally occupied by people, in general-purpose rooms or in dedicated technical room such as **machinery rooms**. Another possible option is unit installation **outdoors, in the open air**. Also, several access categories are defined for each installation. The type of installation and access category determine the maximum permitted refrigerant charge for the installation, depending on the type of refrigerant in use.

This guide specifically addresses:

- Hydronic climate control units; chillers and heat pumps for **Class III outdoor** installations (open space installations). In the case of Class III installation in open field where all the standard and manufacturer's standards relating to the installation of the unit are respected, there is no restriction on the amount of charge of the installed unit if the access category and type "c" (authorized access).
- Hydronic units for air conditioning, chillers and heat pumps for indoor installations, Class IV (ventilated enclosure). Where the installation is Class IV indoor version and complies with all statutory and manufacturer's requirements as regards unit installation, the maximum limit charge for units filled with refrigerant A3-R290 is 5 kg, with access category types "b" and "c". Please be aware that, according to Table C.1 in Annex C to standard EN 3781, installations must not be placed in spaces at higher levels that are not provided with emergency exits or in spaces below ground level as this may pose some additional restrictions in terms of minimum volume that may depend on inspections of the level of toxicity of the refrigerants in use.

For further information regarding installation classes, access categories and the charge limit, consult the Standard EN378-1.

Compliance with class III or class IV is also linked to the fact that the hydraulic system that carries the fluid that is heated or cooled by the unit to the various users complies with the requirements defined by EN 378-1 in section 5.5. 2 to avoid the possibility of a leak of refrigerant flowing into occupied rooms. See the section "Hydraulic Connections" for a description of the various solutions that are applicable to our types of unit.

Failure to comply with the provisions regarding the hydraulic system will result in the installation being downgraded to Class I or Class II, in which case the refrigerant charge limits are lower than in Class III and Class IV (Ref. EN 378-1, Annex C).

In general, **the person in charge of the installation** (generally the designer), must ensure compliance with the standard requirements by carrying out a risk assessment mainly according to the manufacturer's instructions and standards, such as EN378-1, EN378-3, or IEC 60335-2-40:2018 when applicable. All other considerations aside, the installation must also conform with the applicable local or national regulations.

**The installation technician** must install the units as defined in the project. Before starting to install the units, the installation technician must carry out his/her own assessment, within the limits of his/her technical qualifications and issue the Declaration of Conformity once the work is complete.

**The installation supervisor** is responsible for guaranteeing the conformity of the system.

**We strongly recommend** that a consultant/qualified third-party body be involved in the installation conformity assessment process, based on the type and quantity of refrigerant used.

In order to ensure complete safety of the application, it is fundamentally important to respect the type of installation the unit has been designed for.

Where more stringent than the provisions set out in the applicable regulations, the installation shall conform to the local/national regulations.

---

## Class III hydronic unit installations in open air environments

In order for the outdoor installation of units containing flammable and non-toxic refrigerant to be considered class III, the following are some of the additional assessments that the responsible for the installation (customer, installer, consultant, ...), must do to ensure that any gas leak does not generate dangerous situations.

**1.** The units must be positioned so as **to prevent any refrigerant leaks** from reaching the enclosed spaces, creating temporarily flammable zones or harming persons or property. Leaks must be prevented from flowing into manholes and storm drains and directly onto personnel and must not be directed towards air vents designated to serve enclosed spaces. Leaks must also be kept away from fresh air intakes, doors or similar openings, as well as ignition sources as defined by the Standard EN378-1. here is an obligation to convey the discharge of the safety valves via piping compliant with national and/or European directives, the area of which the refrigerant escapes must comply with the same requirements described above valid in the event of a leak.

The installation, use and maintenance manual and the dedicated documentation offer a detailed explanation of how the drainage channel must be created and calculated and any identification requirements required, but it must be remembered that the responsibility falls in any case on the person in charge of the installation.

Standard EN13136:2019 should be referenced for the calculation and sizing of the safety valve exhaust.

The conveying must be done with a pipe whose diameter must be at least that of the valve outlet, and the weight of the pipe must not be borne by the valve.

When positioning the safety valve discharge line, it should be taken into account that the Atex-Zone 2 generated by the emissions from a safety valve differs from the Atex Zone 2 defined for the unit.

More comprehensive information on the extent of Atex zone 2 at the outlet of the safety valve drain ducting can be found in the relevant instruction manual for installation, operation and maintenance of the unit.

The assessment of the risk areas is the responsibility of the installation supervisor.

Exhausted material must not be conveyed close to ignition sources, as defined in standard EN378-2.

Where the existing local regulations are more stringent, these should be taken as reference.

Always use the appropriate type of fire extinguishers for the refrigerant in use in proximity to the unit.

**2.** If the refrigerant leak can stagnate, for example, underground or inside cavities, the installation must comply with the requirements for gas detection and ventilation of engine rooms and where applicable , also compliant with the requirements for ignition sources as defined by EN378-2. Reference to the section on machinery rooms in standard EN 378-3 should be made in this case.

**3.** Where the unit is installed in the open air, but under a shelter, ventilation must be guaranteed.

**4.** If the unit installed is inside a room, where at least one of the longest walls is open to outside air for at least 80% of the wall area (or equivalent if more of a wall must be outdoors) and covered by slats/grids with at least 75% free area, is considered as an outdoor installation.

**5.** When conducting the risk assessment, the installation supervisor must also take the following indications into account.

- In the event of leaks, the unit gives rise to an Atex "zone 2" classified environment around the machine.
- Based on the above, the designation of a safety "zone/area" around the machine is deemed to be appropriate.

In a "zone 2":

- installation of equipment unsuitable for use in such potentially explosive zones must be avoided (the minimum equipment requirements are: 3G IIB T4);
- naked flames, sparks and hot work must be avoided;
- sources of ignition that are due to processes must be avoided, since they are likely to give way to remote ignition (ionizing and non-ionizing radiation);
- direct and indirect effects of electrocution must be avoided;
- electrostatic charges must be avoided;
- interference must be avoided with elements that may be hazardous, including sewage systems, openings towards stone retaining walls, underground spaces, power lines, flammable material warehouses, railways, motorways, etc.

In the safety "zone/area", storage of refrigerant bags must be avoided in spaces such as sewage systems, manholes, water traps, openings towards stone retaining walls, underground spaces, etc.

Refer to national or local regulations on this issue, where applicable.

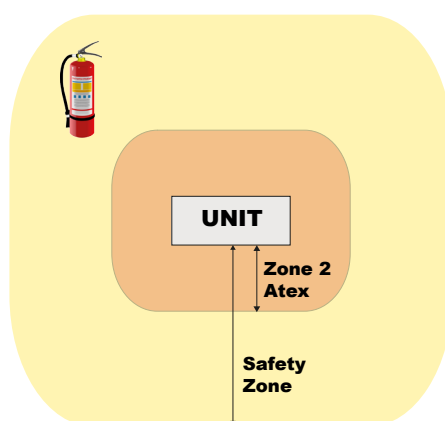

**For further details, please refer to the "Instruction manual for operation and maintenance".**

**6.** Confirm that noise barriers or other protection systems, if any, cannot create areas where leaks can stagnate.

**7.** Also take into account the possible leaks that can occur on parts of the circuit that are normally closed, for example from panels that can be removed or from doors that can be left open during maintenance activities.

Note:

To guarantee the correct functioning of the unit, it is mandatory to guarantee the clearances specified in the dimensional drawings. Always check the Atex Zone 2 and the respect/safety zone and any installation limitations in the Installation, Use and Maintenance manual.

Access restriction is part of correct installation to eliminate residual risks during normal operation.

---

## **Class IV installations (indoor units)**

In order for Class IV indoor installation of units containing flammable and non toxic refrigerant to be compliant, please find below a list of additional evaluations that the installer must make with a view to preventing refrigerant leaks, if any, from generating hazardous situations

The safety valves are always fitted and their exhaust is routed outside the closing panels. Installation requirements and/ or national legislation require that the exhaust of safety valves is ducted outside. Where this is already the case, it must be ducted away from the unit.

The conveying must be done with a pipe whose diameter must be at least that of the valve outlet, and the weight of the pipe must not be borne by the valve.

The installation, use and maintenance manual and the dedicated documentation offer a detailed explanation of how the drainage channel must be created and calculated and any identification requirements required, but it must be remembered that the responsibility falls in any case on the person in charge of the installation.

The safety valves outlet must be conveyed using pipes in compliance with the national and/or European directives: the exhaust point must not be close to trap-doors, manhole covers and any other opening where refrigerant may be contained; the drained refrigerant must not be conveyed close to fresh air inlets, doors or similar openings; the drained refrigerant must not be ducted close to ignition sources, as defined in standard EN 378-2.

Standard EN13136:2019 should be referenced for the calculation and sizing of the safety valve exhaust.

Exhausted material must not be conveyed close to ignition sources, as defined in standard EN378-2.

The assessment of the risk areas is the responsibility of the installation supervisor.

Where the existing local regulations are more stringent, these should be taken as reference.

Always use the appropriate type of fire extinguishers for the refrigerant in use in proximity to the unit.

In accordance with the definition of "ventilated enclosure", a fan is provided that prevents the air flow from reaching the room where the unit is installed and causes a forced fresh air inlet. Exhausted air flows outside through ducts that are isolated from the space where they are installed. The technical compartment in which the unit is installed must be at least 10 times the volume of the unit. Should a leak occur, the fan is started and fresh air must be able to flow into the room to offset the exhaust air. The fan must be compliant for use in explosion atmosphere (ATEX).

It is mandatory, and responsibility of the installer, to install a duct for a correct routing of the air ejected from the technical compartment into the open air. The air exhaust duct must be compliant with the requirements laid down in standard EN 378-2 6.2.15. The air duct must not present sources of ignition. It is essential to ensure that the air is not expelled in proximity to storm drains, manholes, or any other opening that may contain refrigerant; in proximity to fresh air intakes, doors or similar openings, or in proximity to ignition sources, as defined by the Standard EN378-2.

Comprehensive and detailed information, including technical data concerning the fan flow rate and head required for correct implementation of the air exhaust ducting, as well as the flow rate of fresh air to be provided in the room where the unit is installed, are available in the specific instruction manual for operation and maintenance of the relevant units.

---

## Hydraulic Connections

The chillers and heat pumps are normally used to heat and/or cool a closed water circuit connected to system terminals such as fan coils, etc., which are usually located in occupied spaces. The plumbing then connects the building utilities with the refrigeration machine, so in Class III and Class IV installations, for compliance to occur, the installer must take extra precautions to prevent a refrigerant leak into the hydraulic circuit through the heat exchanger then flows inside occupied rooms and or generates a flammable mixture, as required by EN 378-1 and EN378-3.

- The hydraulic system must be protected against accidental damage.
- An automatic air/refrigerant separator and a safety valve must be provided: these components must be installed as the first element at the outlet of the plate heat exchanger. The air/refrigerant separator and the safety valve must be placed at a higher level than the outlet of the heat exchanger where refrigerant may build up.
- Hydraulic components, accumulator tanks and any other open type components or elements that could release refrigerant as a consequence of a leak from the heat exchanger must be installed outdoors. The same safety precautions must be implemented as for any other potential source of leaks from the unit. If it is not possible to install such elements outdoors, they must be replaced with equivalent, watertight components.
- If there is a hydraulic decoupling device installed between the primary and secondary circuits, assess whether it is sufficient to implement the above precautions to the primary circuit only.

Outdoor installation always requires the fitting of safety valves. The air/refrigerant separators must be installed in an outdoor space. The option exists to evaluate installation of these components indoors, provided that in such case the air exhausted from these components must be ducted outside. The installer shall carry out a flammability assessment and a classification of the danger zone in the exhaust area, as required by standard EN 378-3. In the event that the installation solutions defined in the previous points are not possible but these devices are confined within a machine room, it is the duty of the installation manager to carry out a flammability assessment and classification of the danger area for the room technical as required by the EN378-3 standard".

The precautions implemented on the desuperheater hydraulic circuit must be the same as those adopted for the main heat exchanger.

All the units in heat pump version are equipped, at the base of each condensing/evaporating coil, with a condensate drip tray provided with an electric heater

If refrigerant leaks from the condensing coils, it may flow out through condensate pipework. Do not duct the refrigerant in pits, downpipes or any other opening where the refrigerant may build up and/or flow to sources of ignition, as defined in EN 378-2.

---

## Guidelines for the risk assessment

The purpose of this section is to provide all elements specific to the Swegon Operations S.r.L. production units. with A2, A2L and A3 refrigerants to allow the installation manager to carry out the risk assessment associated with the installation and, consequently, to determine the prevention, protection and management measures to be adopted to pursue the following safety objectives:

- minimise the causes of fires or explosions;
- guarantee the stability of the supporting structures for a predetermined period of time;
- limit the instance and spread of fires inside the building;
- limit the spread of fires to adjacent buildings;
- limit the effects of explosions;
- ensure that occupants are able to leave the building unassisted or receive assistance in other ways;
- ensure that emergency services are able to intervene in conditions of safety.

The installation supervisor is responsible for compiling the installation risk assessment.

The information is in accordance with the European standard EN378 with particular reference to the effects on the environment and on the safety of people and things in the context linked to the installation of Swegon Operations S.r.L. production units. containing refrigerants classified A2L, A2 and A3.

The Technical Handbook includes information regarding the manufacturing specifications, technical and performance data, available accessories and all the other elements necessary for a full understanding of the units.

The Installation, Operating and Maintenance manual contains the information necessary to install, operate and service the units.

The technical data label, the additional labels, the wiring diagram, the refrigeration diagram, the hydraulic diagram, the dimensional diagram, the instructions concerning handling and the accompanying documentation show technical data, dimensions, clearances, data and electrical characteristics and hydraulics, utility connections, handling information and much more.

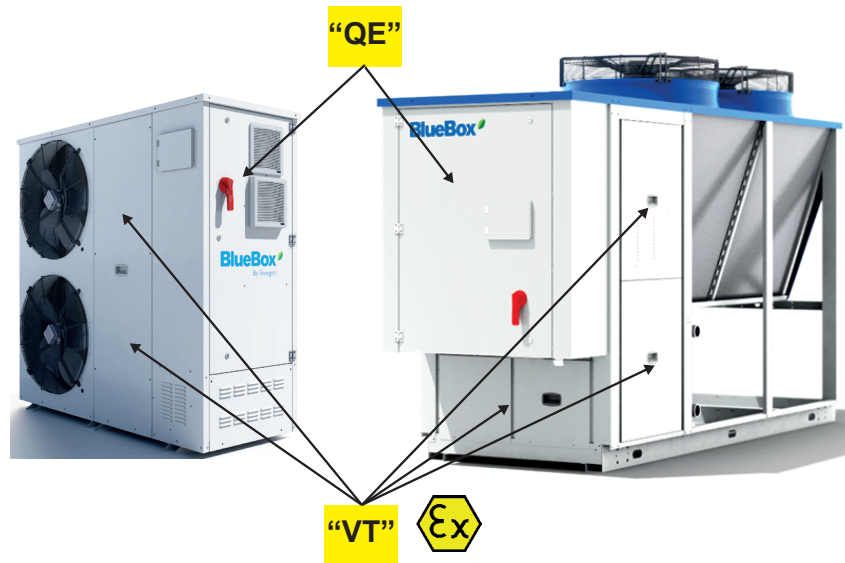

Thus, when defining the project and conducting the risk assessment, it is necessary to take various situations into account, including:

- how to properly convey any gas exhausted by the safety valves and how any leakage from the coils or any exhaust from the technical compartment (VT) may be made to flow to the safe area, as described above;
- a check that any leak in the "VT" is sensed by the refrigerant sensor a the time when the concentration exceeds 10% the LFL. The three-phase power supply is cut out and the unit consequently switches off. The extraction fan in the "VT" is started so that the air-refrigerant mix is expelled to the outside. The fans in the electric panel (QE) are switched on, if they are not already. The rest of the unit is off and the safety device chain only is active. The unit reports the leak condition by means of a light indicator and through a potential-free contact. After the leak is cleared safely, the sensor requires resetting, which is done by cutting out power to the sensor. When the sensor is energised again, a "warm-up" procedure gets started. A reading test is recommended after a leak has been identified;
- where a leak external to the "VT", originating from the unit batteries, is not detected by the refrigerant sensor but is prevented from entering the "QE" due to it being isolated. If the leak were to reach the axial fans, the speed of the air and effect of dilution would cause it to be dispersed. If the leaking gas manages to access the "VT", the previous case applies;
- if the sensor experiences a malfunction or power to it is cut out, but the unit is energised, the system basically starts the same actions listed for any leakage detected inside the "VT". Dedicated warning lights/messages are activated in this case, which are different from those relating to a leak;
- a blackout of the three-phase line switches the entire unit off, safety device chain included;
- a short blackout does not normally require an inspection by a qualified technician before the power line is restored;
- if the power failure lasts for a long time, we strongly recommend that a skilled technician be asked to test the unit for leaks on site: this evaluation must be part of the risk analysis;
- in any case, as soon as power is restored, the sensor runs the warm-up procedure, at the end of which an OK signal is output, where no leaks are identified, to restore power to the rest of the unit.

Despite the requirements adopted in units containing A3 flammable refrigerants, and although some components may be ATEX compliant, Swegon Operations units containing A3 **refrigerants are not suitable** to be installed in explosive environments as required by the ATEX directive.

---

## Installation risk assessment

Transport, positioning and storage are not included in the scope of the installation risk assessment. The section "Reception, handling and storage of units containing flammable refrigerants" of this document provides information of performing these phases correctly and as safely as possible.

The residual risks described in the Installation, Operating and Maintenance manual must also be taken into account when conducting the risk assessment.

The following table contains a series of indications designed to assist the installation supervisor in conducting the risk assessment, and in minimising the risks themselves.

How to minimise fire risks in the installation.

Installing the unit	<p>The unit must be installed in a workmanlike manner, by a certified and titled company, respecting the manufacturer's specific instructions given in the IUM manual and adopting all the necessary fire prevention, protection and management measures.</p> <p>The unit must be installed outdoors in such a way as to prevent any refrigerant leaks from reaching the enclosed spaces, creating temporarily flammable zones or harming persons or property. Suitable fire extinguishing systems, corresponding to the type of refrigerant in use, must be installed in the vicinity of the unit.</p>
Ignition sources	<p>There <b>must not</b> be any ignition sources present <b>inside</b> the Atex Zone 2 of the unit, if such a zone is defined for the unit/installation being assessed. If no Atex Zone 2 is defined, the installation supervisor is responsible for assessing the presence/vicinity or otherwise of ignition sources, depending on the type of unit, the refrigerant in use, the installation, etc.</p>
Refrigerant stagnation areas	<p>There <b>must not</b> be any refrigerant stagnation areas, where refrigerant could be trapped in the event of a leak, present <b>inside</b> the unit safety zone.</p>

---

## Refrigerant leaks

From the unit refrigerating circuit.

The unit refrigerating circuit, which is housed inside the technical compartment, is fitted with a refrigerant detector that is tripped if the concentration exceeds 10% of the LFL. The technical compartment is purged by expelling the refrigerant, which mainly builds up under the finned coils. The refrigerant is expelled by means of Atex fans. **The Atex Zone 2 and Safety zone must be respected.**

From the source side heat exchanger.

The leak is external to the unit and, if it does not enter the technical compartment, the unit continues to operate. In this case, the electrical components in the technical compartment are not affected by the leak. The leak cannot reach the electrical panel if the installations specifications have been respected. It should be taken into account the fact that, if the installation is located nearby marine environments or in the presence of aggressive atmospheres, and the coils are not treated accordingly, there is a greater chance of leaks. **If defined, the Atex Zone 2 and Safety zone must be respected.**

From the user terminal side heat exchanger.

The refrigerant leak flows from the refrigerating circuit towards the hydraulic system via the heat exchanger. The leak is not detected and the unit continues to operate. It **is obligatory** to respect the provisions relating to the hydraulic system. If the installation includes vents or deaerators, the risk assessment may also involve defining specific Atex 2 zones.

From the safety valve vent.

Correct discharge of the refrigerant vented by the safety valves plays a **fundamental** role in minimising fire risks. Such leaks must be routed as set out in the IOM manual, taking into account the fact that the outlet of the discharge line gives rise to an additional **Atex 2 Zone, which must also be respected**

External to the unit but not deriving from it

The unit is not suitable for use in flammable atmospheres. The leak must be detected as set out in the applicable standards and the unit made safe; for example, the unit must be completely isolated from its electrical power supply until the fault has been corrected and the flammable atmosphere eliminated.

#B#Main procedures that should be adopted:

- The use of either forced or natural ventilation helps to dilute the refrigerant and dissipate it in the surrounding air more rapidly.
- The electrical power supply to all devices not designed to be operated in flammable atmospheres should be interrupted if they are affected by the leak.
- All potential ignition sources that may be affected by the leak must be removed, if present.
- Avoid creating areas where build ups of refrigerant may accumulate, resulting in localised zones where flammable atmospheres may be present.
- Refrigerant must be prevented from reaching closed or occupied spaces, fresh air intakes, windows and other openings.
- The refrigerant Propane-R290 is heavier than air, which means that it tends to build up close to ground level.
- Additional safety procedures may be implemented, depending on the specifics of the individual installation site.

---

*Unit refrigerant detector fault* When a detector fault is identified, the unit enters safe mode, disconnecting all the electrical components not designed to be operated in flammable atmospheres from their power supply. The unit stops working. Only the technical compartment extractor fans, the electrical panel cooling fans and the leak sensor remain energised. This is **not** a leak condition, but it is necessary to check the refrigerant detector and restore correct operation as soon as possible.

*Generic unit fault* A generic fault does not give rise to a refrigerant leak. A fault that does give rise to a leak falls with the description provided above.

*Fault on the extractor fan* The unit handles a potential refrigerant leak in safe mode, as described above, disconnecting all the electrical components not designed to be operated in flammable atmospheres from their power supply. Refrigerant leaks from the technical compartment are slower, but spread to all parts of the compartment, rather than being concentrated mainly under the finned coil. **If defined, the Atex Zone 2 and Safety zone must be respected.**

It is important to recall that, when installing units containing A3 classified refrigerants, it may be necessary to obtain permission from the relevant Authority.

---

*Electrical power supply  
absent*

Since it is not energised, the unit is safe, meaning that any leaks that may occur in this condition cannot come into contact with potential ignition sources. In this condition, the refrigerant sensor and the Atex extractor fan are deactivated. When the unit is switched on again, check there is no refrigerant present before supplying the rest of the unit. **If defined, the Atex Zone 2 and Safety zone must be respected.**

*Presence of flammable  
material*

The presence of flammable material is prohibited within the Safety zone. Check the refrigerant safety data sheet to assess which other substances may represent a hazard if they come into contact with the refrigerant.

---

## Suggestions for conducting and drawing up the risk assessment

This section contains an example that highlights the possible requirements to be complied with and the minimum information that must be filled in by the installation manager when drafting the risk assessment for a typical installation. The abbreviations describe the contents to be inserted in the various columns.

- **App.** = applicability of the provision (complete the empty fields according to the type of installation).
- **A** = the provision is applicable. It is possible to indicate a limit, a threshold, a distance, etc. that must be respected. If no indications are present, the provision is applicable but it is not necessary to respect any limits. For example, if an Atex zone 2 is defined, there is a minimum distance to respect and this is the limit to indicate, while in the case of the presence of fire extinguishers, it is sufficient that the fire extinguishers are present, therefore there is no limit to indicate. **Attention:** where they are more stringent, always refer to the local regulations for clarification regarding the applicability of the provisions. Since they are applicable for this type of installation, certain provisions are already indicated as applicable in the following example.
- **Conf.** = prescription compliance. Indicate whether the prescription is complied with or not. All non-conformities must be described in detail in the list at the bottom of the table, in correspondence with the number of the note specified when assigning responsibility for the non-conformity.
- **Doc.** = prescription reference document (fill in the empty fields in accordance with the assessment specifying any additional documents).
- **Note** = indicate a note reference, to be included in the footer list with explanation of the item, if necessary. It is also possible to insert a brief description in the case of applicability and conformity.

The risk assessment must include the following fields:

- Name of the installation site.
- Town/City.
- Address.
- Proprietor.
- Intended use.
- Person responsible for the risk assessment.
- Date.

It is also useful to include a list of the principal reference documents that should be adopted when drawing up the risk assessment (complete with the respective abbreviations).

The following documents constitute an integral part of the machine documentation. The documents are indicated by the abbreviations used to refer to them in the risk assessment.

- **IOM:** Installation, Operating and Maintenance manual This is the document where it is possible to find information relating to product safety and the correct way of operating, information on installation, Atex zone 2, safety zone and on the specific prescriptions relating to flammable refrigerant, start-up and maintenance of the units, as well as information on the competent personnel who may operate. This document is essential for personnel assigned install and operate the unit.
- **DimDiag:** The dimensions diagram illustrates the physical dimensions of the unit and the respective operating spaces.
- **ELDiag:** The electrical circuit diagram includes all the information regarding the unit electrical connections and the external connections to the unit.
- **Declaration of Conformity:** this document indicates the various EEC Directives and Regulations the unit conforms to.
- **PDoc:** an assessment conducted by the installation technician or other personnel responsible for the installation site.
- **TH:** Technical handbook or catalogue This document covers the technical and electrical data, the hydronic units and pumps; it includes the unit operating limits and various other information. This document is essential when designing a unit installation, especially in the case of projects that include units containing flammable refrigerants.

It is important to recall that, when installing units containing A3 classified refrigerants, it may be necessary to obtain permission from the relevant Authority.

So the risk assessment could be drafted as follows and contain, for example, the following information:

<b>Unit model: .....</b>	<b>App.</b>	<b>Doc.</b>	<b>Conf.</b>		<b>Notes</b>
<b>Serial No.: SB.....</b>			<b>Yes</b>	<b>No</b>	
<b>Type of Refrigerant: .....</b>					
<b>Quantity of refrigerant (kg):</b>					
<b>Circuit 1 = .....</b>					
<b>Circuit 2 = .....</b>					
<b>Circuit 3 = .....</b>					
<b>Circuit 4 = .....</b>					
<b>Classification (A2L, A3, Other): .....</b>					
<b>Installation specifications.</b>					
Operative clearance spaces - single unit.	A	SchDI			
Operative clearance spaces - adjacent units.	A	IOM			
ATEX 2 Zone Refrigerant leak - refrigerating circuit.	A	IOM			
ATEX 2 Zone Safety valves discharge: horizontal.	A	IOM			
ATEX 2 Zone Safety valves discharge: vertical.	A	IOM			
Safety zone.	A	IOM			
Type of installation (indicate class and access category).	A	IOM			
Charge limit (indicate charge limit value).	A	EN378-1			
Access to the area around the unit is restricted to qualified personnel only.	A	IOM			
Fire extinguishers suitable for use on Propane in the vicinity of the unit.	A	IOM			
		EN378-3			
Ventilation guaranteed.	A	IOM			
		EN378-3			
It is forbidden to smoke or carry out any activities that involve introducing ignition sources into the ATEX 2 zone.	A	IOM			
		EN378-3			
Presence of one or more emergency circuit breakers for interrupting the power supply to the unit.		EN378-3			
Presence of refrigerant detectors in the installation (indicate trip setting level and area covered).					
Refrigerant leaks must not occur in the vicinity of ignition sources, fresh air inlets, closed and/or occupied spaces, doors or similar openings, manholes, storm drains or any other opening that could contain the refrigerant.		IOM			
		EN378-3			
The installation site conforms to the fire prevention directives (indicate reference document).					
The escape routes must conform to the requirements of the fire prevention directive (indicate reference document).					
Other, depending on the characteristics of the installation.					
<b>Unit safety valves.</b>					
Safety valve discharge line.	A	Pdoc			

Unit model: .....	App.	Doc.	Conf.		Notes
Serial No.: SB.....			Yes	No	
i. Manufactured according to IUM, dimensional scheme and national directives.	A	IOM			
ii. Inner diameter not less than the diameter of the safety valve outlet.	A	SchDI			
iii. The weight of the pipe must not weigh on the safety valve.	A	IOM			
iv. Sealed from the surrounding environment.	A	IOM			
	A	EN378			
v. There must be no sources of ignition inside the exhaust pipe.	A	IOM			
	A	EN378			
vi. Calculation and sizing of the drain.	A	EN13136:			
	A	2013			
vii. Escaping refrigerant must not be in the vicinity of sources of ignition, fresh air intakes, confined and/or occupied spaces, doors or similar openings of drains, manhole covers and any other openings which may contain refrigerant.	A	IOM			
		EN378-3			
viii. The drain must not cause damage to people or things.	A	IOM			
		EN378-3			
<b>Unit equipment.</b>					
Installing accessories.					
• Accessories suitable for use in flammable atmospheres.		Pdoc			
• Accessories not suitable for use in flammable atmospheres.		Pdoc			
• Other, according to unit configuration.					
Unit equipped with refrigerant leak sensor.	A	IOM			
• Read/run check at start up.	A	IOM			
• Periodic reading/operation check.	A	IOM			"e.g.(2)"
Unit equipped with ATEX cable glands.	A	IOM			
• Start-up tightening check.	A	IOM			
• Periodic tightening check.	A	IOM			

Unit model: .....	App.	Doc.	Conf.		Notes
Serial No.: SB.....			Yes	No	
<b>Hydraulic circuits 1</b>					
Hydraulic circuit in conformity with EN378-32.	A	IOM EN378-3			
• It is compulsory to use systems in the hydraulic system capable of eliminating the presence of refrigerant gas in the event of a leak (vents, safety valves, degassers, other). These systems must be outside or safely conveyed outside according to requirements similar to points <b>iv, v, vii and viii</b> of the item "safety valve discharge".	A	IOM EN378-3			
• The conveying pipe, if present, must be correctly sized and made according to the indications of the reference standard.	A	Pdoc			
• Open-type components connected to the plumbing system must be installed outdoors or replaced by sealed equivalents.	A	IOM EN378-3			
• Comply with the Atex zone 2 of the vents or safety valves of the hydraulic system (indicate the Atex Zone 2 limit).	A	Pdoc			
• Respect zone 2 Atex open components of the hydraulic system installed outdoors (indicate Zone 2 Atex limit).	A	Pdoc			
• Comply with Atex Zone 2 due to loss of refrigerant from the hydraulic system (indicate Atex Zone 2 limit).	A	Pdoc			
• Other, according to the characteristics of the hydraulic system.	A	Pdoc			
<b>Electrical connections.</b>					
The electrical connections must be realised in a professional manner by operators who are qualified to design and install electrical systems, in accordance with applicable international and national standards.	A	IOM			
The system must be connected to earth.	A	IOM SchEL			
Power supply voltage and frequency corresponding to the electrical data specified for the unit (indicate nominal values).	A	IOM			
The weight of the cables must not be borne by the electrical connection system.	A	SchEL			
The cross-section of the cable and the line protection devices must correspond to those indicated in the wiring diagram.	A	IOM			
The passage of any cable from the outside to the inside of the electrical panel must only take place using cable glands suitable for the diameter of the cable; any free cable glands available in the electrical panel are suitable. Do not insert more than one cable per gland; do not use sheaths inside the cable glands.	A	SchEL			
The electrical panel must not be drilled, modified or tampered with in any way; do not leave any apertures.	A	IOM			
<b>Additional provisions regarding the installation site</b>					
...					
<b>Other</b>					
...					

---

## Installations that require the use of treated coils

If the unit has to be installed in an environment with a particularly aggressive atmosphere, coils with special treatments are available as options.

- e-coated microchannel coils (accessory not available for HP units)
- coils with anti-corrosion treatment (accessory available only for HP units or with Cu/Al coil)

A description of the individual accessories is available in the "Description of accessories" section.

The type of coil treatment should be chosen with regard to the environment in which the unit is to be installed, through observation of other structures and machinery with exposed metal surfaces present in the destination environment.

The cross observation criterion is the most valid method of selection currently available without having to carry out preliminary tests or measurements with instruments. The identified reference environments are:

- coastal/marine
- industrial
- urban with a high housing density
- rural

Please note that in cases where different conditions co-exist, even for short periods, the choice must be suitable for preserving the exchanger in the harsher environmental conditions and not in conditions between the worst and best situation.

Particular attention must be given in cases where an environment that is not particularly aggressive becomes aggressive as a consequence of a concomitant cause, for example, the presence of a flue outlet or an extraction fan.

We strongly suggest choosing one of the treatment options if at least one of the points listed below is verified:

- there are obvious signs of corrosion of the exposed metal surfaces in the installation area
- the prevailing winds come from the sea towards the unit
- the environment is industrial with a significant concentration of pollutants
- the environment is urban with a high population density
- the environment is rural with the presence of organic discharges and effluents

In particular, for installations near the coast, the following instructions apply:

- **for installations between 1 and 20 km from the coast of units with microchannel coil, we strongly recommend using the accessory "E-coated microchannel coils"**
- **for installations between 1 and 20 km from the coast of reversible units or units with Cu/Al coils, is strongly recommended using the accessory "Coil treated with anti-corrosion paints"**

To protect the exchangers from corrosion and ensure optimal operation of the unit, we advise following the recommendations given in the user, installation and maintenance manual for cleaning the coils.

## Aeraulic head losses and options available for the ventilating section

With the exception of units for which oversize fans are required, as standard, the units are designed considering that, at the nominal air flow rate, the fans work with null available pressure.

If there are obstacles to free air flow, you should consider the additional aeraulic head losses that will cause a reduction of the air flow rate and a consequent deterioration of performance.

The following diagrams show the trend of cooling capacity (PC), EER, total absorbed power (Pabs) and reduction of the maximum external air temperature in chiller operating mode, depending on the aeraulic head losses that the fans will have to overcome.

### AC fans (Ø 800)

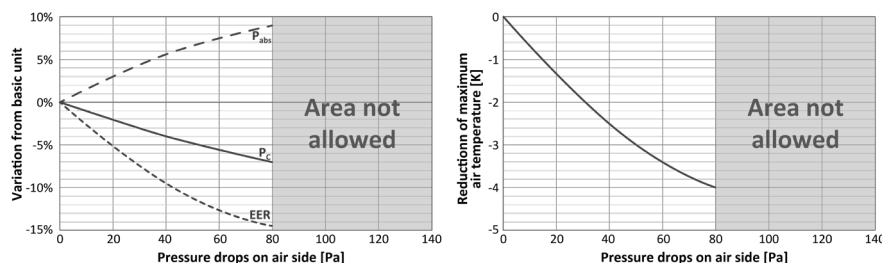

### EC fans (Ø 800)

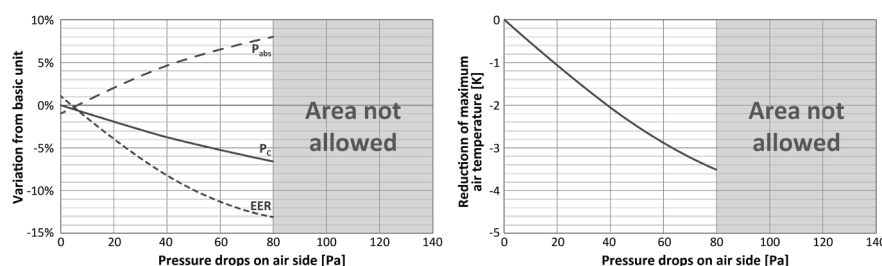

### Oversize EC fans (Ø 800)

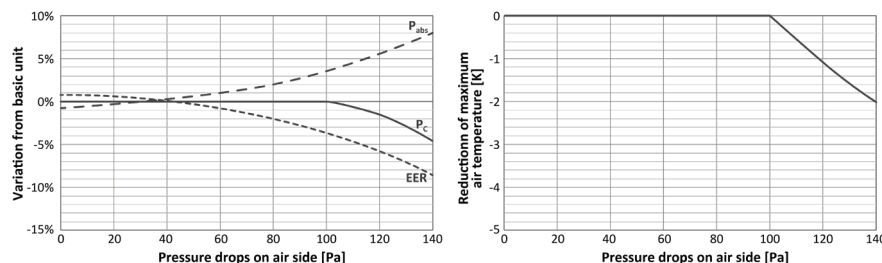

The indicated values are for the standard machine, without accessories, with AC fans and in any case in the absence of air recirculation.

Example: supposing you expect there to be obstacles that will generate an estimated aeraulic head loss of 60Pa. In this case, there are 3 possibilities:

- use the unit with standard AC fans: compared to ideal conditions, the output power will be reduced by about 5.5%, the total absorbed power will increase by about 7.5%, the EER will be reduced by about 12.5% and the maximum allowed external air temperature for operation at 100% will be reduced by about 3.4K compared to the nominal limit
- use the unit with EC fans: compared to the unit with AC fans working in ideal conditions, the output power will be reduced by about 5%, the total absorbed power will increase by about 6.5%, the EER will be reduced by about 11.5% and the maximum allowed external air temperature for operation at 100% will be reduced by about 2.8K compared to the nominal limit
- use the unit with oversize EC fans: compared to the unit with AC fans working in ideal conditions, the output power of the unit will be unchanged, the total absorbed power will increase by about 1%, the EER will be reduced by about 2% and the maximum external air temperature will remain the one shown in the diagram of the operating limits.

---

---

**Swegon Operations s.r.l.**

Via Valletta, 5 - 30010

Cantarana di Cona, (VE) Italy - T. +39 0426 921111 - F. +39 0426 302222

[www.blueboxcooling.com](http://www.blueboxcooling.com) - [info@bluebox.it](mailto:info@bluebox.it)



Swegon Operations s.r.l. a socio unico - P.IVA 02481290282

Company directed and coordinated by Investment Latour (Sweden)