

Air conditioning fan heaters with ON/OFF motor

AREO 8 - 101 kW



Hygrothermal comfort in the industrial and commercial sectors

In line with recent regulatory developments regarding energy efficiency, Galletti is updating its offering of fan heaters for heating and cooling systems to be used in industrial and commercial environments of any volume. The new AREO, which was designed to meet the stringent requirements of the ERP Directive, retains unchanged the distinctive aspects of the original design, that is, extreme reliability and sturdiness.

AREO's cover, which is made of pre-painted steel sheet, possesses an original design with a rounded shape that enhances its aesthetic form.

The AREO range consists of 16 models that, limited to the only heating version, can be either wall mounted (horizontal air flow) or ceiling mounted (vertical air flow). The cooling version is equipped with a new system in order to collect condensation and further insulation inside the cover.

The units are available in 6 sizes with 2-, 3- or 4-row heat exchangers ensuring an efficient performance with hot water supplied by a boiler or heat pump (4-row models).



2 pipes systems



Vertical installation



Horizontal installation (not for AERO C)



Heating



Cooling (only for AERO C)

PLUS

- » Low sound levels
- » Wide operating range (up to 60 °C intake air)
- » Axial fan with blades with an aerodynamic profile (HyBlade® technology)
- » Electric motor, class F, approved for continuous operation
- » Wide operating range (up to 60 °C intake air)



AVAILABLE VERSIONS

Single-phase and three-phase power supply.

AREO P

Fan heaters for hot water heating, with side water connections.

AREO H

Fan heaters for hot water heating, with vertical water connections, for replacement of indoor units installed in existing systems.

AREO L

Fan heaters for hot water heating, equipped with air-curtain diffuser, ceiling mounted.

AREO C

Single phase power supplied fan heaters suitable either for heating or cooling mode, equipped with asynchronous electric motor and side water connections, wall mounted.

MAIN COMPONENTS
Fan drive assembly

The motor and fan are a single integrated unit optimized to achieve maximum aeraulic efficiency. In fact, conformity to ERP is guaranteed, even for the versions with single-phase power supply.

Electric motor

Tropicalized motor directly coupled to an external rotor, standard, with the following features:

- equipped with internal thermal protection
- windings in class F
- protection rating IP54
- maintenance-free ball bearings

Axial fan

With blades with an optimized aerodynamic profile (HyBlade® technology), statically balanced, inserted in a housing that enhances aeraulic performance and minimizes noise.

Cabinet

Made of pre-painted steel sheet, complete with ABS corners, and manually adjustable aluminum baffles located on the air outlet for optimum distribution in the room to be heated.

Safety cage

Made of electrogalvanised steel wire, it supports the motor and is fixed to the cabinet by means of vibration-damping supports.

Heat exchanger

Made of copper pipes and aluminium fins of high thermal conductivity to optimize heat exchange.

RVM regulator for ventilation speed adjustment in single phase power supplied models

The speed regulator RVM can vary the effective value on the load by controlling the wave shape caused by a TRIAC. This accessory can be used only coupled to single phase power supplied models, and allows a fan heater manual ventilation speed adjustment depending on different needs. The device is also equipped with special filters in order to suppress noise induced on the supplied line or irradiated from the equipment and a minimum speed manually adjustable trimmer. This accessory is yet included with AREO C cooling series.

ACCESSORIES
Electromechanical control panels

CST	Delta/star switch for installation in electrical box
CSTP	Delta/star switch with box wall mounted
RVM	RVM manual power regulator for monophas power supply FAN HEATERS
TA2	Electromechanical room thermostat with summer/winter selection

Power interface and regulating louver controllers

CSD	Recess mounted controller for opening and closing the SM motor-driven regulating louver
------------	---

Accessories

VA	Auxiliary tray for collecting condensate
-----------	--

Fixation templates

DFC	Template for column installation
DFO	Adjustable template for wall/column installation

DFP	Template for wall installation
------------	--------------------------------

Protective grill for gyms (ball shield)

R	Protective net for gyms
----------	-------------------------

Diffusors

DO	Two-row adjustable fin diffuser
LA	Air curtain diffuser

External air intake

PAE	External air intake
PAEM	Manual mixing louver
PAEMM	Motor driven mixer louver, 24 V power supply with spring return

External air intake rain protection grille

GR	Air intake grille with subframe
-----------	---------------------------------

Fan heaters AREO

RATED TECHNICAL DATA AREO P - HEATING MODE

AREO P			12	12	13	13	14	14	
Power supply		V-ph-Hz	230 - 1 - 50						
no. of poles			4	6	4	6	4	6	
Motor connctions			Mono	Mono	Mono	Mono	Mono	Mono	
Rated air flow		m³/h	1280	1000	1140	900	1040	800	
Heating capacity	(1)	kW	9,77	8,48	12,4	10,7	14,2	11,9	
Water flow	(1)	l/h	863	749	1097	946	1252	1047	
Water pressure drop	(1)	kPa	29	23	22	17	17	12	
Sound power level	(2)	dB(A)	64	59	64	59	65	60	
Power input		W	69	49	69	50	70	51	

AREO P			22	22	23	23	24	24	
Power supply		V-ph-Hz	230 - 1 - 50						
no. of poles			4	6	4	6	4	6	
Motor connctions			Mono	Mono	Mono	Mono	Mono	Mono	
Rated air flow		m³/h	3020	2100	2630	1850	2600	1800	
Heating capacity	(1)	kW	19,9	16,2	25,6	20,6	28,9	22,9	
Water flow	(1)	l/h	1754	1432	2256	1820	2555	2022	
Water pressure drop	(1)	kPa	23	16	29	20	19	13	
Sound power level	(2)	dB(A)	76	64	76	65	77	65	
Power input		W	198	110	210	114	212	120	

AREO P			32	32	32	33	33	33
Power supply		V-ph-Hz	230 - 1 - 50	400 - 3 - 50	400 - 3 - 50	230 - 1 - 50	400 - 3 - 50	400 - 3 - 50
no. of poles			4	4	6	4	4	6
Motor connctions			Mono	Delta	Star	Mono	Delta	Star
Rated air flow		m³/h	4500	4300	3200	4150	4000	2900
Heating capacity	(1)	kW	35,6	34,7	29,2	39,5	38,6	31,8
Water flow	(1)	l/h	3143	3060	2579	3486	3411	2806
Water pressure drop	(1)	kPa	20	19	14	18	17	12
Sound power level	(2)	dB(A)	76	76	69	76	76	69
Power input		W	320	315	175	340	330	180

AREO P			34	34	34	42	42	42
Power supply		V-ph-Hz	230 - 1 - 50	400 - 3 - 50	400 - 3 - 50	230 - 1 - 50	400 - 3 - 50	400 - 3 - 50
no. of poles			4	4	6	4	4	6
Motor connctions			Mono	Delta	Star	Mono	Delta	Star
Rated air flow		m³/h	4050	3900	2800	6900	7100	5600
Heating capacity	(1)	kW	45,1	44,0	35,6	53,4	54,3	47,4
Water flow	(1)	l/h	3980	3886	3145	4718	4793	4185
Water pressure drop	(1)	kPa	29	28	19	37	38	30
Sound power level	(2)	dB(A)	77	77	70	75	73	67
Power input		W	345	340	182	623	650	450

AREO P			43	43	43	44	44	44
Power supply		V-ph-Hz	230 - 1 - 50	400 - 3 - 50	400 - 3 - 50	230 - 1 - 50	400 - 3 - 50	400 - 3 - 50
no. of poles			4	4	6	4	4	6
Motor connctions			Mono	Delta	Star	Mono	Delta	Star
Rated air flow		m³/h	6400	6550	5300	6200	6400	5150
Heating capacity	(1)	kW	59,6	60,4	53,2	66,8	68,1	59,5
Water flow	(1)	l/h	5259	5329	4695	5894	6009	5250
Water pressure drop	(1)	kPa	36	37	30	23	24	19
Sound power level	(2)	dB(A)	74	74	68	75	75	69
Power input		W	635	690	465	655	700	470

- (1) Water temperature 85°C / 75°C, air temperature 15°C - 100% of the max speed
 (2) Sound power measured according to standards ISO 3741 - 100% of the max speed

RATED TECHNICAL DATA AREO P - HEATING MODE

AREO P			53	53	53	54	54	54
Power supply		V-ph-Hz	230 - 1 - 50	400 - 3 - 50	400 - 3 - 50	230 - 1 - 50	400 - 3 - 50	400 - 3 - 50
no. of poles			6	4	6	6	4	6
Motor connections			Mono	Delta	Star	Mono	Delta	Star
Rated air flow		m ³ /h	6200	7900	6450	5900	7600	6200
Heating capacity	(1)	kW	60,8	70,2	62,3	66,2	77,4	68,3
Water flow	(1)	l/h	5373	6202	5497	5852	6834	6033
Water pressure drop	(1)	kPa	19	25	20	21	27	22
Sound power level	(2)	dB(A)	69	76	72	71	77	73
Power input		W	374	732	775	380	755	780

AREO P			63	63	63	64	64	64
Power supply		V-ph-Hz	230 - 1 - 50	400 - 3 - 50	400 - 3 - 50	230 - 1 - 50	400 - 3 - 50	400 - 3 - 50
no. of poles			6	6	8	6	6	8
Motor connections			Mono	Delta	Star	Mono	Delta	Star
Rated air flow		m ³ /h	8100	8300	6500	7500	7650	6000
Heating capacity	(1)	kW	99,7	101	86,4	99,6	101	85,8
Water flow	(1)	l/h	8802	8943	7626	8795	8913	7571
Water pressure drop	(1)	kPa	29	30	23	29	29	22
Sound power level	(2)	dB(A)	65	72	67	71	72	67
Power input		W	560	575	380	582	590	390

- (1) Water temperature 85°C / 75°C, air temperature 15°C - 100% of the max speed
 (2) Sound power measured according to standards ISO 3741 - 100% of the max speed

RATED TECHNICAL DATA AREO C - HEATING MODE

AREO C			12	12	13	13	14	14	22	22
Power supply		V-ph-Hz	230 - 1 - 50							
no. of poles			4	6	4	6	4	6	4	6
Air flow rate max heating		m ³ /h	1280	1000	1140	900	1040	800	3020	2100
Heating capacity	(1)	kW	9,77	8,48	12,4	10,7	14,2	11,9	19,9	16,2
Water flow	(1)	l/h	863	749	1097	946	1252	1047	1754	1432
Water pressure drop	(1)	kPa	29	23	22	17	17	12	23	16
Sound power level	(2)	dB(A)	64	59	64	59	65	60	76	64
Power input	(3)	W	67	49	69	50	70	51	198	110

AREO C			23	23	24	24	32	33	34	42
Power supply		V-ph-Hz	230 - 1 - 50							
no. of poles			4	6	4	6	4	4	4	4
Air flow rate max heating		m ³ /h	2630	1850	2600	1800	4500	4150	4050	6900
Heating capacity	(1)	kW	25,6	20,6	28,9	22,9	35,6	39,5	45,1	53,4
Water flow	(1)	l/h	2256	1820	2555	2022	3143	3486	3980	4718
Water pressure drop	(1)	kPa	29	20	19	13	20	18	29	37
Sound power level	(2)	dB(A)	76	65	77	65	76	76	77	75
Power input	(3)	W	210	114	212	120	320	340	345	623

AREO C			43	44	53	54	63	64
Power supply		V-ph-Hz	230 - 1 - 50					
no. of poles			4	4	6	6	6	6
Air flow rate max heating		m ³ /h	6400	6200	6200	5900	7695	7500
Heating capacity	(1)	kW	59,6	66,8	60,8	66,3	79,3	99,6
Water flow	(1)	l/h	5259	5894	5373	5852	8802	8795
Water pressure drop	(1)	kPa	36	23	19	21	29	29
Sound power level	(2)	dB(A)	74	75	69	71	69	71
Power input	(3)	W	635	655	374	380	560	582

- (1) Water temperature 85°C / 75°C, air temperature 15°C - 100% of the max speed
 (2) Sound power measured according to standards ISO 3741 - 100% of the max speed
 (3) Referred to maximum speed

RATED TECHNICAL DATA AREO C - COOLING MODE

AREO C			12	12	13	13	14	14	22	22
Power supply		V-ph-Hz	230 - 1 - 50							
no. of poles			4	6	4	6	4	6	4	6
Air flow rate max cooling		m ³ /h	898	898	808	808	718	718	1602	1602
Heating capacity	(1)	kW	7,87	7,87	10,0	10,0	11,2	11,2	13,4	13,4
Water flow	(1)	l/h	695	695	884	884	988	988	1184	1184
Water pressure drop	(1)	kPa	18	18	13	13	10	10	9	9
Total cooling capacity	(2)	kW	2,30	2,30	2,82	2,82	3,15	3,15	3,61	3,61
Sensible cooling capacity	(2)	kW	1,81	1,81	2,23	2,23	2,45	2,45	3,08	3,08
Water flow	(2)	l/h	395	395	482	482	541	541	620	620
Water pressure drop	(2)	kPa	9	9	6	6	5	5	4	4
Sound power level	(3)	dB(A)	53	54	53	54	54	55	58	59
Power input	(4)	W	33	34	33	34	33	34	95	81

AREO C			23	23	24	24	32	33	34	42
Power supply		V-ph-Hz	230 - 1 - 50							
no. of poles			4	6	4	6	4	4	4	4
Air flow rate max cooling		m ³ /h	1411	1411	1373	1373	2485	2292	2237	3738
Heating capacity	(1)	kW	17,3	17,3	19,1	19,1	22,9	25,4	29,1	35,1
Water flow	(1)	l/h	1527	1527	1686	1686	2024	2242	2569	3098
Water pressure drop	(1)	kPa	15	15	5	5	5	5	8	7
Total cooling capacity	(2)	kW	5,00	5,00	5,23	5,23	5,72	7,22	9,65	9,72
Sensible cooling capacity	(2)	kW	3,91	3,91	4,20	4,20	5,23	6,12	7,50	7,85
Water flow	(2)	l/h	860	860	898	898	982	1239	1656	1668
Water pressure drop	(2)	kPa	7	7	2	2	1	1	4	2
Sound power level	(3)	dB(A)	63	60	59	60	63	63	64	62
Power input	(4)	W	95	81	95	81	153	153	153	400

AREO C			43	44	53	54	63	64
Power supply		V-ph-Hz	230 - 1 - 50					
no. of poles			4	4	6	6	6	6
Air flow rate max cooling		m ³ /h	3467	3359	3001	2832	4232	4125
Heating capacity	(1)	kW	39,2	43,9	38,6	42,4	48,0	64,7
Water flow	(1)	l/h	3460	3875	3406	3743	4240	5715
Water pressure drop	(1)	kPa	7	3	11	11	8	8
Total cooling capacity	(2)	kW	12,4	13,1	10,5	14,8	18,9	22,4
Sensible cooling capacity	(2)	kW	8,69	10,3	8,50	11,4	14,3	16,8
Water flow	(2)	l/h	2123	2255	1800	2022	3237	3853
Water pressure drop	(2)	kPa	3	1	5	6	4	4
Sound power level	(3)	dB(A)	61	62	53	55	56	58
Power input	(4)	W	400	400	272	272	335	335

(1) Water temperature 85°C / 75°C, air temperature 15°C - max speed available in cooling mode

(2) Water temperature 7°C / 12°C, air temperature dry bulb 27°C, wet bulb 19°C (47% relative humidity) - max speed available in cooling mode

(3) Sound power measured according to standards ISO 3741 - max speed available in cooling mode

(4) Referred to max speed available in cooling mode

All data reported in the table above refer to maximum allowed ventilation speed in order to avoid the drag of the condensation drops generated in the heat exchanger.

RATED TECHNICAL DATA AREO H - HEATING MODE

AREO H			13	13	23	23	33	33	33	43
Power supply		V-ph-Hz	230 - 1 - 50	230 - 1 - 50	230 - 1 - 50	230 - 1 - 50	230 - 1 - 50	400 - 3 - 500	400 - 3 - 500	230 - 1 - 50
no. of poles			4	6	4	6	4	4	6	4
Motor connections			Mono	Mono	Mono	Mono	Mono	Delta	Star	Mono
Rated air flow		m ³ /h	1083	855	2499	1758	3943	3800	2755	6080
Heating capacity	(1)	kW	10,2	8,89	21,3	17,3	33,2	32,5	26,9	50,4
Water flow	(1)	l/h	905	785	1882	1529	2935	2871	2376	4454
Water pressure drop	(1)	kPa	13	10	19	13	12	11	8	25
Sound power level	(2)	dB(A)	64	59	76	65	74	76	69	75
Power input		W	69	50	210	114	340	330	180	635

(1) Water temperature 85°C / 75°C, air temperature 15°C - 100% of the max speed

(2) Sound power measured according to standards ISO 3741 - 100% of the max speed

AREO H			43	43	53	53	53	63	63	63
Power supply		V-ph-Hz	400 - 3 - 500	400 - 3 - 500	230 - 1 - 50	400 - 3 - 500	400 - 3 - 500	230 - 1 - 50	400 - 3 - 500	400 - 3 - 500
no. of poles			4	6	6	4	6	6	6	8
Motor connections			Delta	Star	Mono	Delta	Star	Mono	Delta	Star
Rated air flow		m ³ /h	6223	5035	5890	7505	6128	8100	7885	6175
Heating capacity	(1)	kW	51,1	45,2	56,2	64,8	57,5	99,7	80,5	69,2
Water flow	(1)	l/h	4512	3991	4960	5720	5079	8802	7106	6112
Water pressure drop	(1)	kPa	25	20	16	20	16	29	19	15
Sound power level	(2)	dB(A)	77	70	69	76	72	70	71	66
Power input		W	690	465	375	732	775	560	575	380

(1) Water temperature 85°C / 75°C, air temperature 15°C - 100% of the max speed

(2) Sound power measured according to standards ISO 3741 - 100% of the max speed

DIMENSIONAL DRAWINGS

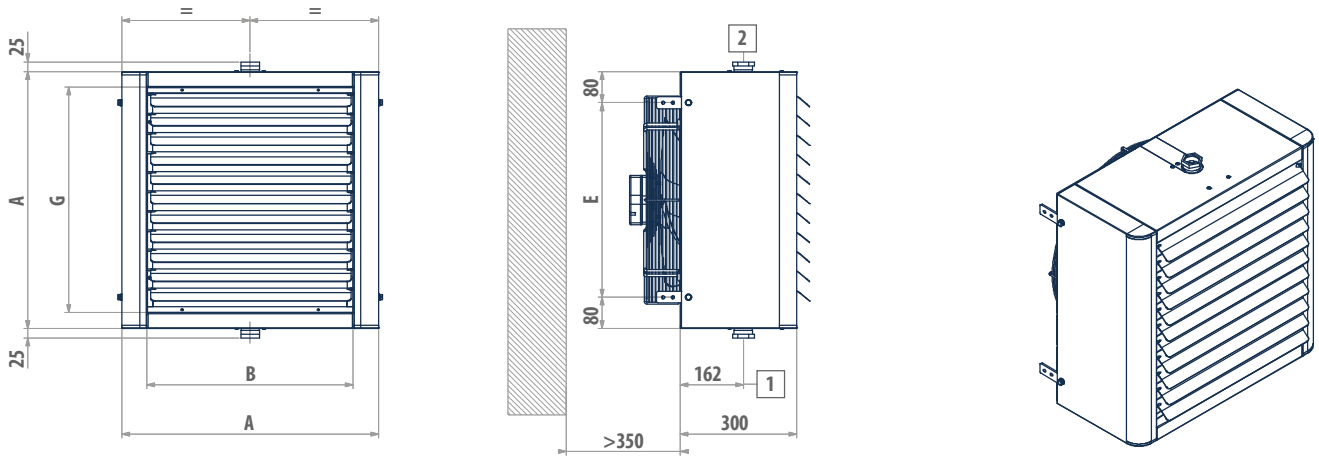
AREO H

LEGEND

- | | |
|---|------------------------------------|
| 1 | Water inlet connection female gas |
| 2 | Water outlet connection female gas |

AREO H	A mm	B mm	E mm	G mm	1 "	2 "	⚖ kg
13	460	330	300	380	1 1/4	1 1/4	20
23	560	430	400	480	1 1/4	1 1/4	26
33	660	530	500	580	1 1/4	1 1/4	35
43	760	630	600	680	1 1/4	1 1/4	41
53	860	730	700	780	1 1/4	1 1/4	52
63	960	830	800	880	1 1/4	1 1/4	61

DIMENSIONAL DRAWINGS

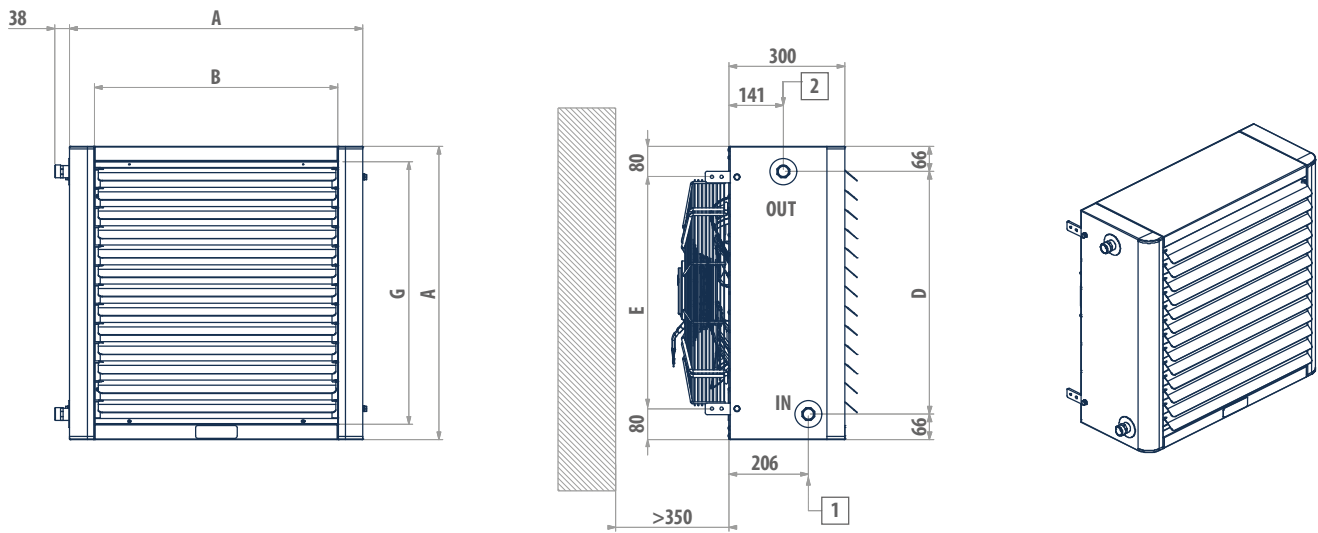
AREO P - AREO L



LEGEND

- | | |
|---|----------------------------------|
| 1 | Water inlet connection male gas |
| 2 | Water outlet connection male gas |

AREO P	A	B	D	E	G	1	2	kg
	mm	mm	mm	mm	mm	"	"	
12	460	330	328	300	380	3/4	3/4	20-20-21
13 - 14	460	330	329	300	380	3/4	3/4	20-20-21
22 - 23 - 24	560	430	428	400	480	3/4	3/4	26-26-27
32 - 33 - 34	660	530	528	500	580	1	1	34-35-37
42 - 43 - 44	760	630	628	600	680	1	1	40-41-44
53 - 54	860	730	728	700	780	1 1/4	1 1/4	52-55
63 - 64	960	830	828	800	880	1 1/4	1 1/4	61-64

AREO L	A	B	D	E	G	1	2	kg
	mm	mm	mm	mm	mm	"	"	
32 - 33	660	530	528	500	580	1	1	34-35
42 - 43	760	630	628	600	680	1	1	40-41
53	860	730	728	700	780	1 1/4	1 1/4	52
63	960	830	828	800	880	1 1/4	1 1/4	61

DIMENSIONAL DRAWINGS

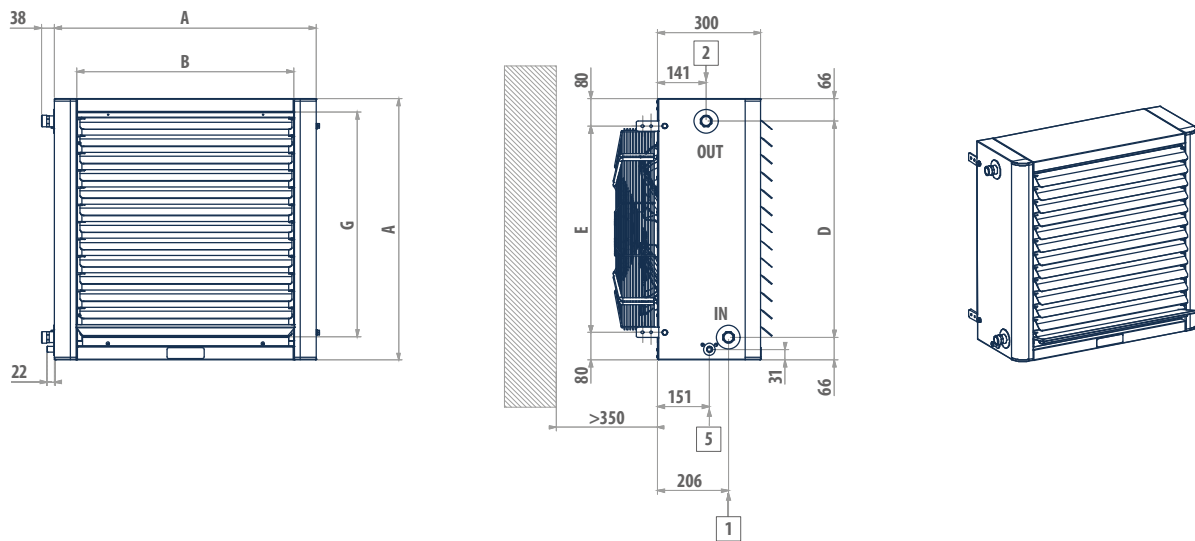
AREO C

LEGEND

- | | |
|---|----------------------------------|
| 1 | Water inlet connection male gas |
| 2 | Water outlet connection male gas |
| 5 | Condensate drainage ø 17 mm |

AREO C	A mm	B mm	D mm	E mm	G mm	1 "	2 "	kg
12 - 13 - 14	460	330	328	300	380	3/4	3/4	20-20-21
22 - 23 - 24	560	430	428	400	480	3/4	3/4	26-26-27
32 - 33 - 34	660	530	528	500	580	1	1	34-35-37
42 - 43 - 44	760	630	628	600	680	1	1	40-41-44
53 - 54	860	730	728	700	780	1 1/4	1 1/4	52-55
63 - 64	960	830	828	800	880	1 1/4	1 1/4	61-64