

Design fan coil unit with centrifugal fan and EC motor

FLAT i 2 - 5 kW



JONIX pure living **Inverter Technology**

Technology and design in a single solution

The Galletti FLAT i indoor hydronic units are equipped with a permanent magnet (brushless) electric motor, controlled by an inverter, which enables continuous adjustment in the number of fan revolutions.

In addition to the important reduction in electricity consumption compared to AC motors, the use of inverter EC technology makes it possible to continually adjust the operation of the unit to the actual thermo-hygrometric load of the interior, with a clear benefit in terms of comfort and reducing noise.

Its use is particularly effective in the frequent cases of operation under partial load conditions, the situation that occurs most frequently, when the adjustment logic allows greatly reduced motor rotation speeds with exceptional reductions in electricity consumption and noise emissions.

The operation of the unit with brushless motor is managed by EVO, MYCOMFORT LARGE or TED microprocessor control panel, using an analogue output (0-10 V) which is connected to the inverter.

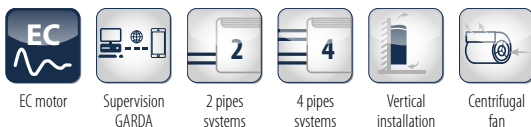

PLUS

- » Inverter-controlled EC motor
- » Low energy consumption
- » Modulating operation
- » ABS centrifugal fans
- » Can be integrated into GARDA
- » Cabinet with a refined design in UV-stabilized ABS
- » Microswitch on exit air flap
- » Reversible water connections
- » Incorporable JONIX sanitizing module



AVAILABLE VERSIONS



FLAT Li

Suspended wall installation, with cabinet, with vertical air flow.

MAIN COMPONENTS

Cabinet with a refined design

RAL9010 colour, front panel made of sheet steel. Side panels and an upper grille with covers on either side manufactured from UV-stabilised ABS to maintain the colour intact over time. The upper grille consists of a flap and adjustable louvers. The flap features a microswitch that automatically shuts down the unit when the flap itself is closed.



Structure

Built from galvanised steel sheet of extra thickness, heat and sound insulated by means of Class 1 self-extinguishing panels.

Heat exchanger

High efficiency heat exchanger made with copper piping and aluminium fins, provided with brass manifolds and vent valve. The water connections are reversible at the time of installation. On request it is possible to mount an additional heat exchanger for 4-pipe systems.

Fans

Double suction centrifugal fans, statically and dynamically balanced, manufactured from anti-static ABS, with blades having an airfoil section and offset modules. The fans are housed in a low-noise ABS volute with high-efficiency profile.

EC electric motor

The unit is equipped with an inverter board to control the motor, which can be used separately or installed on the motor itself. This system makes it possible to precisely set the maximum rotation speed of the motor (control signal 0-10 V) even when the maximum rotation speed must be controlled to reduce noise levels.



Air filter

Honey-comb polypropylene washable air filter, easily removable for maintenance operations.

ACCESSORIES

Electronic microprocessor control panels with display

DIST	MY COMFORT controller spacer for wall mounting
EVO-2-TOUCH	2.8" touch screen user interface for EVO control
EVOBOARD	Circuit board for EVO control
EVO DISP	User interface with display for EVO controller
EYNAVEL	Device for Wi-Fi or Bluetooth communication between EVOBOARD and smartphone
KBFLAE	MY COMFORT on-board installation KIT for FLAT
MCLE	Microprocessor control with display MY COMFORT LARGE
MCSUE	Humidity sensor for MY COMFORT (medium e large), EVO
MCSWE	Water sensor for MYCOMFORT and EVO controllers

Electronic microprocessor control panels

KB F	On-board FLAT/FLAT S installation kit suitable for TED controller
TED 10	Electronic controller for EC fan equipped with inverter and ON/OFF valves 230 V
TED SWA	Water temperature sensor for TED controls

Additional heat exchanger for 4-pipe systems

DF	1-row additional coil for 4 pipes system
Auxiliary water drip trays, insulating shell, condensate drainage pump	
BH	Auxiliary water drip tray for horizontal installation fan coil units

BV	Auxiliary water drip tray for vertical installation fan coil units
GIVKL	Insulating shell for VKS valve, water connections on the left
GIVKR	Insulating shell for VKS valve, water connections on the right

Base and enclosure elements

ZL	Pair of base and enclosure elements for FLAT L
-----------	--

Rear covering panels

PH	Rear painted panel for horizontal installation with cabinet
PV	Rear painted panel for vertical installation with cabinet

Valves

V2VDF+STD	2-way valves, ON/OFF or MODULATING actuator, 230 V or 24 V power supply, hydraulic kit, for main and additional heat exchanger
V2VSTD	2-way valve, ON/OFF or MODULATING actuator, 230 V or 24 V power supply, hydraulic kit, for main heat exchanger
V3VDF	3-way valves, ON/OFF or MODULATING actuator, 230 V or 24 V power supply, hydraulic kit, for additional heat exchanger
V3VSTD	2-way valves, ON/OFF or MODULATING actuator, 230 V or 24 V power supply, hydraulic kit, for main heat exchanger

Sanitisation system

JONIX inside	Sanitizing module JONIX for on-board installation
---------------------	---

2 PIPES - RATED TECHNICAL DATA

FLAT i			20			40			70		
Speed			min	med	max	min	med	max	min	med	max
Control voltage	(E)	V	5,10	6,90	8,80	4,40	6,50	8,30	4,50	6,30	8,90
Total cooling capacity	(1)(E)	kW	1,39	1,74	2,26	1,46	2,00	2,50	2,56	3,34	4,43
Sensible cooling capacity	(1)(E)	kW	1,03	1,30	1,70	1,12	1,55	1,93	2,07	2,73	3,65
FCEER class	(E)		B								
Water flow	(2)	l/h	239	300	389	251	344	430	441	575	763
Water pressure drop	(2)(E)	kPa	6	8	13	4	6	10	4	6	11
Heating capacity	(3)(E)	kW	1,52	1,84	2,39	1,76	2,32	2,89	2,96	3,76	4,96
FCCOP class	(E)		B								
Water flow	(3)	l/h	262	317	412	303	400	498	510	647	854
Water pressure drop	(3)(E)	kPa	6	8	12	3	5	8	4	7	11
Rated air flow		m ³ /h	216	284	378	283	407	520	482	659	911
Power input	(E)	W	7	11	22	9	15	31	13	21	49
Total sound power level	(4)(E)	dB(A)	38	44	53	33	42	48	43	51	58

(1) Water temperature 7°C / 12°C, air temperature dry bulb 27°C, wet bulb 19°C (47% relative humidity) according to EN1397:2015

(2) Water temperature 7°C / 12°C, air temperature dry bulb 27°C, wet bulb 19°C (47% relative humidity)

(3) Water temperature 45°C / 40°C, air temperature 20°C

(4) Sound power measured according to standards ISO 3741 and ISO 3742

(E) EUROVENT certified data

Power supply 230-1-50 (V-ph-Hz)

4 PIPES - RATED TECHNICAL DATA

FLAT i			20			40			70		
Speed			min	med	max	min	med	max	min	med	max
Control voltage	(E)	V	5,10	6,90	8,80	4,40	6,50	8,30	4,50	6,30	8,90
Total cooling capacity	(1)(E)	kW	1,39	1,74	2,26	1,46	2,00	2,50	2,56	3,34	4,43
Sensible cooling capacity	(1)(E)	kW	1,03	1,30	1,70	1,12	1,55	1,93	2,07	2,73	3,65
FCEER class	(E)		C			A			B		
Water flow	(2)	l/h	208	260	324	281	387	472	424	554	713
Water pressure drop	(2)(E)	kPa	5	8	12	3	6	9	4	6	9
Heating capacity	(3)(E)	kW	1,44	1,65	1,96	1,96	2,35	2,74	2,98	3,46	4,16
FCCOP class	(E)		C			B			B		
Water flow	(3)	l/h	124	142	169	169	202	236	257	298	358
Water pressure drop	(3)(E)	kPa	3	4	6	7	10	13	3	3	5
Rated air flow		m ³ /h	205	270	359	273	393	502	462	631	873
Power input	(E)	W	10	16	31	7	12	24	13	21	49
Total sound power level	(4)(E)	dB(A)	40	45	50	35	43	49	43	51	58

(1) Water temperature 7°C / 12°C, air temperature dry bulb 27°C, wet bulb 19°C (47% relative humidity) according to EN1397:2015

(2) Water temperature 7°C / 12°C, air temperature dry bulb 27°C, wet bulb 19°C (47% relative humidity)

(3) Water temperature 65°C / 55°C, air temperature 20°C

(4) Sound power measured according to standards ISO 3741 and ISO 3742

(E) EUROVENT certified data

Power supply 230-1-50 (V-ph-Hz)

DIMENSIONAL DRAWINGS

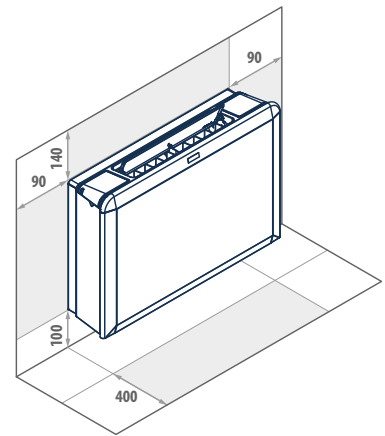
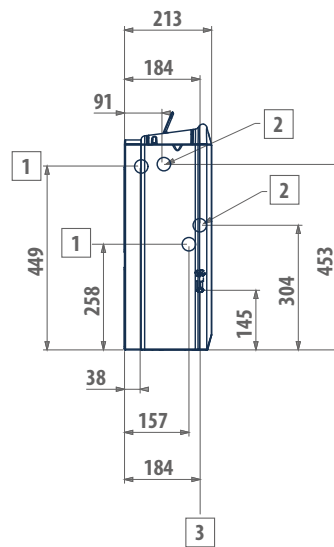
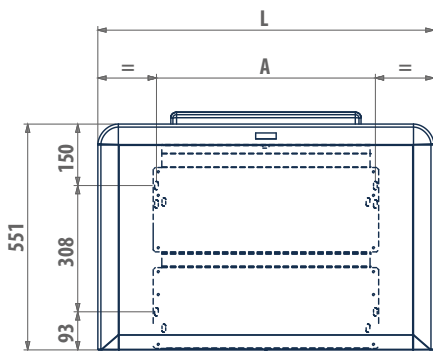
FLAT Li

LEGEND

- | | |
|---------------|---|
| 1 | Water connections standard heat exchanger \varnothing 1/2" |
| 2 | DF 1-row additional heat exchanger water connections \varnothing 1/2" |
| 3 | Condensate discharge diameter for vertical installation \varnothing 16 mm |
| \varnothing | Condensate discharge diameter for horizontal installation \varnothing 17 mm |

FLAT Li	A mm	L mm	 kg
20	534	820	19
40	704	990	23
70	874	1160	28