

Fan coil units with centrifugal fan

ESTRO 1 - 11 kW



JONIX
pure living



Supervision GARDA



2 pipes systems



4 pipes systems



Vertical installation



Centrifugal fan

The most complete range of fan coil units on the market featuring the Galletti technology, quality level and reliability.

The ESTRO series is undoubtedly the line of fan coil units with the most complete range of models and accessories that are able to meet the needs of professionals in the field.

The range consists of 20 models in 9 versions.

For the ESTRO project we selected top quality materials which, together with the great care and attention dedicated to the assembly of the main constructive components, make the ESTRO fan coil units highly reliable from a performance standpoint while minimising noise levels.

The conception underlying the ESTRO series construction makes it possible to combine models for vertical and horizontal installation: models for surface mounting on walls, floors/ceilings and recess mounting in walls/ceilings plus low body model for floor installation.

In its recess-mounted ductable version, ESTRO has a number of accessories that permit quick and economical installation with flexible ducts directly coupled with air diffusion grilles.

ESTRO can be combined with a range of on-board or wall-mounted control panels consisting of 20 options, depending on the level of comfort and adjustment required.

An innovative air ionization system ensures the sanitization of the indoor unit and the deodorization of the ambient air.

PLUS

- » 3 - 6 speed motor
- » ABS centrifugal fans
- » Can be integrated into GARDA supervision system
- » Heat exchanger up to 4 rows
- » Reversible water connections
- » Steel cabinet / ABS
- » Incorporable JONIX sanitizing module



AVAILABLE VERSIONS



ESTRO FL

Version with cabinet, suitable for wall mounting. Vertical air flow, filter on the air intake securely attached to the cabinet with quarter-turn screws.

ESTRO FL is available in 20 models.



ESTRO FA

Wall mounted with cabinet. The inclined front air flow makes the ESTRO FA version especially suited for installation in recesses up to a depth of 150 mm.

ESTRO FA is available in 19 models.



ESTRO CL

Wall mounted with cabinet, vertical air flow. Designed with a range of pastel shades, it combines well with traditional furnishings and all architectures in which the warm colours and elegant shapes make ESTRO CL a perfect interior design accessory. Steel sheet panel colour: RAL 9001. ABS parts colour: PANTONE "warm gray 2 U"

ESTRO CL is available in 20 models.



ESTRO FU

Version with cabinet, suitable for floor and ceiling mounting. The cabinet has air outlet grilles and air intake grilles with built-in filter.

ESTRO FU is available in 20 models.



ESTRO FP

Version with cabinet, suitable for ceiling mounting. The air intake is located behind the air outlet grilles. This version is especially suitable if combining with external air intake louvers.

ESTRO FP is available in 20 models.



ESTRO FB

Low-cabinet version, suitable for floor and ceiling mounting. The cabinet has air outlet grilles and air intake grilles with built-in filter. Rearranging the internal components has made it possible to reduce its height to just 438 mm.

ESTRO FB is available in 9 models.



ESTRO FC

Model for vertical and horizontal recess mounting, air intake in line with the outlet, thermally insulated galvanised sheet steel body. Plenum and connectors complete the air intake and the air flow into the room.

ESTRO FC is available in 20 models.



ESTRO FF

Model for vertical and horizontal recess mounting, front air intake, thermally insulated galvanised sheet steel body. The front air intake allows horizontal or floor recessed installation with direct intake from the false-ceiling.

ESTRO FF is available in 20 models.



ESTRO FBC

Low-cabinet version for vertical and horizontal recess mounting, front air intake with air filter, thermally insulated galvanised sheet steel body. Rearranging the strategic components has made it possible to reduce its height to just 412 mm.

ESTRO FBC is available in 9 models.

Hydraulic indoor units ESTRO

MAIN COMPONENTS

Cabinet

Composed of a painted steel sheet panel, side panels, air outlet grille (swinging by 180°) and back suction grille built from ABS. Round shapes and colours that can satisfy all interior decorating needs, in line with architectural requirements.



Structure

Built from galvanised steel sheet of extra thickness, heat and sound insulated by means of Class 1 self-extinguishing panels. FU, FB, FC, FF and FBC versions have a double drip tray for collecting condensate.

Heat exchanger

High efficiency heat exchanger made with copper piping and aluminium fins, provided with brass manifolds and vent valve. The water connections are reversible at the time of installation. On request it is possible to mount an additional heat exchanger for 4-pipe systems.

Electric motor

It is mounted on vibration dampers, with permanently activated capacitor and thermal protection of the windings, and is directly coupled with the fans. It is available as either a 3- or 6-speed version in order to meet all the specific needs of performance, quietness, and power consumption.

Fans

Double suction centrifugal fans, statically and dynamically balanced, manufactured from anti-static ABS, with blades having an airfoil section and offset modules. The fans are housed in a low-noise ABS volute with high-efficiency profile.



Air filter

Honey-comb polypropylene washable air filter, easily removable for maintenance operations. On FU version the air filters are fitted onto the air inlet grille.

CONFIGURATOR

The models are completely configurable by selecting the version and the options. To the right is shown an example of configuration.

Version	Field	1	2	3	4	5	6	7	8	9	10	11
EF03		L	0	M	0	1	E	0	0	0	0	A

EF Product type ESTRO; 03 Size
To verify the compatibility of the options, use the selection software or the price list.

CONFIGURATOR

- | | |
|--|--|
| <p>1 Version</p> <ul style="list-style-type: none"> A A - Wall mounted with cabinet B B - Wall installation with low-body cabinet C C - Recessed installation F F - Recessed installation G BC - Low-body recessed installation L L - Wall mounted with cabinet O CLASSIC - Wall installation with cabinet P P - Ceiling installation with cabinet U U - Wall and ceiling installation with cabinet <p>2 Motor</p> <ul style="list-style-type: none"> 0 3-speed motor G Electric fan with GreenTech BLDC motor I BLDC motor P 6 speed motor <p>3 Main coil hydraulic side</p> <ul style="list-style-type: none"> L Water connections on the left side M Water connections on the left side - 4 rows R Water connections on the right S Water connections on the right side - 4 rows <p>4 Additional coil hydraulic side / heating element</p> <ul style="list-style-type: none"> 0 Absent E RE - Electrical heating elements L Water connections on the left side R Water connections on the right <p>5 Valve</p> <ul style="list-style-type: none"> 0 Absent 1 VKS - 3 ways valve - 230 V - ON/OFF - complete hydraulic kit 2 KV - 2 ways valve - 230 V - ON/OFF 3 VKMS - 3 ways valve - 24 V - MODULATING - complete hydraulic kit 4 KVM - 2 ways valve - 24 V - MODULATING 5 VKS24 - 3 way valve - 24 V - ON/OFF - complete hydraulic kit 6 KV24 - 2 way valve - 24 V - ON/OFF A VKSND - 3 way valve - 230 V - ON/OFF - hydraulic kit on coil side B VKMSND - 3 ways valve - 24 V - MODULATING - hydraulic kit on coil side C VKS24ND - 3 ways valve - 24 V - ON/OFF - hydraulic kit on coil side H VPIK - 2-way valve - pressure independent - 230 V - ON/OFF I VPIKM - 2-way valve - pressure independent - 24 V - MODULATING | <p>6 Control panel</p> <ul style="list-style-type: none"> 0 Absent 1 CB - On-board speed selector 2 TB - Speed selector and thermostat 3 TIB - Speed selector, thermostat and S/W selecting switch 4 TED 2T - microprocessor control for 2 pipes 5 TED 4T - microprocessor control for 4 pipes 6 TED 10 - microprocessor control for BLDC A MCBE - My comfort base B MCME - My comfort medium C MCLE - My comfort large D LED 503 E EVOBOARD - Circuit board F EVO BOARD+EVO DISP - (Circuit board + display) G EVOBOARD circuit board + NAVEL Wi-Fi module <p>7 Probes</p> <ul style="list-style-type: none"> 0 Absent 1 SA - Remote air probe for MYCOMFORT, LED503 and EVO 2 SW - Water probe for MYCOMFORT, LED503 and EVO 3 SU - Humidity probe for MYCOMFORT and EVO 4 SA+SW - Remote air and water probes for MYCOMFORT, LED503 and EVO 5 SA+SU - Remote air and humidity probes for MYCOMFORT and EVO 6 SA+SU+SW - Remote air, water, humidity probes for MYCOMFORT and EVO A TC - Thermostat for minimum water temperature B SA - Remote air probe for TED C SW - Water probe for TED D SA + SW - Air and water probes for TED <p>8 Accessories</p> <ul style="list-style-type: none"> 0 Absent 2 JONIX 4 BV - Auxiliary drip tray 5 BH - Auxiliary drip tray 6 GIVK - Insulating shell <p>9 Filter</p> <ul style="list-style-type: none"> 0 Standard filter air <p>10 Release</p> <ul style="list-style-type: none"> 0 0 A A |
|--|--|

CONTROL PANELS

Electromechanical control panels

CB	On-board speed switch
CD	Recess wall-mounted speed switch
TB	On-board speed thermostat and switch
TC	Thermostat for minimum water temperature in heating mode (42 °C)

Electronic microprocessor control panels with display

DIST	MY COMFORT controller spacer for wall mounting
E2TK	Touch screen 2.8" user panel for EVO control EVO-2-TOUCH, frame in aluminium color black RAL9005
E2TY	Touch screen 2.8" user panel for EVO control EVO-2-TOUCH, frame in natural brushed aluminium
EVOBOARD	Circuit board for EVO control
EVODISP	User interface with display for EVO controller
EYNAVEL	Device for Wi-Fi or Bluetooth communication between EVOBOARD and smartphone
KBESTE	MY COMFORT on-board installation kit for ESTRO

KL	LED503 on-board controller installation kit for ESTRO
LED503	Recessed wall-mounted electronic display controller LED 503
MCBE	MYCOMFORT BASE electronic controller with display
MCLE	Microprocessor control with display MY COMFORT LARGE
MCME	MYCOMFORT MEDIUM electronic controller with display
MCSUE	Humidity sensor for MY COMFORT (medium e large), EVO
MCSWE	Water sensor for MYCOMFORT and EVO controllers

Electronic microprocessor control panels

KB A	On-board ESTRO FA installation kit suitable for TED controller
KB L DX	On-board ESTRO FL/FU/FB installation kit on the right side suitable for TED controller
KB L SX	On-board ESTRO FL/FU/FB installation kit on the left side suitable for TED controller
TED 2T	Electronic controller for AC fan control and one ON/OFF 230 V valve
TED 4T	Electronic controller for AC fan control and two ON/OFF 230 V valves
TED SWA	Water temperature sensor for TED controls

ACCESSORIES

Power interface and regulating louver controllers

CSB	On-board controller for opening and closing the motor-driven regulating louver
CSD	Recess mounted controller for opening and closing the SM motor-driven regulating louver
KP	Power interface for connecting in parallel up to 4 fan coil units to the one controller

Additional heat exchanger for 4-pipe systems

DF	1-row additional heat exchanger for 4-pipe systems (not suitable for ESTRO "M" models)
-----------	--

Auxiliary water drip trays, insulating shell, condensate drainage pump

BH	Auxiliary water drip tray for horizontal installation fan coil units
BV	Auxiliary water drip tray for vertical installation fan coil units
GIVKL	Insulating shell for VKS valve, water connections on the left
GIVKR	Insulating shell for VKS valve, water connections on the right
KSC	Condensate drainage pump kit

Base and enclosure elements

D	Support elements for ESTRO FC
ZA	Pair of support covering elements with front grille for ESTRO FA
ZAG	Pair of support covering elements for ESTRO FA
ZC	Pair of support covering elements for ESTRO CL
ZCG	Pair of support covering elements for ESTRO CL
ZL	Pair of support covering elements for ESTRO FL
ZLG	Pair of support covering elements with front grille for ESTRO FL

Rear covering panels

PH	Rear painted panel for horizontal installation with cabinet
PV	Rear painted panel for vertical installation with cabinet

Electrical heating elements

RE	Heating element with installation kit, relay box and safety devices
-----------	---

Air inlet and outlet grilles

GE	Aluminium external air intake grille with subframe
GEF	Aluminium external air intake grille with subframe and air filter
GM	Aluminium air outlet grille with 2-row fins and subframe
RGC	Plenum with circular collars for air outlet grille

Plenum and connectors

RA90	Angular inlet connector
RAD	Straight inlet connector
RADC	Air inlet plenum with circular collars
RM90	Angular outlet connector
RM90C	Angular outlet insulated connector
RMCD	Straight outlet insulated connector
RMCD C	Air outlet plenum with circular collars
RMD	Straight outlet connector

External air intake louvers

S	Manual external air intake louver
----------	-----------------------------------

SM	Motor-driven louver, with motor on the right with transformer
SM	Motor-driven louver, with motor on the left with transformer
SMC	Motor driven louver, with motor on the right, with transformer
SMC	Motor driven louver, with motor on the left, with transformer

Valves

KV	2-way valve, ON/OFF actuator, hydraulic kit on water connection side for main heat exchanger
KV24	2-way valve, ON/OFF actuator, 24 V power supply, hydraulic kit on water connection side for main heat exchanger
KV24DF	2-way valve, ON/OFF actuator, 24 V power supply, hydraulic kit on water connection side for main and additional heat exchanger
KVDF	2-way valve, ON/OFF actuator, 230 V power supply, hydraulic kit on water connection side for main and additional heat exchanger
KVM	2-way valve, MODULATING actuator, 24 V power supply, hydraulic kit on water connection side for main heat exchanger
KVMDF	2-way valve, MODULATING actuator, 24 V power supply, hydraulic kit on water connection side for main and additional heat exchanger
VKDF	3-way valve, ON/OFF actuator, 230 V power supply, complete hydraulic kit for additional heat exchanger
VKDF24	3-way valve, ON/OFF actuator, 24 V power supply, complete hydraulic kit for additional heat exchanger
VKDF24ND	3-way valve, ON/OFF actuator, 24 V power supply, hydraulic kit without holder, for additional heat exchanger
VKDFND	3-way valve, ON/OFF actuator, 230 V power supply, hydraulic kit without holder, for additional heat exchanger
VKDFND	3-way valve, MODULATING actuator, 24 V power supply, complete hydraulic kit for additional heat exchanger
VKDFND	3-way valve, MODULATING actuator, 24 V power supply, hydraulic kit without holder, for additional heat exchanger
VKMS	3-way valve, MODULATING actuator, 24 V power supply, complete hydraulic kit for main heat exchanger
VKMSND	3-way valve, MODULATING actuator, 24 V power supply, hydraulic kit without holder, for main heat exchanger
VKS	3-way valve, ON/OFF actuator, 1230 V power supply, complete hydraulic kit for main heat exchanger
VKS24	3-way valve, ON/OFF actuator, 24 V power supply, complete hydraulic kit for main heat exchanger
VKS24ND	3-way valve, ON/OFF actuator, 24 V power supply, hydraulic kit without holder, for main heat exchanger
VKSND	3-way valve, ON/OFF actuator, 230 V power supply, hydraulic kit without holder, for main heat exchanger
VPIC	2-way valves pressure independent, ON/OFF or MODULATING actuator, 230 V or 24 V power supply, hydraulic kit, for main heat exchanger

Sanitisation system

JONIX - on board	Sanitizing module JONIX for on-board installation
-------------------------	---

Hydraulic indoor units ESTRO

2 PIPES - RATED TECHNICAL DATA

ESTRO			1			2			3			4		
Speed			min	med	max	min	med	max	min	med	max	min	med	max
Total cooling capacity	(1)(E)	kW	0,75	0,90	1,12	1,02	1,21	1,50	1,24	1,48	1,69	1,34	1,66	1,91
Sensible cooling capacity	(1)(E)	kW	0,57	0,68	0,84	0,77	0,94	1,16	0,93	1,10	1,25	0,98	1,20	1,37
FCEER class	(E)		E											
Water flow	(2)	l/h	129	155	193	176	208	258	214	255	291	231	286	329
Water pressure drop	(2)(E)	kPa	4	5	7	7	9	13	8	11	14	7	10	13
Heating capacity	(3)(E)	kW	0,95	1,11	1,32	1,21	1,48	1,82	1,45	1,72	1,84	1,50	1,81	2,15
FCCOP class	(E)		E											
Water flow	(3)	l/h	164	191	227	208	255	313	250	296	317	258	312	370
Water pressure drop	(3)(E)	kPa	5	6	8	8	11	15	9	12	14	6	9	12
Rated air flow		m ³ /h	127	189	231	167	233	319	210	271	344	214	271	344
Power input	(E)	W	18	21	32	21	28	37	25	36	53	24	36	53
Total sound power level	(4)(E)	dB(A)	30	32	40	37	42	47	38	44	49	40	44	50

ESTRO			4M			5			6			6M		
Speed			min	med	max	min	med	max	min	med	max	min	med	max
Total cooling capacity	(1)(E)	kW	1,48	1,81	2,19	1,57	1,99	2,36	1,73	2,34	2,87	1,90	2,60	3,23
Sensible cooling capacity	(1)(E)	kW	1,04	1,28	1,55	1,15	1,53	1,82	1,23	1,66	2,05	1,30	1,79	2,24
FCEER class	(E)		D			E			D			D		
Water flow	(2)	l/h	255	312	377	270	343	406	298	403	494	327	448	556
Water pressure drop	(2)(E)	kPa	10	14	20	8	12	16	6	9	13	7	12	17
Heating capacity	(3)(E)	kW	1,53	1,88	2,29	1,74	2,26	2,70	1,76	2,37	2,94	1,94	2,68	3,37
FCCOP class	(E)		E											
Water flow	(3)	l/h	263	324	394	300	389	465	303	408	506	334	461	580
Water pressure drop	(3)(E)	kPa	9	12	17	8	12	17	5	8	11	6	10	15
Rated air flow		m ³ /h	211	271	344	267	341	442	293	341	442	241	341	442
Power input	(E)	W	30	45	66	29	44	57	29	43	56	29	43	56
Total sound power level	(4)(E)	dB(A)	41	45	51	35	43	48	36	42	48	35	43	49

ESTRO			7			7M			8			8M		
Speed			min	med	max	min	med	max	min	med	max	min	med	max
Total cooling capacity	(1)(E)	kW	1,94	2,58	3,45	2,44	3,33	4,48	2,47	3,21	4,23	2,74	3,64	4,86
Sensible cooling capacity	(1)(E)	kW	1,41	1,99	2,69	1,69	2,31	3,12	1,76	2,39	3,05	1,90	2,53	3,40
FCEER class	(E)		E			D			D			D		
Water flow	(2)	l/h	334	444	594	420	573	771	425	553	728	472	627	837
Water pressure drop	(2)(E)	kPa	4	7	12	6	11	18	5	8	12	7	12	20
Heating capacity	(3)(E)	kW	2,39	3,13	4,05	2,51	3,40	4,57	2,47	3,24	4,24	2,80	3,70	4,95
FCCOP class	(E)		E											
Water flow	(3)	l/h	412	539	697	432	585	787	425	558	730	482	637	852
Water pressure drop	(3)(E)	kPa	5	8	13	5	9	15	4	6	10	6	10	17
Rated air flow		m ³ /h	331	450	640	320	450	640	420	497	706	361	497	706
Power input	(E)	W	40	50	65	37	61	98	38	61	98	38	61	98
Total sound power level	(4)(E)	dB(A)	35	43	52	36	44	53	35	43	53	36	44	54

(1) Water temperature 7°C / 12°C, air temperature dry bulb 27°C, wet bulb 19°C (47% relative humidity) according to EN1397:2015

(2) Water temperature 7°C / 12°C, air temperature dry bulb 27°C, wet bulb 19°C (47% relative humidity)

(3) Water temperature 45°C / 40°C, air temperature 20°C

(4) Sound power measured according to standards ISO 3741 and ISO 3742

(E) EUROVENT certified data

Power supply 230-1-50 (V-ph-Hz)

2 PIPES - RATED TECHNICAL DATA

ESTRO			9			9M			95			10		
Speed			min	med	max	min	med	max	min	med	max	min	med	max
Total cooling capacity	(1)(E)	kW	2,95	3,59	4,41	3,47	4,30	5,30	3,37	4,12	5,15	3,88	5,14	6,53
Sensible cooling capacity	(1)(E)	kW	2,27	2,85	3,55	2,42	3,00	3,72	2,29	2,93	3,72	2,75	3,70	4,73
FCEER class	(E)		D			D			D			E		
Water flow	(2)	l/h	508	618	759	598	740	913	580	709	887	668	885	1124
Water pressure drop	(2)(E)	kPa	7	10	14	11	16	24	10	14	21	5	9	12
Heating capacity	(3)(E)	kW	3,31	4,08	4,98	3,53	4,37	5,39	3,52	4,32	5,49	3,97	5,17	6,49
FCCOP class	(E)		E											
Water flow	(3)	l/h	570	703	858	608	753	928	606	744	945	684	890	1118
Water pressure drop	(3)(E)	kPa	7	10	14	10	14	20	8	12	18	4	7	10
Rated air flow		m ³ /h	527	605	785	470	605	785	601	615	814	661	771	1011
Power input	(E)	W	47	68	98	47	68	98	52	73	107	86	127	182
Total sound power level	(4)(E)	dB(A)	43	49	56	44	50	57	44	51	58	47	54	61

ESTRO			10M			11			11M			12		
Speed			min	med	max	min	med	max	min	med	max	min	med	max
Total cooling capacity	(1)(E)	kW	4,32	5,69	7,20	4,00	6,07	7,78	4,55	6,81	8,74	6,76	8,53	10,7
Sensible cooling capacity	(1)(E)	kW	2,98	3,93	4,99	2,94	4,46	5,72	3,18	4,78	6,15	4,91	6,22	7,76
FCEER class	(E)		E											
Water flow	(2)	l/h	744	980	1240	689	1045	1340	784	1173	1505	1164	1469	1841
Water pressure drop	(2)(E)	kPa	8	14	21	6	13	20	9	19	29	14	22	32
Heating capacity	(3)(E)	kW	4,28	5,56	6,96	4,39	6,53	8,37	4,75	7,02	9,00	7,45	9,29	12,2
FCCOP class	(E)		E											
Water flow	(3)	l/h	737	957	1199	756	1124	1441	818	1209	1550	1283	1600	2101
Water pressure drop	(3)(E)	kPa	7	11	16	6	12	18	8	16	25	14	20	33
Rated air flow		m ³ /h	570	771	1011	682	1022	1393	642	1022	1393	1154	1317	1850
Power input	(E)	W	86	127	182	109	169	244	109	169	244	210	240	310
Total sound power level	(4)(E)	dB(A)	48	55	62	49	60	67	50	61	68	60	64	71

- (1) Water temperature 7°C / 12°C, air temperature dry bulb 27°C, wet bulb 19°C (47% relative humidity) according to EN1397:2015
(2) Water temperature 7°C / 12°C, air temperature dry bulb 27°C, wet bulb 19°C (47% relative humidity)
(3) Water temperature 45°C / 40°C, air temperature 20°C
(4) Sound power measured according to standards ISO 3741 and ISO 3742
(E) EUROVENT certified data
Power supply 230-1-50 (V-ph-Hz)

Hydraulic indoor units ESTRO

4 PIPES - RATED TECHNICAL DATA

ESTRO			1			2			3			4		
Speed			min	med	max	min	med	max	min	med	max	min	med	max
Total cooling capacity	(1)(E)	kW	0,74	0,88	1,10	0,97	1,11	1,42	1,22	1,44	1,64	1,24	1,52	1,74
Sensible cooling capacity	(1)(E)	kW	0,56	0,67	0,83	0,73	0,87	1,10	0,91	1,07	1,22	0,96	1,18	1,41
FCEER class	(E)		E											
Water flow	(2)	l/h	127	152	189	167	191	245	210	248	282	214	262	300
Water pressure drop	(2)(E)	kPa	4	5	7	6	8	12	8	11	14	7	10	13
Heating capacity	(3)(E)	kW	1,18	1,31	1,49	1,31	1,49	1,66	1,36	1,56	1,76	1,36	1,56	1,76
FCCOP class	(E)		E											
Water flow	(3)	l/h	102	113	128	113	128	143	117	134	152	117	134	152
Water pressure drop	(3)(E)	kPa	2	3	4	3	4	4	4	5	7	4	5	6
Rated air flow		m ³ /h	146	184	226	174	225	307	205	261	330	205	261	327
Power input	(E)	W	18	21	32	21	28	37	25	36	53	24	36	53
Total sound power level	(4)(E)	dB(A)	30	32	40	33	39	45	40	44	49	38	44	50

ESTRO			5			6			7		
Speed			min	med	max	min	med	max	min	med	max
Total cooling capacity	(1)(E)	kW	1,55	1,96	2,32	1,70	2,29	2,81	1,92	2,54	3,36
Sensible cooling capacity	(1)(E)	kW	1,14	1,50	1,79	1,21	1,62	2,01	1,40	1,96	2,61
FCEER class	(E)		E			D			E		
Water flow	(2)	l/h	267	338	400	293	394	484	331	437	579
Water pressure drop	(2)(E)	kPa	8	12	16	5	8	11	4	7	12
Heating capacity	(3)(E)	kW	1,78	2,18	2,53	1,88	2,31	2,68	2,82	3,47	4,20
FCCOP class	(E)		E								
Water flow	(3)	l/h	153	188	218	162	199	231	243	299	362
Water pressure drop	(3)(E)	kPa	2	3	3	2	3	4	8	12	16
Rated air flow		m ³ /h	238	334	432	237	332	431	316	444	628
Power input	(E)	W	29	44	57	29	43	56	37	61	98
Total sound power level	(4)(E)	dB(A)	34	43	48	33	41	47	36	45	53

ESTRO			8			9			95		
Speed			min	med	max	min	med	max	min	med	max
Total cooling capacity	(1)(E)	kW	2,44	3,17	4,16	3,06	3,74	4,57	3,49	4,27	5,31
Sensible cooling capacity	(1)(E)	kW	1,74	2,36	2,99	2,23	2,80	3,47	2,38	3,01	3,78
FCEER class	(E)		D								
Water flow	(2)	l/h	420	546	716	527	644	787	601	735	914
Water pressure drop	(2)(E)	kPa	5	7	12	7	10	14	10	14	20
FCCOP class	(E)		E								
Heating capacity	(3)(E)	kW	2,73	3,22	3,82	3,55	4,07	4,64	3,70	4,20	4,84
Water flow	(3)	l/h	235	277	329	306	350	400	319	362	417
Water pressure drop	(3)(E)	kPa	8	10	14	5	6	8	7	9	12
Rated air flow		m ³ /h	356	490	690	460	593	763	478	603	792
Power input	(E)	W	38	61	98	47	68	98	52	73	107
Total sound power level	(4)(E)	dB(A)	39	46	56	48	53	58	46	52	59

ESTRO			10			11			12		
Speed			min	med	max	min	med	max	min	med	max
Total cooling capacity	(1)(E)	kW	3,84	5,10	6,46	3,96	5,99	7,64	6,70	8,44	10,5
Sensible cooling capacity	(1)(E)	kW	2,73	3,67	4,67	2,91	4,40	5,61	4,86	6,15	7,63
FCEER class	(E)		E								
Water flow	(2)	l/h	661	878	1112	682	1031	1316	1154	1453	1806
Water pressure drop	(2)(E)	kPa	5	8	12	5	10	16	14	21	30
FCCOP class	(E)		E								
Heating capacity	(3)(E)	kW	5,02	6,02	6,97	4,85	6,29	7,35	6,93	8,01	9,52
Water flow	(3)	l/h	432	518	600	418	542	633	597	690	820
Water pressure drop	(3)(E)	kPa	14	19	24	14	22	29	24	31	42
Rated air flow		m ³ /h	565	765	998	636	1007	1362	999	1300	1814
Power input	(E)	W	86	127	182	109	169	244	210	240	310
Total sound power level	(4)(E)	dB(A)	46	54	60	48	58	66	63	64	71

(1) Water temperature 7°C / 12°C, air temperature dry bulb 27°C, wet bulb 19°C (47% relative humidity) according to EN1397:2015

(2) Water temperature 7°C / 12°C, air temperature dry bulb 27°C, wet bulb 19°C (47% relative humidity)

(3) Water temperature 65°C / 55°C, air temperature 20°C

(4) Sound power measured according to standards ISO 3741 and ISO 3742

(E) EUROVENT certified data

DIMENSIONAL DRAWINGS

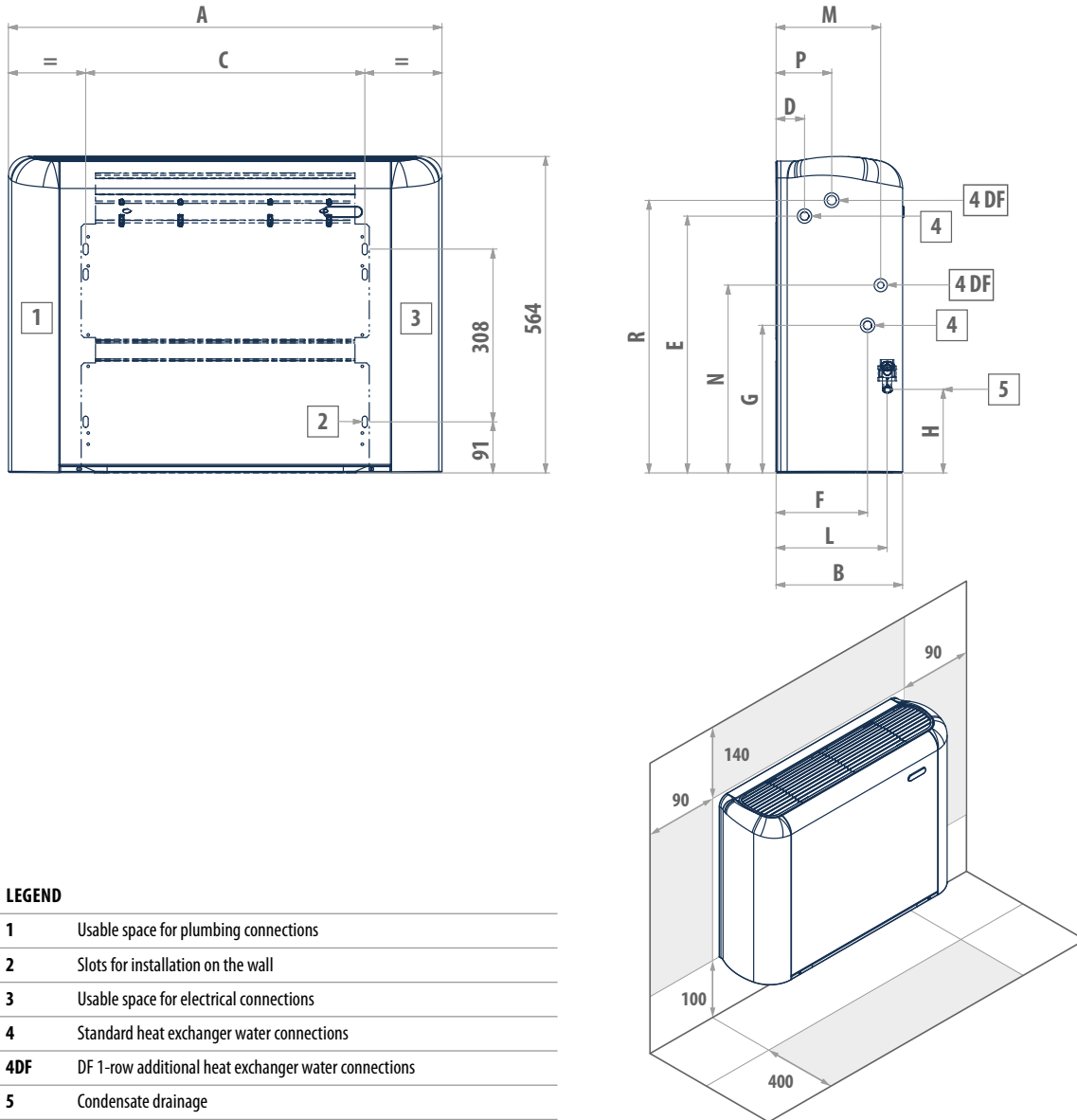
ESTRO FL - CL

LEGEND

1	Usable space for plumbing connections
2	Slots for installation on the wall
3	Usable space for electrical connections
4	Standard heat exchanger water connections
4DF	DF 1-row additional heat exchanger water connections
5	Condensate drainage

ESTRO	1	2	3	4	4M	5	6	6M	7	7M	8	8M	9	9M	95	10	10M	11	11M	12	
ON/OFF motor (3 speed)	x	x	x	x	x	x	x	x	x	x	x	x	x	x	x	x	x	x	x	x	x
ON/OFF motor (6 speed)	x	-	x	x	x	x	x	x	x	x	x	x	x	x	x	-	-	-	-	-	-
Inverter-controlled motor	x	-	x	x	x	x	x	x	x	-	x	-	x	x	x	-	-	x	x	-	-
GreenTech inverter-controlled motor	x	-	x	x	x	x	x	x	x	-	x	-	x	x	-	-	-	-	-	-	-

x = available

ESTRO	A	B	C	D	E	F	G	H	L	M	N	P	R	4	4DF	5	
	mm	mm	mm	mm	mm	mm	mm	mm	mm	mm	mm	mm	mm	"	"	mm	kg
1 - 2 - 3 - 4 - 4M	774	226	498	51	458	163	263	149	198	187	335	99	486	1/2	1/2	16	21
5 - 6 - 6M	984	226	708	51	458	163	263	149	198	187	335	99	486	1/2	1/2	16	27
7 - 7M - 8 - 8M - 9 - 9M	1194	226	918	51	458	163	263	149	198	187	335	99	486	1/2	1/2	16	33
95	1194	251	918	48	497	185	259	155	220	195	348	120	478	3/4	1/2	16	34
10 - 10M - 11 - 11M	1404	251	1128	48	497	185	259	155	220	195	348	120	478	3/4	1/2	16	43
12	1614	251	1338	48	497	185	259	155	220	195	348	120	478	3/4	1/2	16	53

DIMENSIONAL DRAWINGS

ESTRO FA

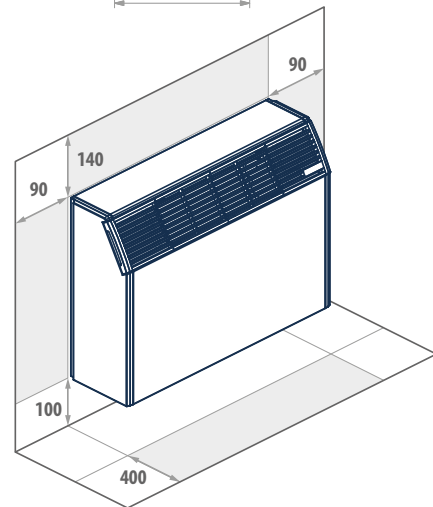
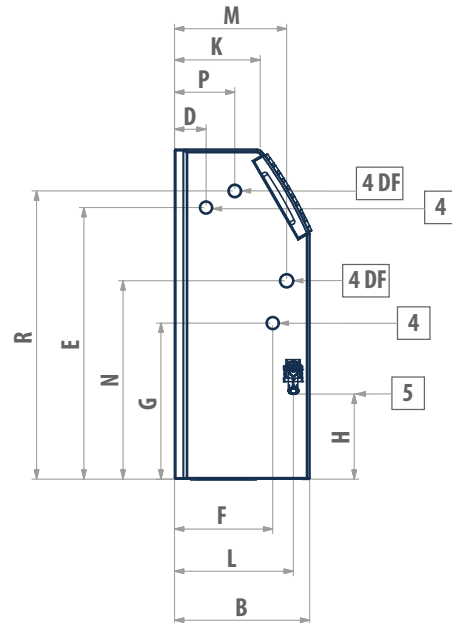
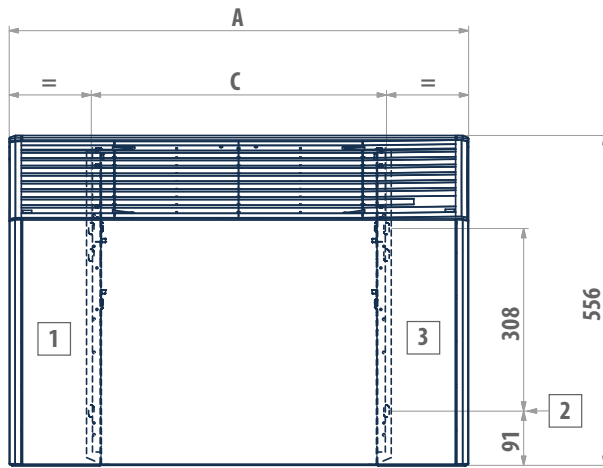

LEGEND

1	Usable space for plumbing connections
2	Slots for installation on the wall
3	Usable space for electrical connections
4	Standard heat exchanger water connections
4DF	DF 1-row DF additional heat exchanger water connections
5	Condensate drainage

ESTRO FA	1	2	3	4	4M	5	6	6M	7	7M	8	8M	9	9M	10	10M	11	11M	12	
ON/OFF motor (3 speed)	x	x	x	x	x	x	x	x	x	x	x	x	x	x	x	x	x	x	x	x
ON/OFF motor (6 speed)	x	-	x	x	x	x	x	x	x	x	x	x	x	x	-	-	-	-	-	-
Inverter-controlled motor	x	-	x	x	x	x	x	x	x	-	x	-	x	x	-	-	x	x	-	-
GreenTech inverter-controlled motor	x	-	x	x	x	x	x	x	x	-	x	-	x	x	-	-	-	-	-	-

x = available

ESTRO	A	B	C	D	E	F	G	H	K	L	M	N	P	R	4	4DF	5	kg
	mm	mm	mm	mm	mm	mm	mm	mm	mm	mm	mm	mm	mm	mm	"	"	mm	kg
1 - 2 - 3 - 4 - 4M	774	228	498	53	458	166	263	149	145	198	187	335	99	486	1/2	1/2	16	22
5 - 6 - 6M	984	228	708	53	458	166	263	149	145	198	187	335	99	486	1/2	1/2	16	26
7 - 7M - 8 - 8M - 9 - 9M	1194	228	918	53	458	166	263	149	145	198	187	335	99	486	1/2	1/2	16	32
10 - 10M - 11 - 11M	1404	253	1128	50	497	188	259	155	170	220	195	348	120	478	3/4	1/2	16	42
12	1614	253	1338	50	497	188	259	155	170	220	195	348	120	478	3/4	1/2	16	50

DIMENSIONAL DRAWINGS

ESTRO FU

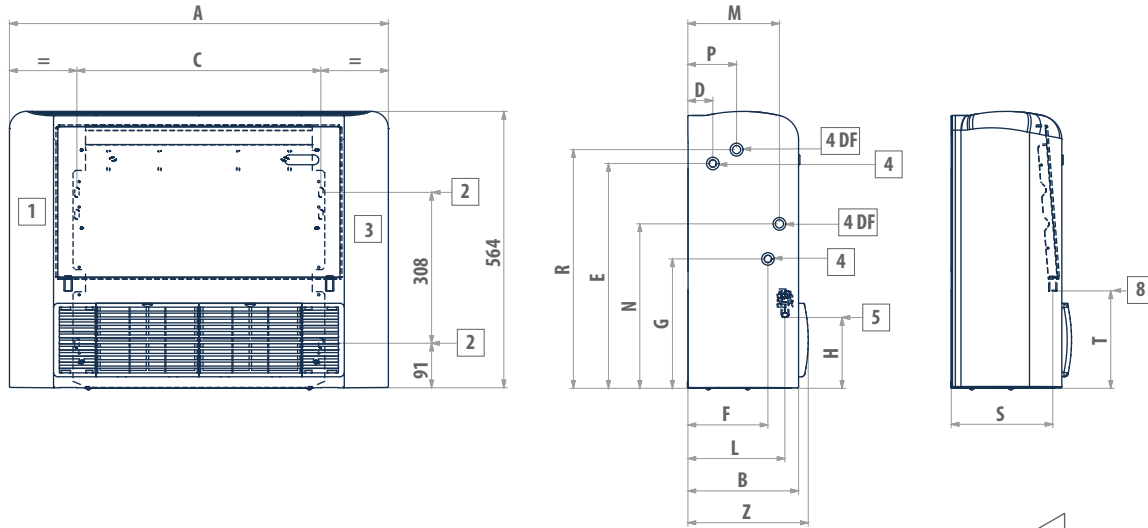

LEGEND

1	Usable space for plumbing connections
2	Slots for installation on the wall
3	Usable space for electrical connections
4	Standard heat exchanger water connections
4DF	DF 1-row DF additional heat exchanger water connections
5	Condensate drainage vertical installation
8	Condensate drainage horizontal installation

ESTRO FU	1	2	3	4	4M	5	6	6M	7	7M	8	8M	9	9M	95	10	10M	11	11M	12	
ON/OFF motor (3 speed)	x	x	x	x	x	x	x	x	x	x	x	x	x	x	x	x	x	x	x	x	x
ON/OFF motor (6 speed)	x	-	x	x	x	x	x	x	x	x	x	x	x	x	x	-	-	-	-	-	-
Inverter-controlled motor	x	-	x	x	x	x	x	x	x	-	x	-	x	x	x	-	-	x	x	-	-
GreenTech inverter-controlled motor	x	-	x	x	x	x	x	x	x	-	x	-	x	x	-	-	-	-	-	-	-

x = available

ESTRO FU	A	B	C	D	E	F	G	H	L	M	N	P	R	S	T	Z	4	kg
	mm	mm	mm	mm	mm	mm	mm	mm	mm	mm	mm	mm	mm	mm	mm	mm	"	
1 - 2 - 3 - 4 - 4M	774	226	498	51	458	163	263	149	198	187	335	99	486	208	198	246	1/2	22
5 - 6 - 6M	984	226	708	51	458	163	263	149	198	187	335	99	486	208	198	246	1/2	29
7 - 7M - 8 - 8M - 9 - 9M	1194	226	918	51	458	163	263	149	198	187	335	99	486	208	198	246	1/2	35
95	1194	251	918	48	497	185	259	155	220	195	348	120	478	234	208	271	3/4	36
10 - 10M - 11 - 11M	1404	251	1128	48	497	185	259	155	220	195	348	120	478	234	208	271	3/4	45
12	1614	251	1338	48	497	185	259	155	220	195	348	120	478	234	208	271	3/4	55

DIMENSIONAL DRAWINGS

ESTRO FP

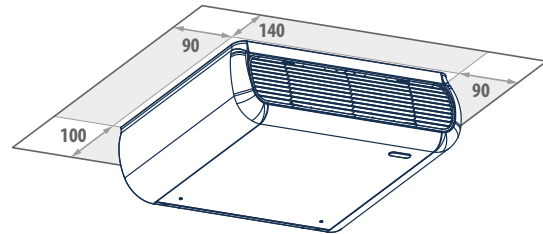
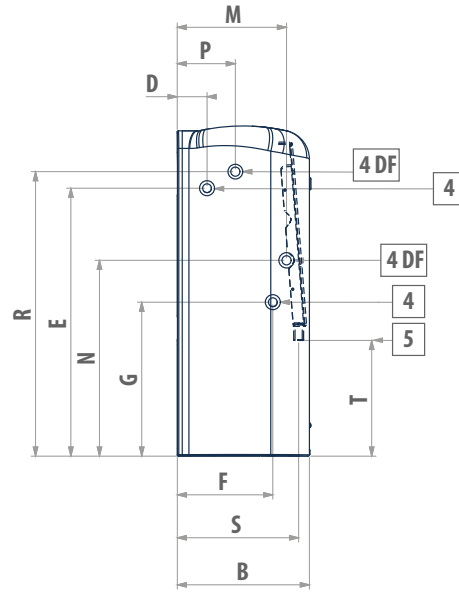
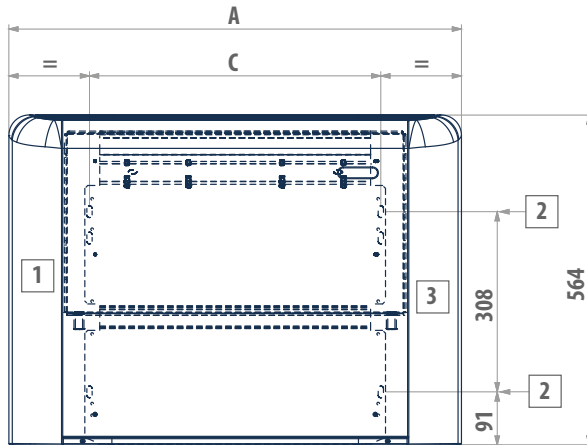

LEGEND

1	Usable space for plumbing connections
2	Slots for installation on the wall
3	Usable space for electrical connections
4	Standard heat exchanger water connections
4DF	DF 1-row DF additional heat exchanger water connections
5	Condensate drainage

ESTRO FP	1	2	3	4	4M	5	6	6M	7	7M	8	8M	9	9M	95	10	10M	11	11M	12	
ON/OFF motor (3 speed)	x	x	x	x	x	x	x	x	x	x	x	x	x	x	x	x	x	x	x	x	x
ON/OFF motor (6 speed)	x	-	x	x	x	x	x	x	x	x	x	x	x	x	x	-	-	-	-	-	-
Inverter-controlled motor	x	-	x	x	x	x	x	x	x	-	x	-	x	x	x	-	-	x	x	-	
GreenTech inverter-controlled motor	x	-	x	x	x	x	x	x	x	-	x	-	x	x	-	-	-	-	-	-	

x = available

ESTRO	A	B	C	D	E	F	G	M	N	P	R	S	T	4	4DF	5	kg
	mm	mm	mm	mm	mm	mm	mm	mm	mm	mm	mm	mm	mm	"	"	mm	kg
1 - 2 - 3 - 4 - 4M	774	226	498	51	458	163	263	187	335	99	486	208	198	1/2	1/2	16	22
5 - 6 - 6M	984	226	708	51	458	163	263	187	335	99	486	208	198	1/2	1/2	16	29
7 - 7M - 8 - 8M - 9 - 9M	1194	226	918	51	458	163	263	187	335	99	486	208	198	1/2	1/2	16	35
95	1194	251	918	48	497	185	259	195	348	120	478	234	208	3/4	1/2	16	36
10 - 10M - 11 - 11M	1404	251	1128	48	497	185	259	195	348	120	478	234	208	3/4	1/2	16	45
12	1614	251	1338	48	497	185	259	195	348	120	478	234	208	3/4	1/2	16	55

DIMENSIONAL DRAWINGS

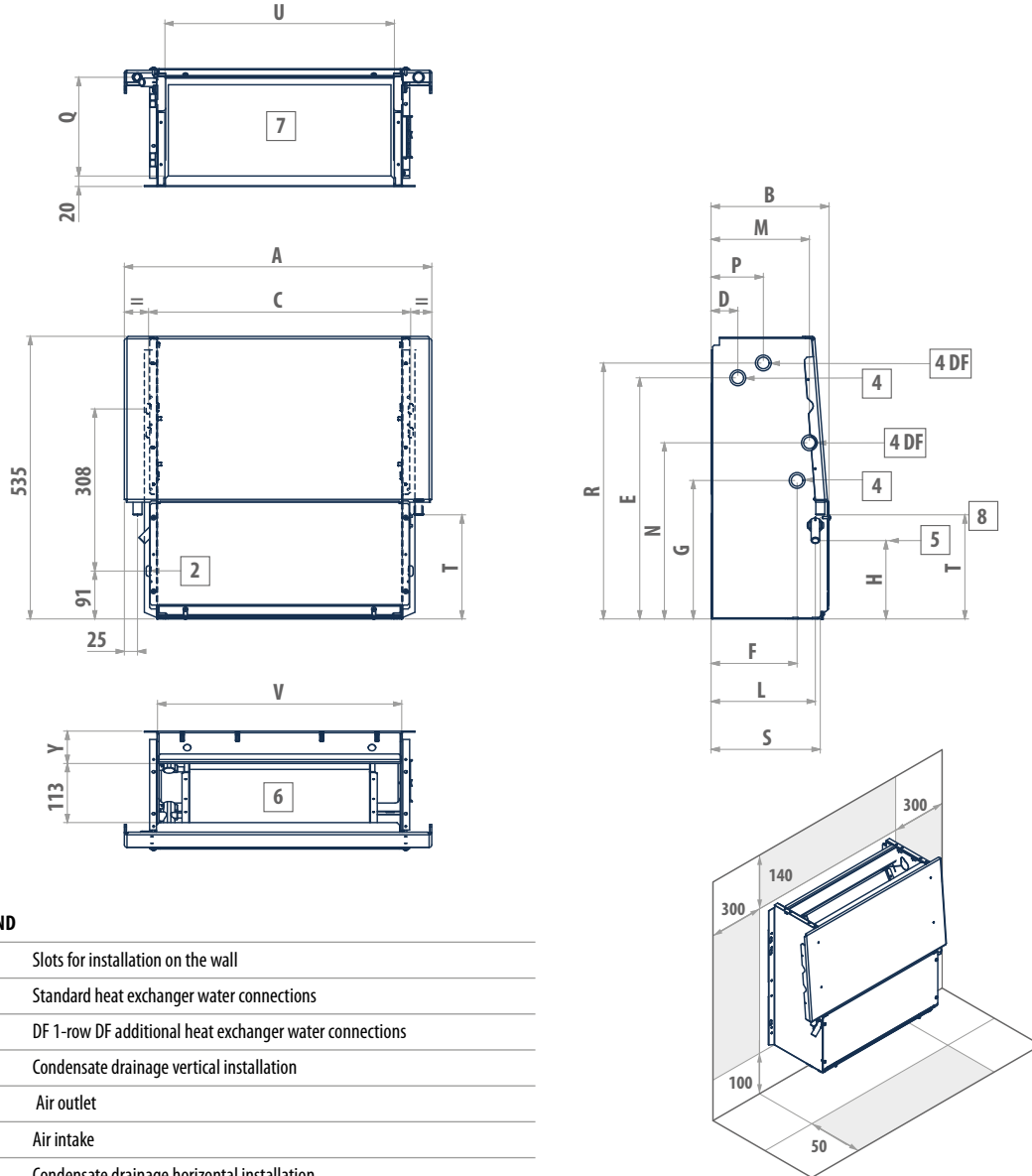
ESTRO FC

LEGEND

2	Slots for installation on the wall
4	Standard heat exchanger water connections
4DF	DF 1-row DF additional heat exchanger water connections
5	Condensate drainage vertical installation
6	Air outlet
7	Air intake
8	Condensate drainage horizontal installation

ESTRO FC	1	2	3	4	4M	5	6	6M	7	7M	8	8M	9	9M	95	10	10M	11	11M	12	
ON/OFF motor (3 speed)	x	x	x	x	x	x	x	x	x	x	x	x	x	x	x	x	x	x	x	x	x
ON/OFF motor (6 speed)	x	-	x	x	x	x	x	x	x	x	x	x	x	x	x	-	-	-	-	-	-
Inverter-controlled motor	x	-	x	x	x	x	x	x	x	-	x	-	x	x	x	-	-	x	x	x	x
GreenTech inverter-controlled motor	x	-	x	x	x	x	x	x	x	-	x	-	x	x	-	-	-	-	-	-	x

x = available

ESTRO	A	B	C	D	E	F	G	H	L	M	N	P	Q	R	S	T	U	V	Y	4	kg
	mm	mm	mm	mm	mm	mm	mm	mm	mm	mm	mm	mm	mm	mm	mm	mm	mm	mm	mm	"	
1 - 2 - 3 - 4 - 4M	584	224	498	51	458	163	263	149	198	187	335	99	189	486	208	198	436	464	61	1/2	18
5 - 6 - 6M	794	224	708	51	458	163	263	149	198	187	335	99	189	486	208	198	646	674	61	1/2	23
7 - 7M - 8 - 8M - 9 - 9M	1004	224	918	51	458	163	263	149	198	187	335	99	189	486	208	198	856	884	61	1/2	27
95	1004	249	918	48	497	185	259	155	220	195	348	120	215	478	234	208	856	884	67	3/4	27
10 - 10M - 11 - 11M	1214	249	1128	48	497	185	259	155	220	195	348	120	215	478	234	208	1066	1094	67	3/4	37
12	1424	249	1338	48	497	185	259	155	220	195	348	120	215	478	234	208	1276	1304	67	3/4	43

DIMENSIONAL DRAWINGS

ESTRO FF

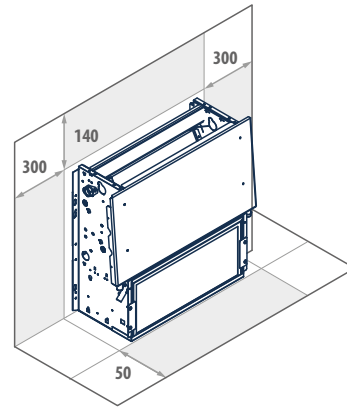
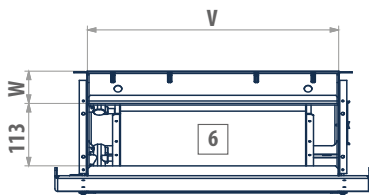
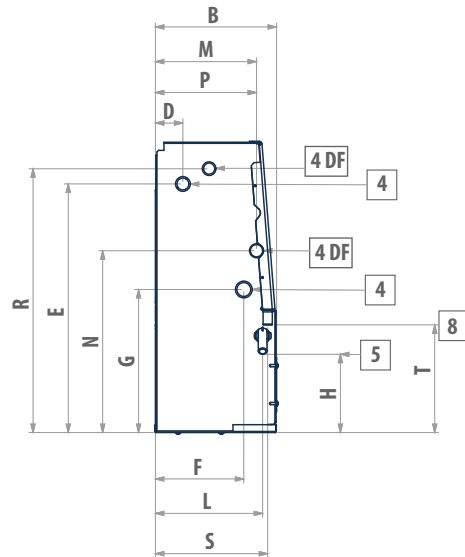
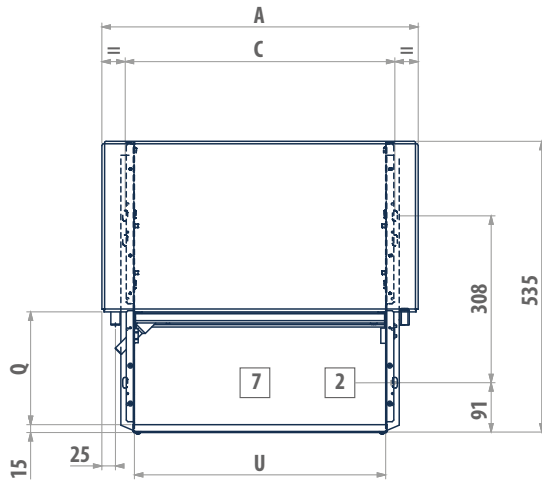

LEGEND

2	Slots for installation on the wall
4	Standard heat exchanger water connections
4DF	DF 1-row DF additional heat exchanger water connections
5	Condensate drainage vertical installation
6	Air outlet
7	Air intake
8	Condensate drainage horizontal installation

ESTRO FF	1	2	3	4	4M	5	6	6M	7	7M	8	8M	9	9M	95	10	10M	11	11M	12	
ON/OFF motor (3 speed)	x	x	x	x	x	x	x	x	x	x	x	x	x	x	x	x	x	x	x	x	x
ON/OFF motor (6 speed)	x	-	x	x	x	x	x	x	x	x	x	x	x	x	x	-	-	-	-	-	-
Inverter-controlled motor	x	-	x	x	x	x	x	x	x	-	x	-	x	x	-	-	-	x	x	-	-
GreenTech inverter-controlled motor	x	-	x	x	x	x	x	x	x	-	x	-	x	x	-	-	-	-	-	-	-

x = available

ESTRO	A	B	C	D	E	F	G	H	L	M	N	P	Q	R	S	T	U	V	W	4	kg
	mm	mm	mm	mm	mm	mm	mm	mm	mm	mm	mm	mm	mm	mm	mm	mm	mm	mm	mm	"	
1-2-3-4-4M	584	224	498	51	458	163	263	149	198	187	335	99	189	486	208	198	436	464	61	1/2	18
5-6-6M	794	224	708	51	458	163	263	149	198	187	335	99	189	486	208	198	646	674	61	1/2	23
7-7M-8-8M-9-9M	1004	224	918	51	458	163	263	149	198	187	335	99	189	486	208	198	856	884	61	1/2	27
95	1004	249	918	48	497	185	259	155	220	195	348	120	215	478	234	208	856	884	67	3/4	27
10-10M-11-11M	1214	249	1128	48	497	185	259	155	220	195	348	120	215	478	234	208	1066	1094	67	3/4	37
12	1424	249	1338	48	497	185	259	155	220	195	348	120	215	478	234	208	1276	1304	67	3/4	43

DIMENSIONAL DRAWINGS

ESTRO FB

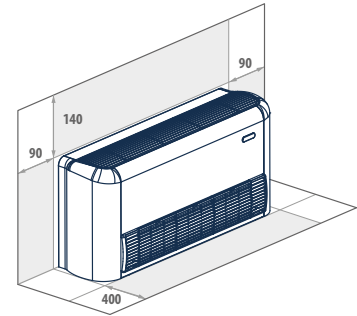
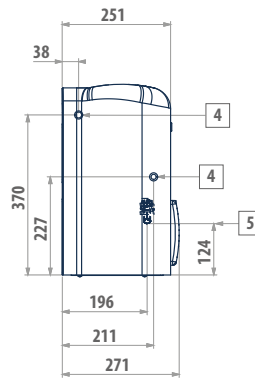
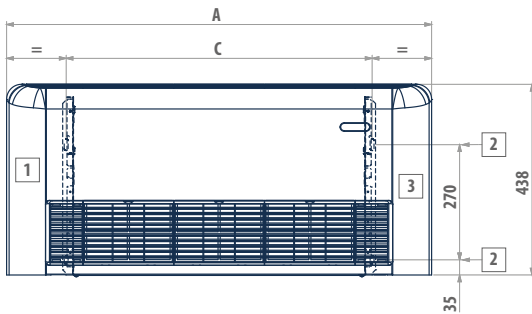
LEGEND

- | | |
|---|---|
| 1 | Usable space for plumbing connections |
| 2 | Slots for installation on the wall |
| 3 | Usable space for electrical connections |
| 4 | Standard heat exchanger water connections |
| 5 | Condensate drainage |

ESTRO FB	1	2	3	4	5	6	7	8	9
ON/OFF motor (3 speed)	x	x	x	x	x	x	x	x	x
ON/OFF motor (6 speed)	x	-	x	x	x	x	x	x	x
Inverter-controlled motor	x	-	x	x	x	x	x	x	x

x = available

ESTRO	A mm	C mm	4 "	5 mm	 kg
1 - 2 - 3 - 4	774	498	1/2	16	19
5 - 6	984	708	1/2	16	28
7 - 8 - 9	1194	918	1/2	16	29

ESTRO FBC

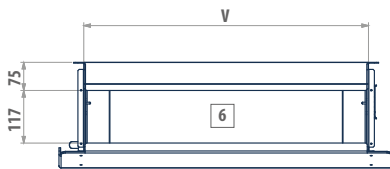
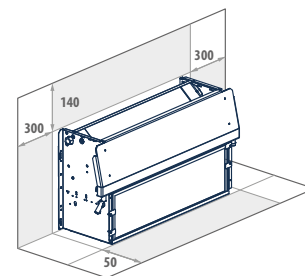
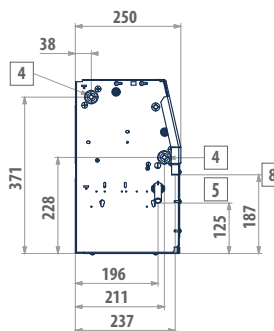
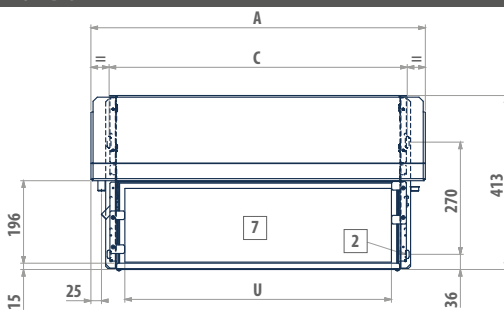
LEGEND

- | | |
|---|---|
| 2 | Slots for installation on the wall |
| 4 | Standard heat exchanger water connections |
| 5 | Condensate drainage vertical installation |
| 6 | Air outlet |
| 7 | Air intake |
| 8 | Condensate drainage horizontal installation |

ESTRO FBC	1	2	3	4	5	6	7	8	9
ON/OFF motor (3 speed)	x	x	x	x	x	x	x	x	x
ON/OFF motor (6 speed)	x	-	x	x	x	x	x	x	x
Inverter-controlled motor	x	-	x	x	x	x	x	x	x

x = available

ESTRO FBC	A mm	C mm	U mm	V mm	4 "	5 mm	 kg	 kg
1	584	498	423	464	1/2	16	14.5	16
2 - 3 - 4	584	498	423	464	1/2	16	15.5	16
5	794	708	633	674	1/2	16	19	20
6	794	708	633	674	1/2	16	20	20
7 - 8	1004	918	843	884	1/2	16	24	25
9	1004	918	843	884	1/2	16	24.5	25