



DUCT AND ROOM AIR QUALITY TRANSMITTERS, VOC

DB-xLQ

FUNCTION

Analysis of the air quality based on a mixed gas VOC (Volatile Organic Compounds) sensor for:

- measuring the air quality inside offices, hotels, meeting rooms, homes, shops, restaurants and so on;
- quantitative analysis of the contamination of room air, caused by polluting gases;
- setting of the sensitivity threshold according to the maximum air contamination expected;
- ventilation of premises only when necessary, to allow energy saving.

APPLICATIONS

Well-suited for ventilation and air treatment systems in domestic areas and commercial buildings.

TYPE	OUTPUT	APPLICATION
DB-RLQ	0...10 Vdc, 0...20 mA, 4...20 mA	room
DB-RLQ5	0...5 Vdc, 0...20 mA, 4...20 mA	room
DB-KLQ	0...10 Vdc, 0...20 mA, 4...20 mA	duct
DB-KLQ5	0...5 Vdc, 0...20 mA, 4...20 mA	duct

TECHNICAL DATA

Power supply:	15...36 Vdc or 24 Vac/dc \pm 10%, 50-60 Hz
Outputs:	0...10 Vdc, 0...20 mA or 4...20 mA, selectable by jumpers (RLQ version) or dip-switch (KLQ version)
Sensor:	VOC
Working:	0...+50 °C
	10...95% r.h. (without condensing)
Storage:	-20...+50 °C
	< 95% r.h.
Housing:	RLQ: plastic material similar to RAL 9010 KLQ: plastic material similar to RAL 9010 aluminum tube
Protection:	RLQ: IP30, class III KLQ: IP65 (housing), class III
Size:	RLQ: 75 x 75 x 25 mm KLQ: 65 x 59 x 36 mm (tube L = 206 mm, diameter = 16 mm)
Weight:	RLQ: 80 g KLQ: 260 g
CE standards:	EN 60335-1: safety EN 60529: IP degree of protection EN 60730: domestic controls

Detectable gases:

- carbon monoxide CO
- Hydrogen sulfide H₂S
- solvent vapours
- alkane vapours
- cigarette smoke
- car exhaust
- air produced by human breathing
- combustion smoke from wood, paper and plastics

Warnings:

The air quality monitoring sensor cannot be used for purposes of safety.

WIRING DIAGRAM/ DIMENSIONS

DB-RLQ

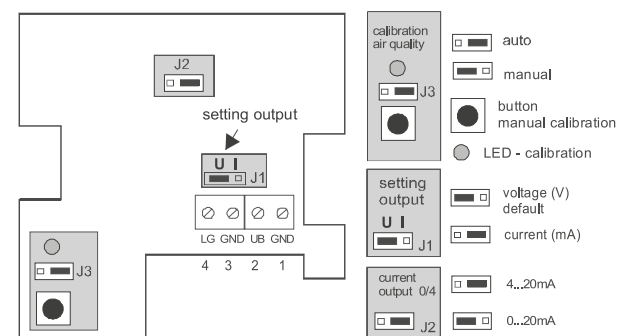

Power supply	AC	DC
→ 1	0V	GND
→ 2	24V~	15...36V DC
output		
3 →	GND / 0V	GND
4 → (LQ)	0...10V	0...10V

ground (1) and (3) are electrically connected on the PCB

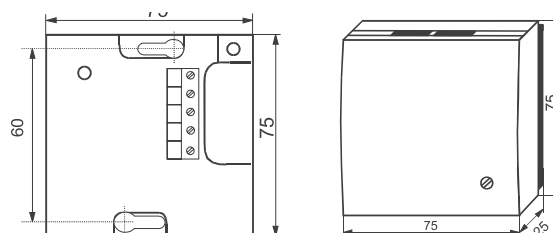

DB-KLQ

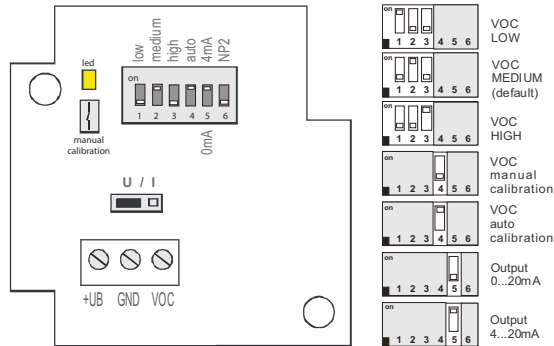

Power supply	AC	DC
→ 1 (+UB)	24V~	15...36V DC
→ 2 (GND)	0V	GND
Output	DC	DC
3 → (VOC)	0...10V	0...10V

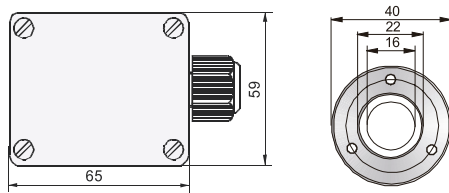
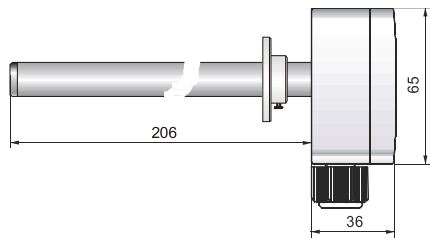

Measurement and calibration of air quality by customer

The lifetime of the sensors is limited based on how it is used, particularly the type and concentration of gas. The measurement of air quality detects the general condition of air. The 0...10 Vdc output signal depends on different gases, for instance cigarette smoke, deodorant sprays, detergents, adhesives etc.

The apparatus is made and calibrated for use in rooms where gas-phase stripping has finished. The zero point and the measurement range are factory set by using synthetic air and a fixed amount of hydrogen respectively. The standard use of the unit is the detection of changes of the air quality related to the fixed zero point.

There can be an overstep of the measurement range or an overload of the sensor in some cases (new carpets, fresh paint etc.). The customer himself has to calibrate the unit according to the circumstances of use in those cases.

Automatic self-calibration of air quality:

RLQ J3 in auto position, KLQ dip-switch 4 in auto position. The measurement value of air quality is saved for 4 weeks. After that time the minimum of the saved values is set to zero point (output 1,0 Vdc). The maximum correction is limited to 1 Vdc at each interval of four weeks. Long term drift and aging effects of the sensor element are eliminated almost completely. The autocalibration only works if fresh air is supplied to the sensor at least one time within four weeks.

Manual calibration of air quality

The manual calibration can be started by pressing the button "manual calibration" regardless of jumper J3 or dip-switch 4. The instrument should operate for at least 2 hours at "normal air" before starting the manual calibration. Press the button "manual calibration" for about 5 sec until the LED starts flashing. Now the output is automatically set to 1 Vdc at the actual environmental conditions. During that process the LED is on. After finishing the calibration successfully, the LED will be light off. The automatic self-calibration is deactivated if jumper J3 or dip-switch 4 is in position "manual".

Starting operation

After power is switched on a self-test is performed and the unit is preheated. During that phase, for about 60 minutes, the measurement value is not correct.

INSTALLATION

To protect the unit against reverse polarity, a protection diode is used. This allows the transmitter to be used with 24 Vac power supply. The output signal must be measured with a suitable instrument and referenced to GND terminal. If the instrument is operated in direct current power supply, connect the 15...36 Vdc input to the UB terminal and the ground to the GND terminal.

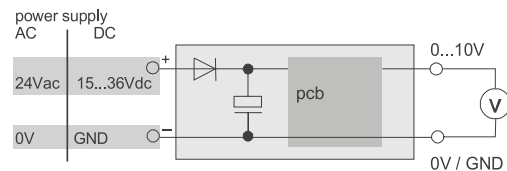

If several instruments are supplied with 24 Vac power supply, all inputs have to be connected to the same phase. Otherwise all instruments could be damaged. All outputs have to be measured referenced to the same potential (see figure below).

