

[19830]



Category: Automation systems



Digital output module

with manual / emergency operating function for DIN rail mounting
2 x 3 digital outputs, 230 V AC/ 6A potential-free

DIGICONTROL ems 4.DA04H

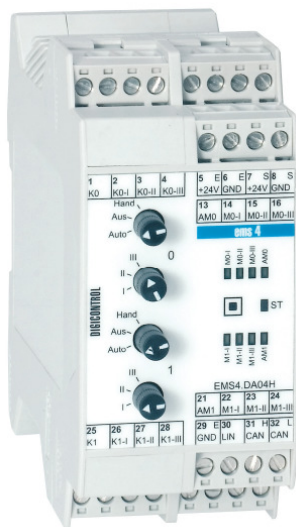

Application

ems 4 - output modules with manual / emergency operating function

combine electrical outputs with an integrated manual / emergency operation function. They are designed for installation in the control cabinet (DIN rail).

General technical features:

- Additional emergency voltage 24 VDC, $\pm 10\%$
- Control via internal CAN bus and internal manual / emergency operating elements on the module itself
- The manual / emergency function remains active even without standard supply voltage 24 V or without microprocessor and CAN system bus

The ems 4.DA04H is a module for switching 2 x 3-stage relay outputs with an additional manual / emergency operating function and it is equipped with an integrated microcontroller and memory module for accommodating a specially coordinated programme.

The module software allows all signals to be processed in the automatic and manual mode. Additional functions (e.g. processing fault signal inputs and command run control) are also implemented by the module software.

Technical features:

- 6 digital outputs, 2 x 3-stage, relays internally connected
- Relay switching current 230 VAC, 6 A ohmic load
- Manual operation via rotary switch per output (LEVEL3-LEVEL2-LEVEL1 and OFF-AUTO-MANUAL)
- 5 digital inputs (24 VDC) for feedback connection (2x LEVEL 1, LEVEL 2, LEVEL 3)
- Feedback either via the digital input or direct use of the output signal (jumper)
- 2 digital fault signal inputs (24 VDC)
- Programmable command run control
- LED (green) status indicator for the outputs
- (Output signal or signal input (jumper setting))
- LED (red) status indicator of the fault signal inputs

Article number: EMS4.DA04H

Specifications

Number of outputs	6 relay digital outputs, 2 x 3-stage, relays internally connected
Status indicator for the outputs	1 x LED per output
Output signal	Relay up to 230V, potential-free contact (NO contact) Switching capacity 6 A ohmic
Inputs	8 inputs (24 V DC) - also refer to the technical features Short-term pulse from 20 mS
Dimensions	45 x 100 x 115 mm
Connecting terminals	via screw terminals for wires up to 2.5mm ²
EMC electromagnetic interference	EN 61000-6-4, EN 50081, (EN55022)
EMC interference immunity	EN 61000-6-2, EN 50082, (EN55024)
EMC burst	EN 61000-4-4
Housing	Plastic housing
Weight	270 g
Manual operation	via rotary switch per output (LEVEL3-LEVEL2-LEVEL1 and OFF-AUTO-MANUAL)
DIN rail bus connector CAN / LIN	max. 30 mating cycles, contact load 1A
Storage temperature	-10...+70 °C



Power consumption	2 W power consumption during functional operation, 4 W with CAN bus activity
Humidity	up to 85% without condensation according to VDE 0160, EN 50178, Class 3K3
Installation positions	On vertical surfaces (wall mounting, terminals at top and bottom)
Standards	EN 50178 - Electronic equipment for use in power installations
Interfaces	1 x LIN
Protection type	IP 20
Service button	on device front
Power supply	24 V DC $\pm 10\%$
Module status display	via Duo-LED
System bus	CAN
Ambient temperature during operation	+5...+40°C

Module configuration, connection

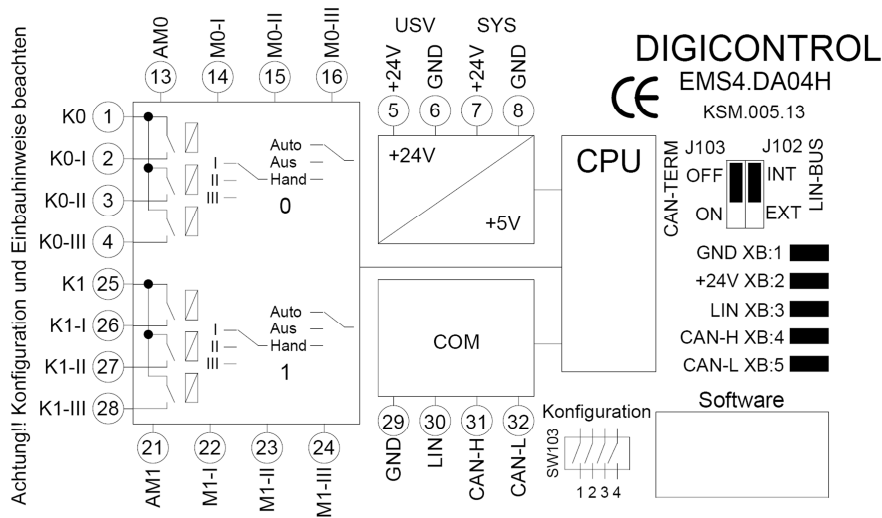

Dimensions

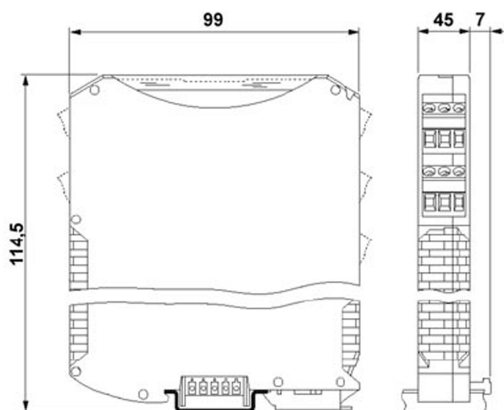

Position of the jumpers / DIP switches

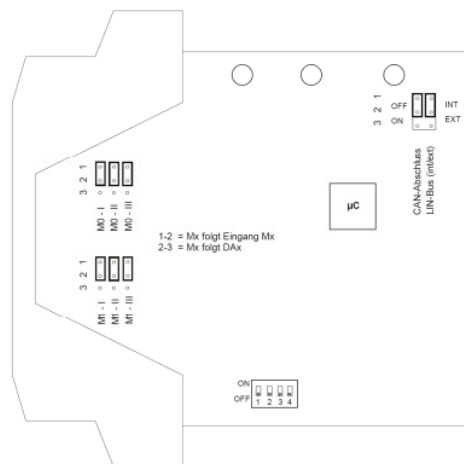

Configuration of position feedback: If a feedback signal is connected to the module, the jumper is to be configured for a feedback signal accordingly.



ems 4 - Module configuration

Each ems 4 module is assigned an individual module address by the webCADpro configuration tool.

By default the address for all modules is 0.

There are two ways of programming the address for the ems 4 modules.

This can be conducted by using:

1. The service button on the ems 4 modules
2. The serial number (programmed when the module is manufactured)

A detailed description can be found in the operating manual.

ems 4 - Installation instructions

- Also observe the installation instructions in the operating manual!
- The modules should never be dismantled when they are energised or installed in live systems!
- Subject to technical alterations

ems 4 - Module version identification

The type plate, which includes the device's serial number, can be found on the front right-hand side of the ems 4 modules. The serial number is programmed when the module is manufactured. It can be used, for example, to programme the module address via the control unit (see the Configuration Tool section). The serial number and software version can also be read via the webCADpro configuration tool (see the MultiLink Manager section).

ems 4 - General module data

- Module widths (DIN rail mounting) in a 22.5 mm x n grid
- Standard: 22.5 mm, 45.0 mm, 67.5 mm, 90.0 mm
- Connection voltage: 24 VDC, $\pm 10\%$, must be connected separately every 10 modules
- Connection terminals pluggable up to 2.5mm²
- CAN system bus on 5-pin bus connector
- CAN bus connector can be mounted in a DIN rail module
- Bus terminal 1, 0 VDC system voltage
- Bus terminal 2, +24 VDC system voltage
- Bus terminal 3, LIN sub bus
- Bus terminal 4, CAN H signal
- Bus terminal 5, CAN L signal
- DUO LED for status display
- 4-pin DIP switch for CAN transfer speed
- Maximum 62 bus modules can be connected to the system bus (CAN) without a repeater
- Type information and connection diagram printed on the side
- Front plates: White background, black / blue inscription
- The housing colour is light grey (similar to RAL 7035)
- Each module has additional space (15 mm x 9 mm) for an equipment identification label

GFR - Gesellschaft für Regelungstechnik
und Energieeinsparung mbH

Kapellenweg 42
D-33415 **Verl**
phone: +49 (0) 5246 962-0
www.gfr.de / info.verl@gfr.de

Löbstedter Str. 101
D-07749 **Jena**
phone: +49 (0) 3641 4697-0
info.jena@gfr.de

01.2009 / Rev4

