

[19410]



Category: Automation systems



Analogue input module

DIN rail mounting

8 analogue inputs, 0(2) ..10 V DC, 10 Bit

DIGICONTROL ems 4.AE01B



Article number: EMS4.AE01B

Application

The ems 4.AE01B is a module for recording analogue input signals 0(2)..10 V DC, 10 Bit with an integrated microcontroller and memory module for accommodating a specially coordinated programme.

The transmission frequency of the module and attenuation of the input signal can be parameterised via one hysteresis value and one filter constant per input. A further parameter per input enables the selection between a 0...10 VDC and a 2...10 VDC input.

Specifications

Number of inputs	8
Resolution	10 Bit
Input signal	0(2)..10 V DC
Dimensions	22.5 x 100 x 115 mm
Connecting terminals	via screw terminals for wires up to 2.5mm ²
EMC electromagnetic interference	EN 61000-6-4, EN 50081, (EN55022)
EMC interference immunity	EN 61000-6-2, EN 50082, (EN55024)
EMC burst	EN 61000-4-4
Housing	Plastic housing
Weight	130 g
DIN rail bus connector CAN / LIN	max. 30 mating cycles, contact load 1A
Storage temperature	-10...+70 °C
Power consumption	2 W power consumption during functional operation, 4 W with CAN bus activity
Humidity	up to 85% without condensation according to VDE 0160, EN 50178, Class 3K3
Installation positions	On vertical surfaces (wall mounting, terminals at top and bottom)
Interfaces	1 x LIN
Protection type	IP 20
Service button	on device front
Power supply	24 VDC ±10 %
Module status display	via Duo-LED
System bus	CAN
Ambient temperature during operation	+5...+40°C



Module configuration, connection

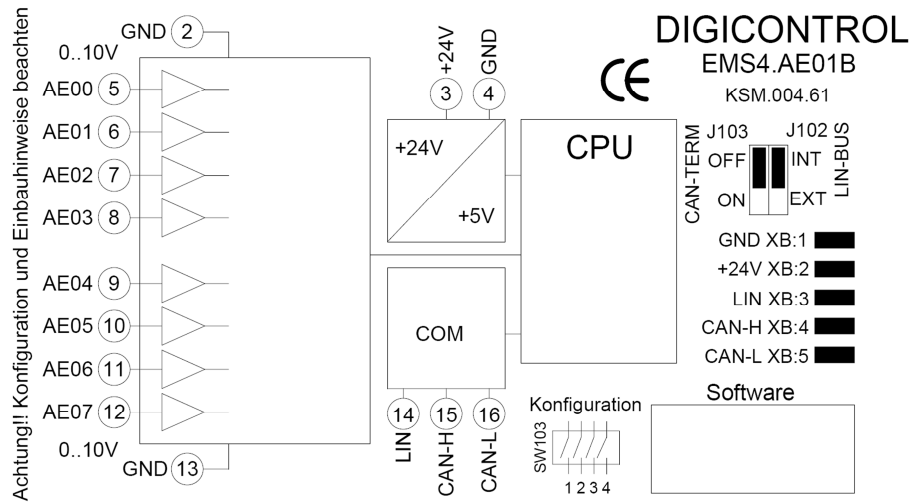

Dimensions

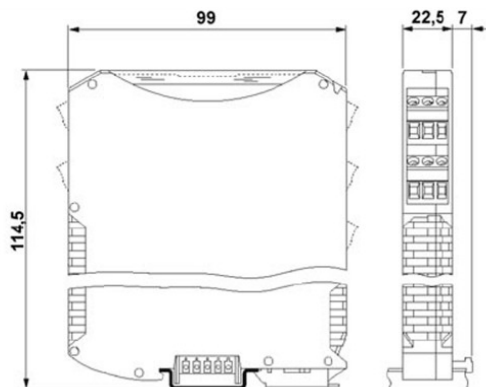

Position of the jumpers / DIP switches

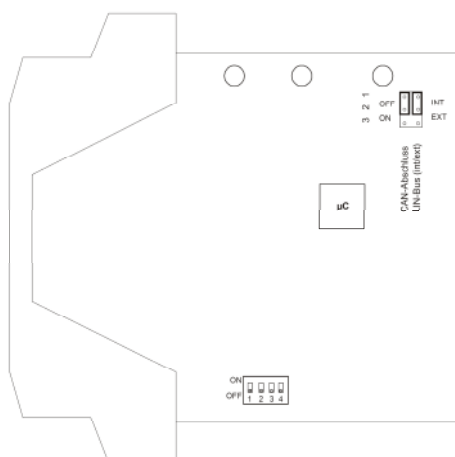



ems 4 - Module configuration

Each ems 4 module is assigned an individual module address by the webCADpro configuration tool.

By default the address for all modules is 0.

There are two ways of programming the address for the ems 4 modules.

This can be conducted by using:

1. The service button on the ems 4 modules
2. The serial number (programmed when the module is manufactured)

A detailed description can be found in the operating manual.

ems 4 - Installation instructions

- Also observe the installation instructions in the operating manual!
- The modules should never be dismantled when they are energised or installed in live systems!
- Subject to technical alterations

ems 4 - Module version identification

The type plate, which includes the device's serial number, can be found on the front right-hand side of the ems 4 modules. The serial number is programmed when the module is manufactured. It can be used, for example, to programme the module address via the control unit (see the Configuration Tool section). The serial number and software version can also be viewed via the webCADpro configuration tool (see the MultiLink Manager section).

ems 4 - General module data

- Module widths (DIN rail mounting) in a 22.5 mm x n grid
- Standard: 22.5 mm, 45.0 mm, 67.5 mm, 90.0 mm
- Connection voltage: 24 VDC, $\pm 10\%$, must be connected separately every 10 modules
- Connection terminals pluggable up to 2.5mm²
- CAN system bus on 5-pin bus connector
- CAN bus connector can be mounted in a DIN rail module
- Bus terminal 1, 0 VDC system voltage
- Bus terminal 2, +24 VDC system voltage
- Bus terminal 3, LIN sub bus
- Bus terminal 4, CAN H signal
- Bus terminal 5, CAN L signal
- DUO LED for status display
- 4-pin DIP switch for CAN transfer speed
- Maximum 62 bus modules can be connected to the system bus (CAN) without a repeater
- Type information and connection diagram printed on the side
- Front plates: White background, black / blue inscription
- The housing colour is light grey (similar to RAL 7035)
- Each module has additional space (15 mm x 9 mm) for an equipment identification label

GFR - Gesellschaft für Regelungstechnik
und Energieeinsparung mbH

Kapellenweg 42
D-33415 **Verl**
phone: +49 (0) 5246 962-0
www.gfr.de / info.verl@gfr.de

Löbstedter Str. 101
D-07749 **Jena**
phone: +49 (0) 3641 4697-0
info.jena@gfr.de

01.2009 / Rev4

